

TB0415 Method to Prevent Loosening of Saw Blade

Method to Prevent Loosening of Saw Blade

 Difficulty **Medium**

 Duration **30 minute(s)**

Contents

Introduction

Problem

Solution

Tool List

Parts List

Items

Step 1 - Remove bolt, washer, blade and blade flanges

Step 2 - Fit Spindle Stud

Step 3 - Drill Ø5 hole through shaft and stud for roll pin

Step 4 - Insert roll pin to lock stud in position

Step 5 - Re-fit blade and blade flanges

Step 6 - Fit Washer

Step 7 - Fit Castle Nut

Step 8 - Install Cotter Pin

Comments

Introduction

Problem

On Z063 the bolt holding the saw blade onto the spindle has regularly been loosening during use.

Solution

The M16 bolt will be replaced with a stud and castle nut that can be locked with a cotter pin.

Tool List

Drill with Ø5.0 bit

24mm Spanner

C Spanner

Parts List

D0004031B	Saw Washer 3mm	1
D0015560	Spindle Stud	1
F0000273	Spirol Pin Ø6 x 30	1
F0000549	Split Pin 4mm x 32	1

Items

🛒 Spanner 24mm

Step 1 - Remove bolt, washer, blade and blade flanges

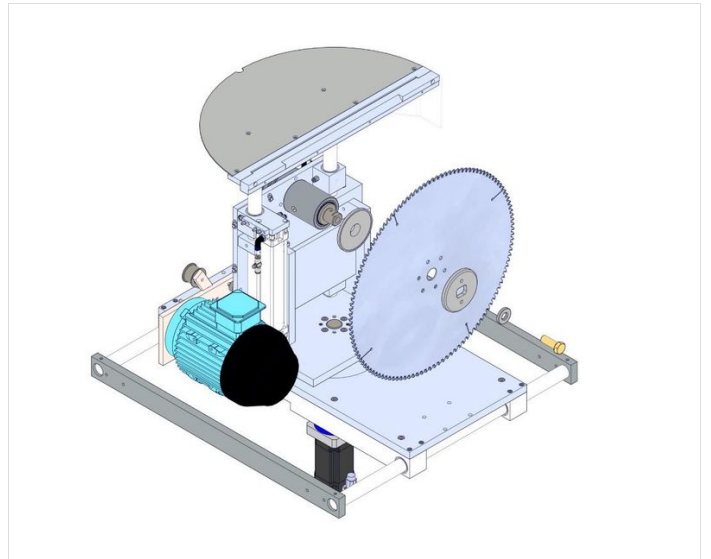

Step 2 - Fit Spindle Stud

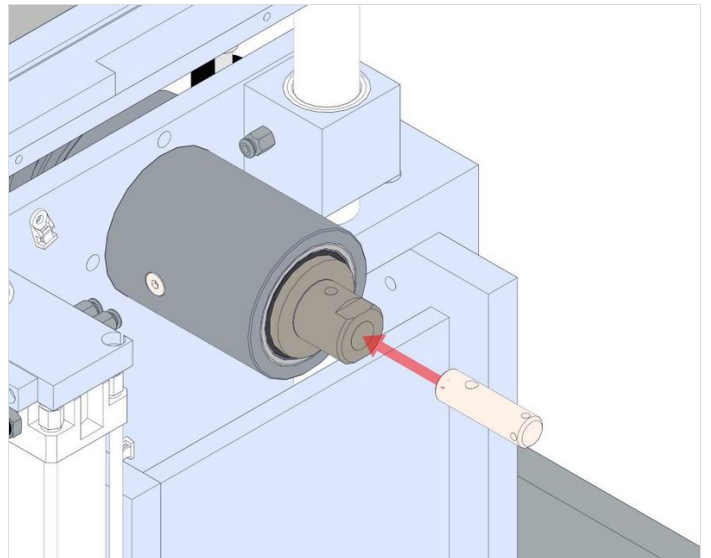

Step 3 - Drill $\text{\O}5$ hole through shaft and stud for roll pin

Position on shaft not important.

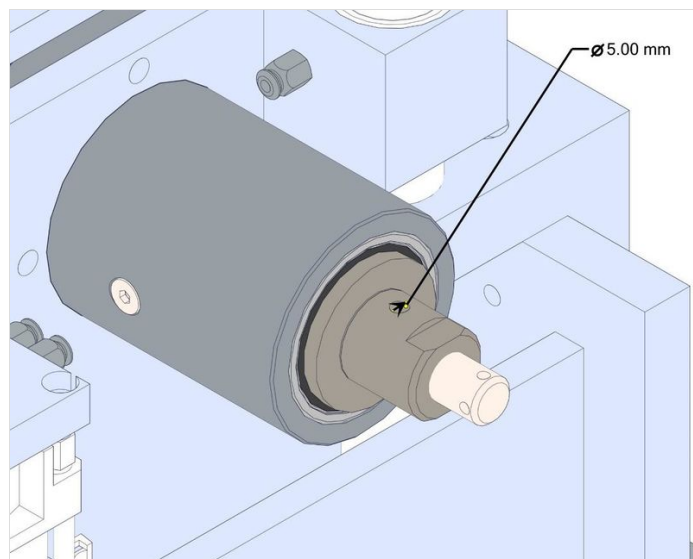

Step 4 - Insert roll pin to lock stud in position

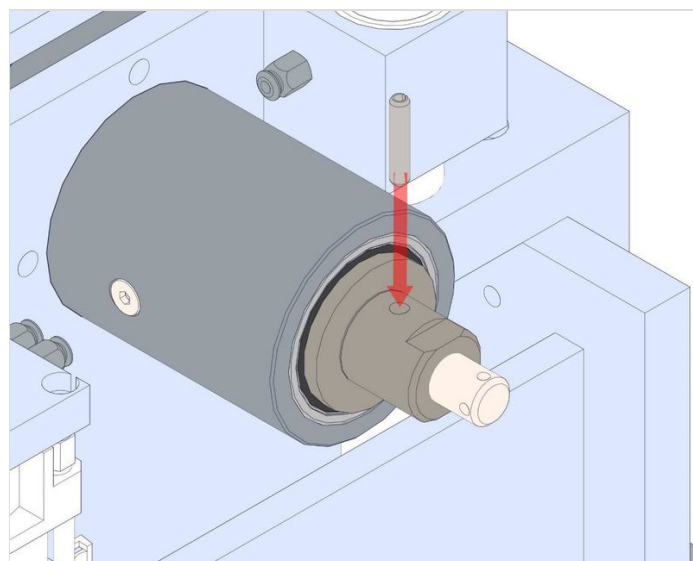

Step 5 - Re-fit blade and blade flanges

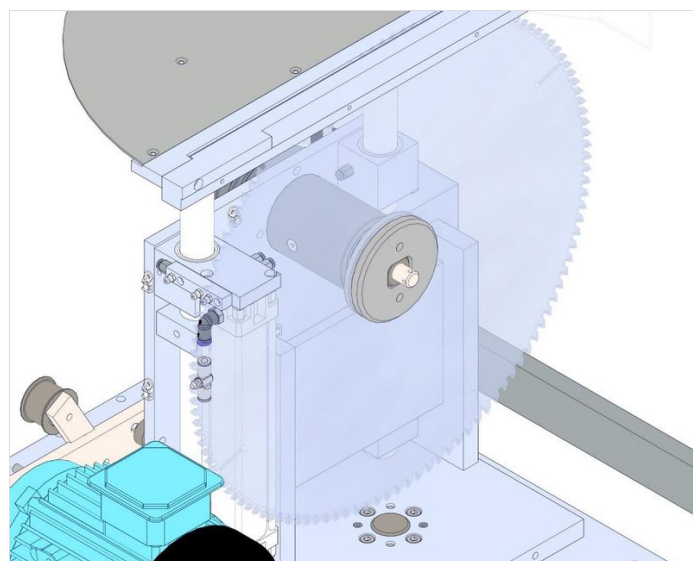

Step 6 - Fit Washer

Align flats on washer to ensure holes for pin spanner are clear.

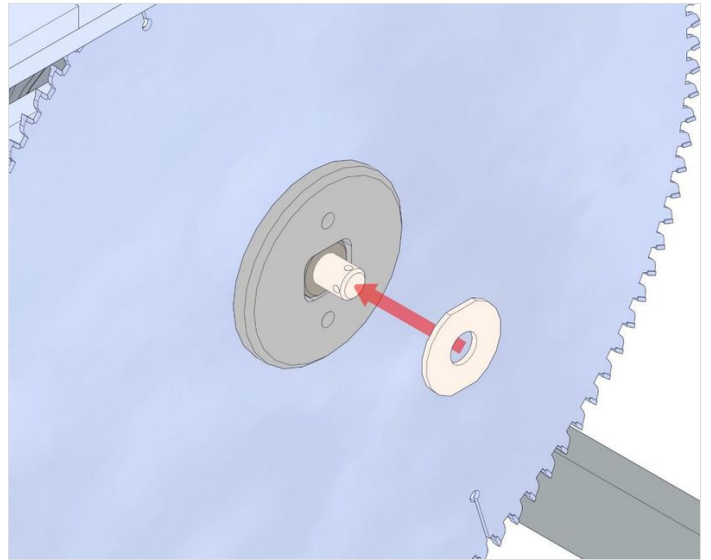

Step 7 - Fit Castle Nut

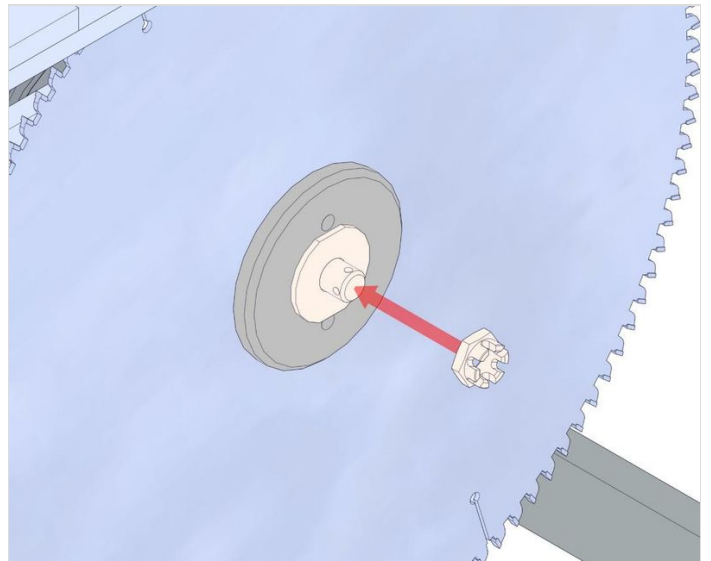

Step 8 - Install Cotter Pin

Ensure pin is secure and cannot be dislodged during normal operation.

