

TB0315 Fitting Autoflow Dark Profile Sensor

Dark windows profiles were sometimes not picked up by the photoelectric sensors, resulting in incorrect length measurements, and errors on the machine.

Contents

Technical Bulletin

Problem

Solution

Required Parts

Comments

Technical Bulletin

TB Number:	315
Originator:	Max Hamlet
Machine:	Autoflow
Date:	11/08/16
Circulate to:	Stuga Service Engineers
Title:	Fitting Autoflow Dark Profile Sensor

Problem

Dark windows profiles were sometimes not picked up by the photoelectric sensors, resulting in incorrect length measurements, and errors on the machine.

Solution

The installation of a new sensor and bracket overcomes this issue. The new sensor detects dark profiles much more reliably. The bracket uses the same mounting bolts as the old set up.

Required Parts

Part Number	Description	Quantity
D0010878	Bracket Base: Laser Sensor	1
D0010879	Bracket Mount: Laser Sensor	2
E0001064	Connector: Field Attachable, M8 3 wire, Male IDC	1
E0001175	Sensor: Laser Distance 300mm M12 5 Pin	1
E0001179	Connector M12 5 wire female straight PVC 1m	1
F0000006	M5 x 10 Caphead Screw S/S	4

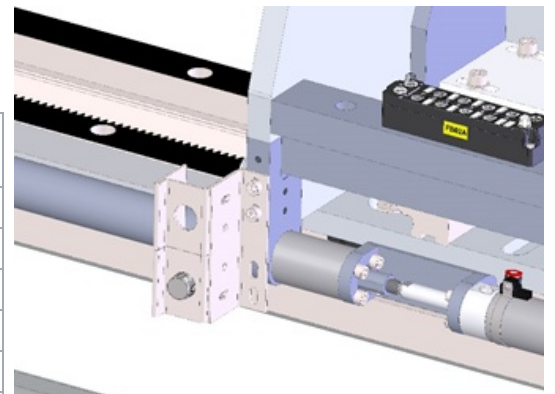

Fit the sensor and bracket shown in the 2 images. The cable should run out of the top of the brackets, which gives protection to the cable plug. Connection is then made to the etherCAT box as per the previous sensor.

