

# Saw machining centre alignment and level check points

Key points for alignment check

 Difficulty **Hard**

 Duration **1 hour(s)**

## Contents

Introduction

Step 1 - Clean surfaces

Step 2 - Turntable level

Step 3 - Cylinder base level

Step 4 - Eject shaft level

Step 5 - Eject support level

Step 6 - Eject support level

Step 7 - Cut table level

Step 8 - Eject table level

Comments

## Introduction

Bullet pointed checks to determine correct alignment of key components within Sawing unit

### Step 1 - Clean surfaces

Ensure all faces being checked are clean and free from dust and swarf .

Accuracy of level reading is vital in this operation



## Step 2 - Turntable level

check level in the 2 indicated areas

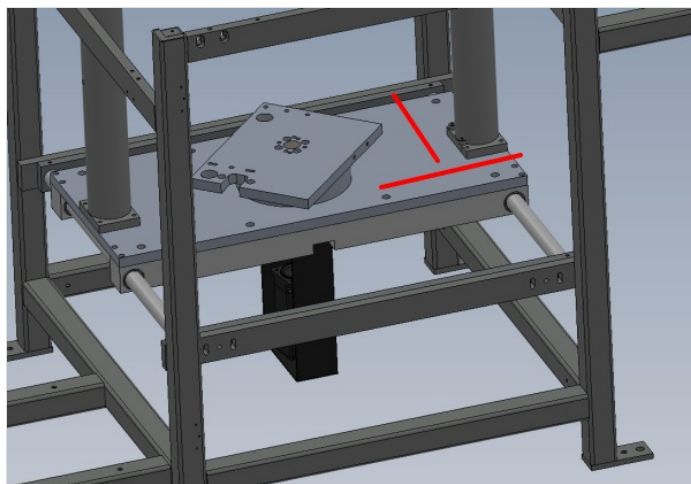

## Step 3 - Cylinder base level

check level in the indicated area

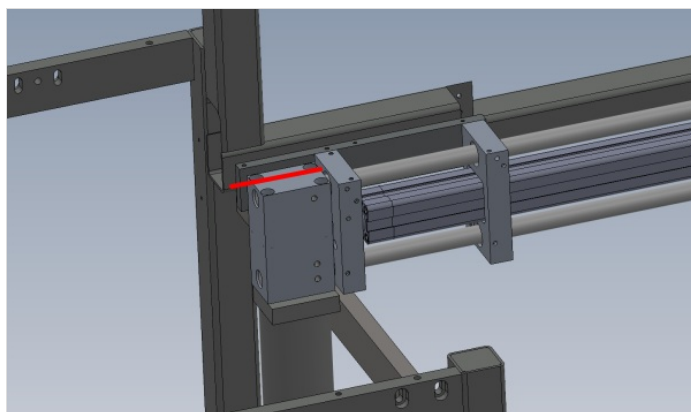

## Step 4 - Eject shaft level

check level in the indicated areas

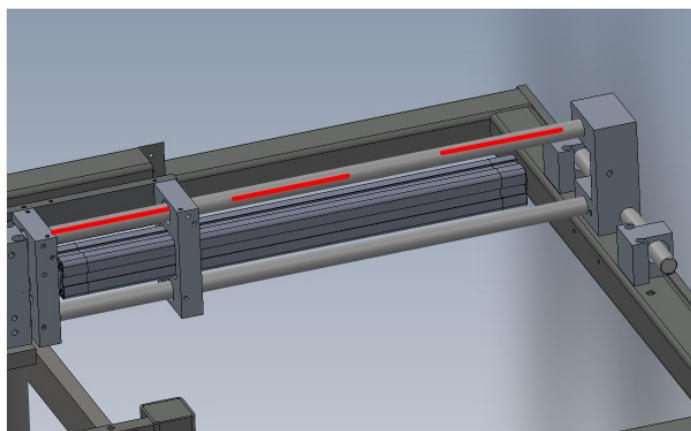

## Step 5 - Eject support level

check level in the indicated area

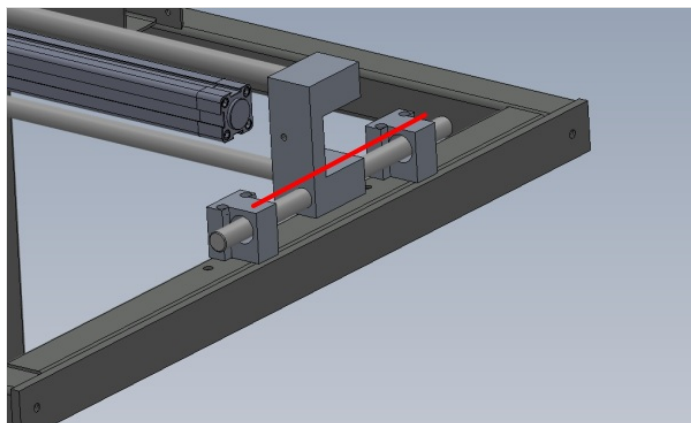

## Step 6 - Eject support level

check level in the indicated area

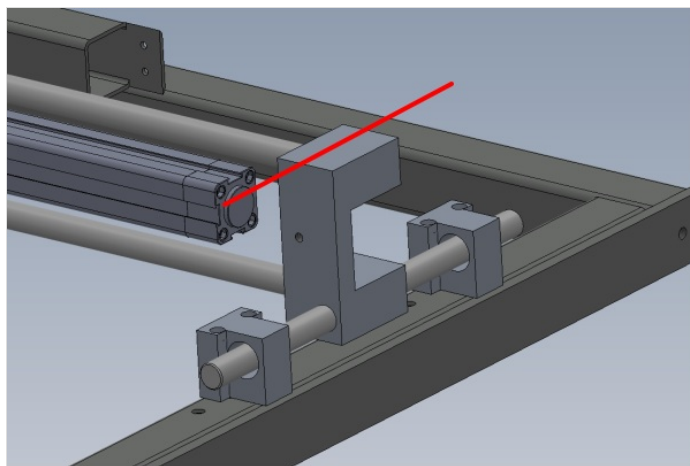

---

## Step 7 - Cut table level

check level in the indicated areas

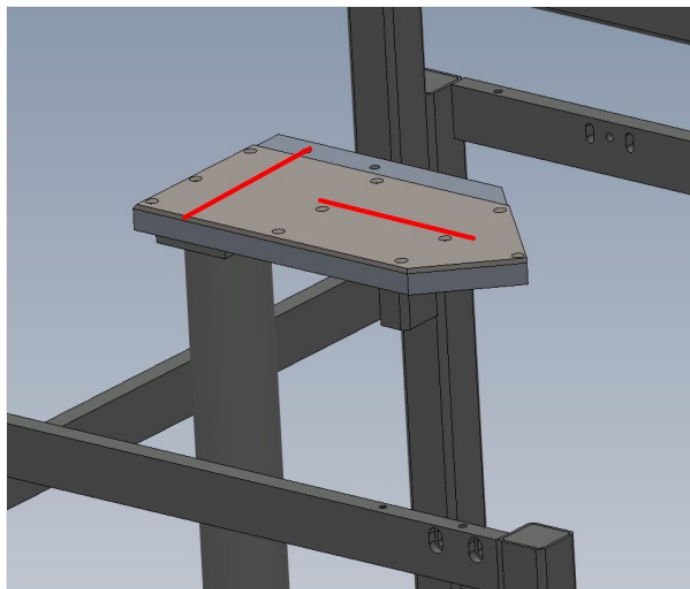

---

## Step 8 - Eject table level

check level in the indicated areas

