

RMZX501 ZX5 Remove Chain and Sprocket Hazard

Replace infeed flights

Contents

Hazard Identification and Risk Assessment

Work to be completed

Comments

Hazard Identification and Risk Assessment

Hazard Rating and risk assessment - Before Modification

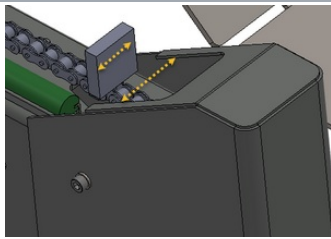
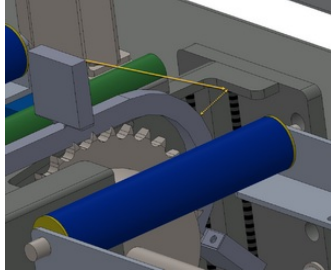
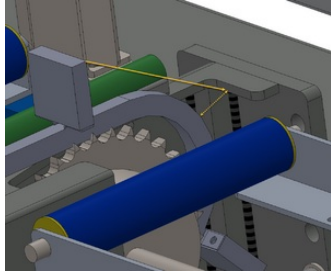
Hazard	Picture	LO	DPH	FE	NP	PHR	Rating
Finger trap infeed flight to front cover plate, when chain system is in reverse		Unlikely	Break Minor Bone	Daily	16-50	60	High
Finger trap infeed flight to front cover plate Infeed Light curtain not fitted		Unlikely	Break Minor Bone	Daily	16-50	60	High
Finger trap infeed flight to front cover plate Infeed Light curtain fitted		Impossible	Break Minor Bone	Daily	16-50	0	Zero

For explanation of column headings and risk rating system see Hazard Rating System Hazard

Work to be completed

- Replace infeed chains and flights to narrow the flight width and remove the sharp edges of the flight upstands, by rotating through 90 degrees to vertical orientation
- Replace 9 off chains, each with 17 off flights
- Estimated fitting Time - 4 hours

Pictures

Original Flight	Replacement flight
-----------------	--------------------

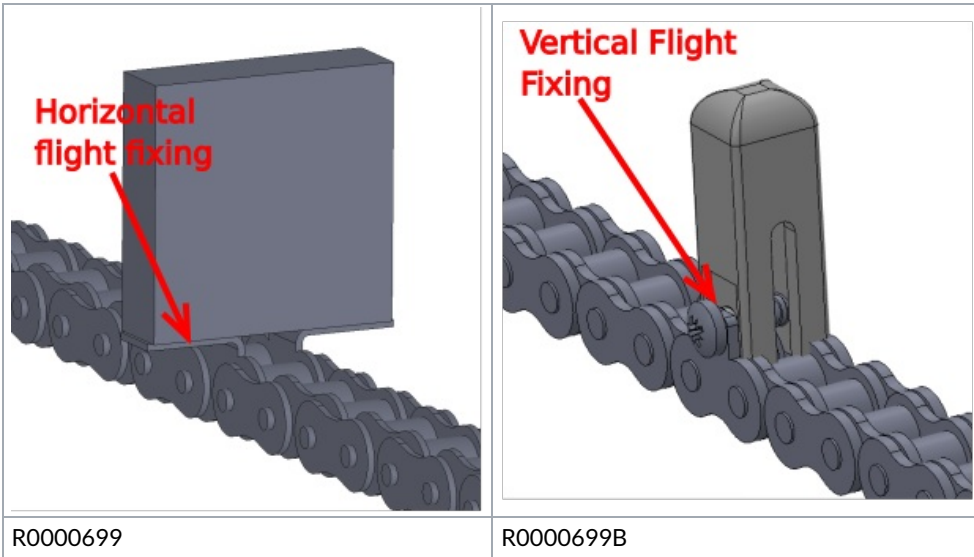

Hazard Rating and risk assessment - After Modification

Hazard	LO	DPH	FE	NP	PHR	Rating
Finger trap infeed flight to front infeed cover plate, chain reversing	Unlikely	Scratch or Bruise	Daily	16-50	1.5	Very Low

- Same HRN applies to entire infeed hazard when light beam is fitted