

# R0015335 Mount Electrical Cabinet

Details for mounting of electrical control panel

 Difficulty **Medium**

 Duration **1 hour(s)**

## Contents

Introduction

Step 1 - Unless otherwise stated

Step 2 - Fit Trunking 1

Step 3 - Cut Trunking 2

Step 4 - Fit Air gun bracket

Step 5 - Fit side sheet

Step 6 - Fit trunking to side sheet

Step 7 - Fit ethercat mount plate

Step 8 - Fit Regulator bracket

Step 9 - Assemble air gun regulator

Step 10 - Assemble air gun assembly

Step 11 - Connect pipe

Step 12 - Position Cabinet

Step 13 - Fix cabinet

Comments

## Introduction

### Tools Required

Standard hex key set

Standard spanner set

Standard HSS drill set

Standard Tap set

### Parts Required

D0004391E Left hand side sheet x 1 D0015425 Bracket: Beckhoff Box Right Angle x 1

D0015426 Mounting Plate: Airgun Assy x 1

D0015425 Beckhoff right angle mounting plate x 1

P0000020 Fitting: Plug 1/8" BSP (Grubscrew Type) x 1

P0000021 Airgun Assembly x 1

P0000142 Elbow Adaptor 8mm - 1/8 BSP x 2

P0000277 Fitting: Bulkhead Female 8mm x 1/4 BSP x 1

P0000278 Regulator 0-2 bar x 1

P0000373 Regulator fixing bracket x 1

R0015016C Electrical cabinet wiring Mod F

## Step 1 - Unless otherwise stated

All bolts to have Loctite 243 adhesive applied unless otherwise stated

All Threaded Pneumatic connections to have Loctite 570 applied

All bolts to be pen marked once adhesive applied and correct tension added



---

## Step 2 - Fit Trunking 1

1 Fit 1 length of trunking as shown. Fix with M5 x 10 button sockets and penny washers

Remove sections shown to align with cutout on side sheet

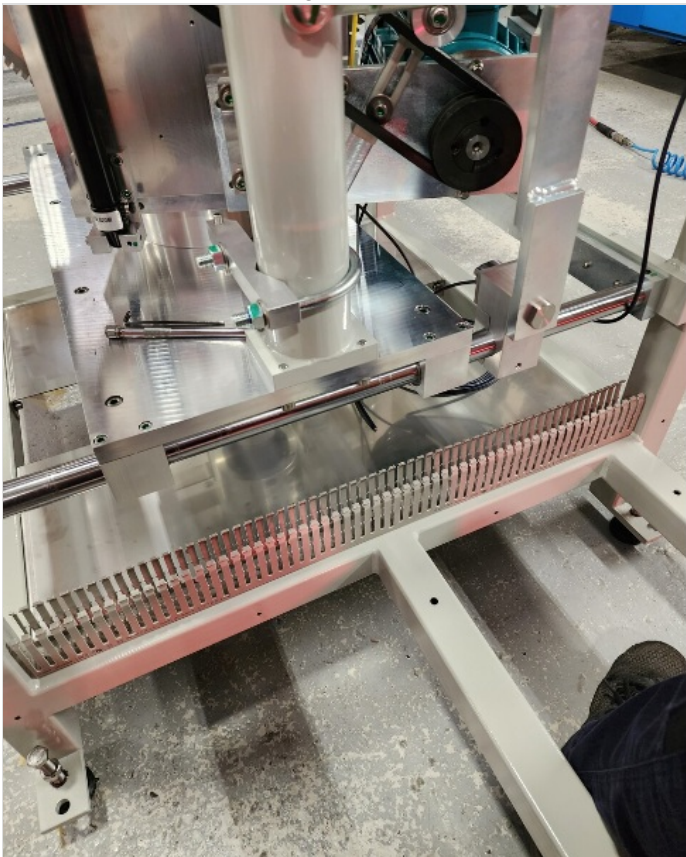



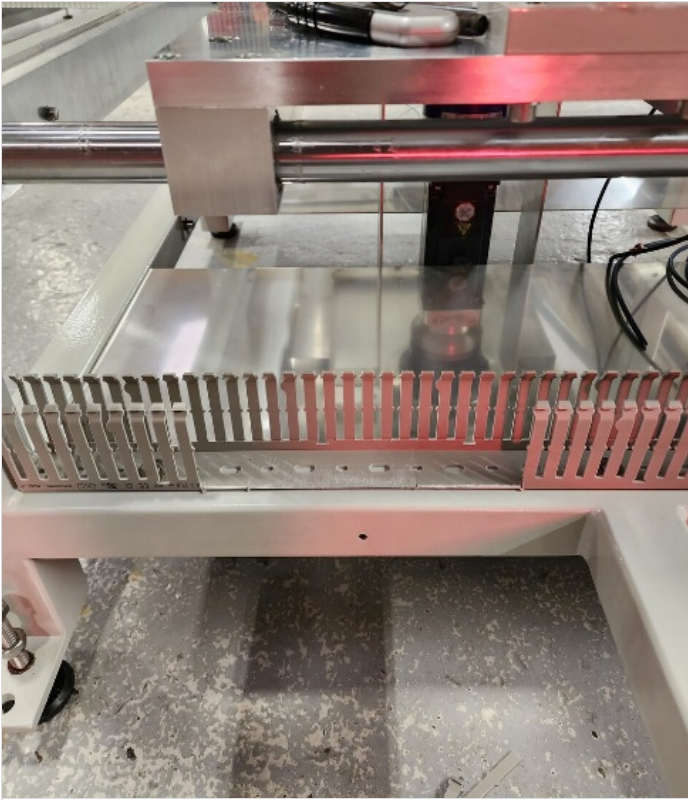

---

## Step 3 - Cut Trunking 2

Cut a section of trunking to fit into area as shown



---

## Step 4 - Fit Air gun bracket

Mark and drill 2 off M5 tapped holes to suit air gun bracket .

Position 15mm as shown from edge of frame

Fix with 2 off M5 x 12 socket caps and M5 motor plate washer

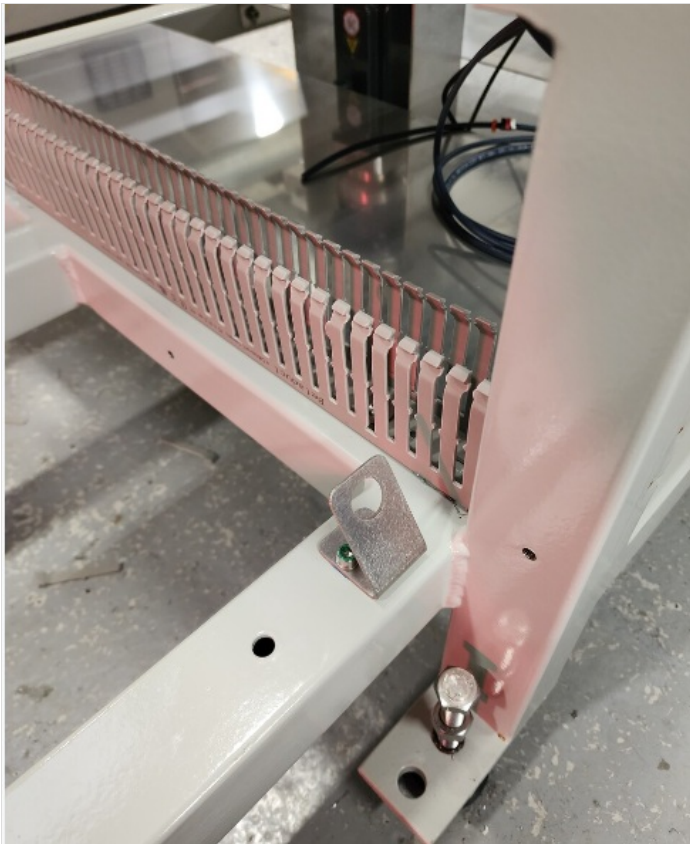

## Step 5 - Fit side sheet

Fit D0004391E Left hand side sheet

Use M6 x 12 socket caps and M6 A form washers

Use 2 off M6 x 10 Counter sunk for top 2 fixing points

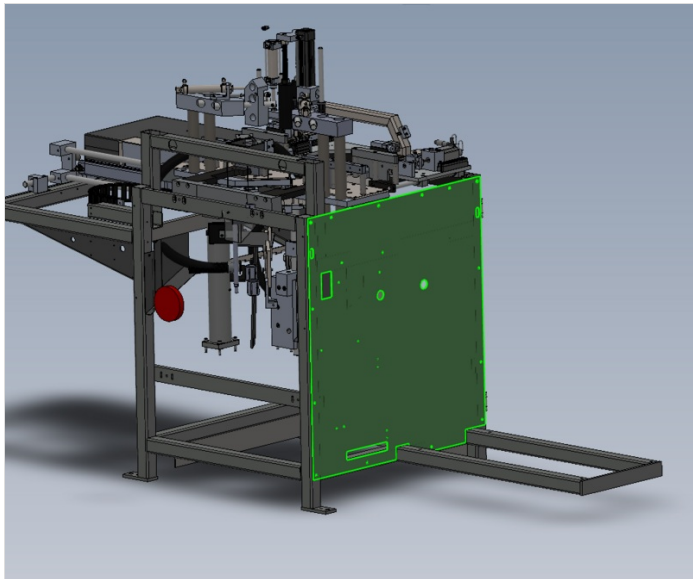







---

## Step 6 - Fit trunking to side sheet

Mark and drill pre cut trunking to fit as shown . Fix with  
M5 x 10 button sockets, penny washers and back off with M5 A forms and dome nuts





---

## Step 7 - Fit ethercat mount plate

Fit ethercat box to mounting plate using M3 x 25 socket caps , M3 A form washers and M3 nuts

Fit ethercat mounting plate to side sheet at position shown , holes will require drilling to suit. Use M6 x 12 socket caps and penny washers, and back off with M6 A form washers and Dome nuts

ECR generated to add holes to side sheet for fixing 18/12/23  
Use attached drawing to add holes until ECR processed





## Step 8 - Fit Regulator bracket

Fit regulator bracket to side sheet using 2 off M5 x 12 socket caps and A form washers

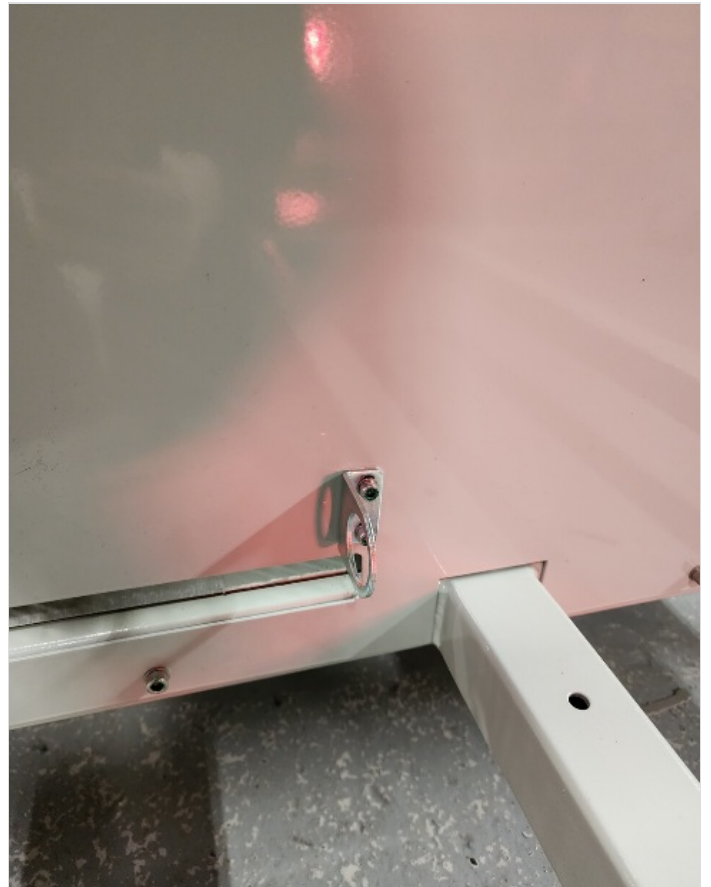
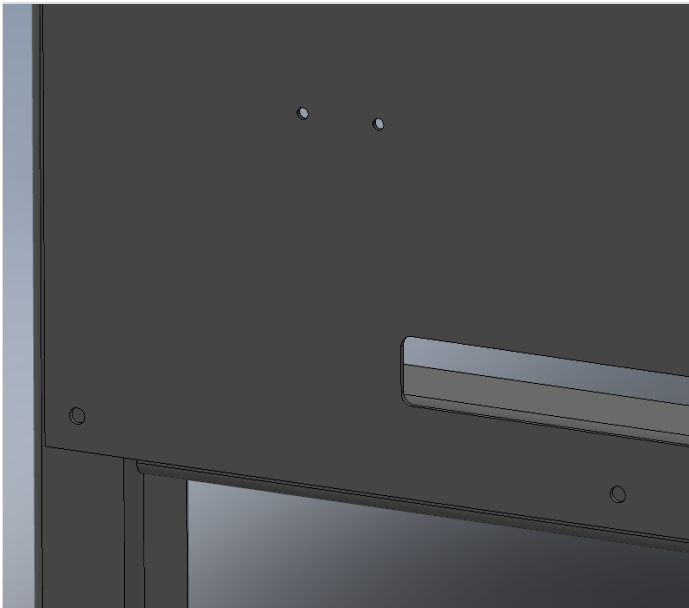



### Step 9 - Assemble air gun regulator

assemble regulator and fit to bracket as shown





---

## Step 10 - Assemble air gun assembly

Assemble air gun assembly to bulk head fitting and fit to air gun bracket







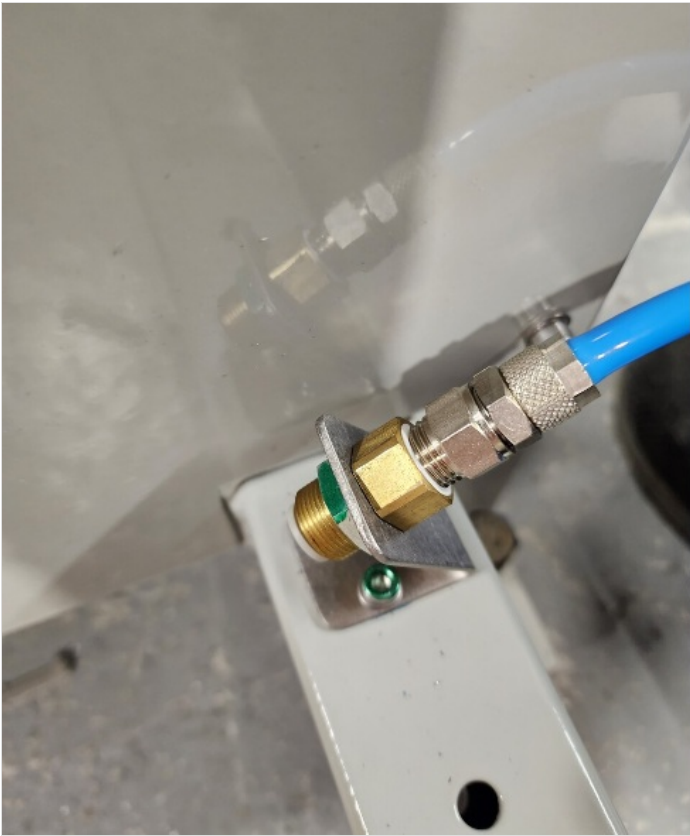

## Step 11 - Connect pipe

Connect 8mm red pipe between air gun regulator and airgun bulkhead

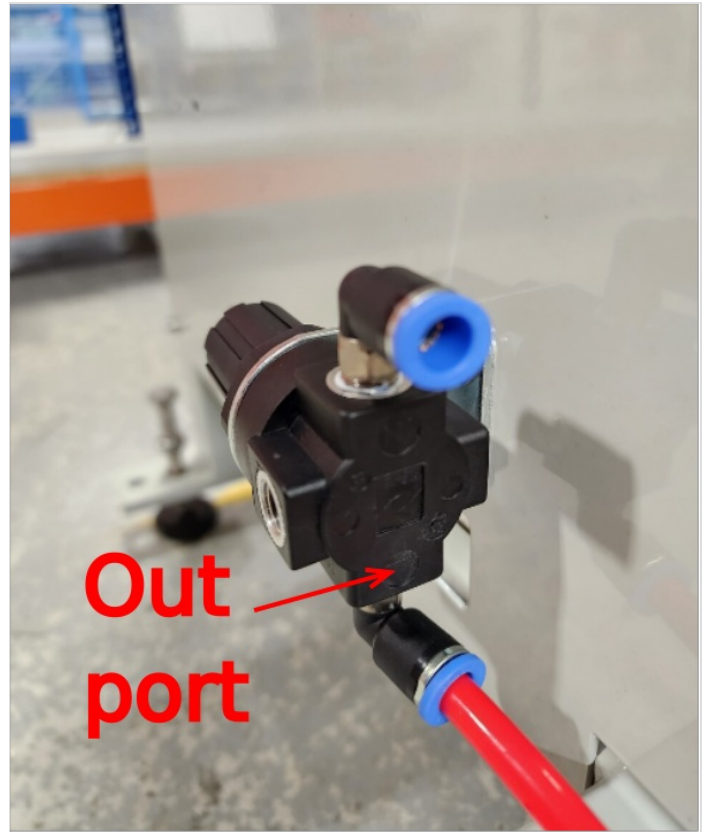
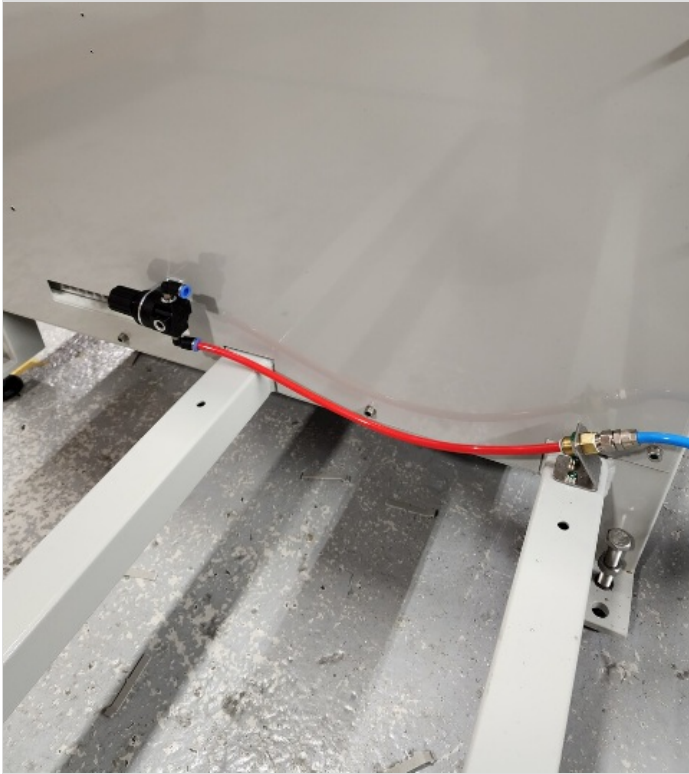

## Step 12 - Position Cabinet

Position cabinet as shown, aligning edges

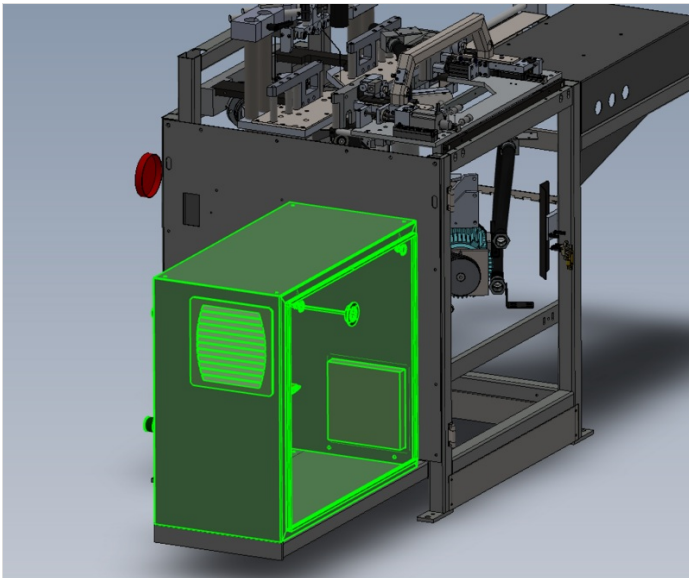



---

## Step 13 - Fix cabinet

Fix cabinet to frame using M8 x 70 socket caps, heavy M8 washers and nyloc nuts

