

R0015292 Install Cylinder Rails and Align

Details for mounting cylinder rails to transfer beams

 Difficulty **Medium**

 Duration **8 hour(s)**

Contents

Introduction

Step 1 - Unless otherwise stated

Step 2 - Position pre built cylinder rails

Step 3 - Adjust delrin wheels front

Step 4 - Adjust Delrin wheels Rear

Step 5 - Check all fasteners

Step 6 - Check movement

Step 7 - Cylinder heights checked on all areas

Step 8 - Set rack meshing

Step 9 - Check for clearance

Step 10 - Caution

Step 11 - Start setup on Cylinder rail 1

Step 12 - Set rack mesh 1

Step 13 - Set Rack mesh point 2

Step 14 - Repeat steps 10 and 11

Step 15 - Align Cylinders to Hepco

Step 16 - Attach pneumatic jig

Step 17 - Set wire line

Step 18 - Adjust cylinder rails 2-7

Step 19 - Quality check

Step 20 - Finalise drive pinions

Step 21 - Add Hard stops

Step 22 - Delrin wheel Quality check

Step 23 - Quality sign off

Step 24 - Quality sign off

Step 25 - Warning

Comments

Introduction

Tools Required

Standard spanner set

Standard hex key set

Tape measure

Wire line
Pneumatic cylinder setting jig

Parts Required

R0015288 Bench Assemble Transfer slid units and cylinder rails
R0015093 Bench Assemble Transfer Beam

Step 1 - Unless otherwise stated

Use Loctite 243 on all fasteners
Use Loctite 572 on all threaded pneumatic connection
Pen mark all fasteners to show finalised



Step 2 - Position pre built cylinder rails

Position Cylinder rail onto transfer beam as shown

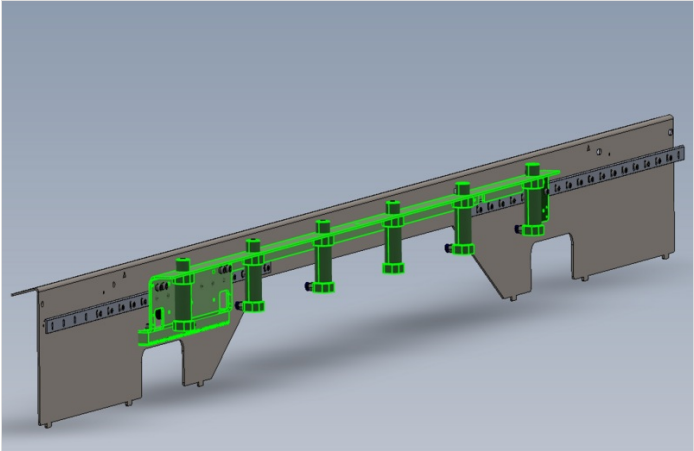

Step 3 - Adjust delrin wheels front

Remove safety bolt stop from cylinder rails
Adjust delrin wheels on section shown

Ensure to use Setting Delrin Transfer Table Wheel Tension To set delrin wheels correctly

⚠ ...Ensure M5 locking nuts are correctly tensioned when set

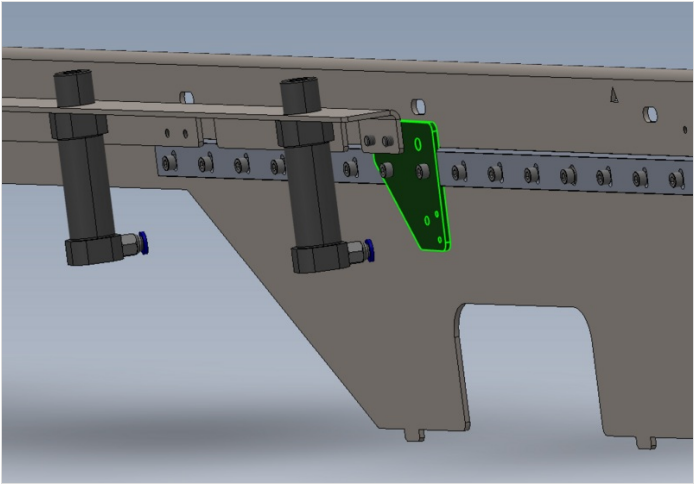

Step 4 - Adjust Delrin wheels Rear

Adjust delrin wheels on section shown

Ensure to use Setting Delrin Transfer Table Wheel Tension To set delrin wheels correctly

Ensure M5 locking nuts are correctly tensioned when set

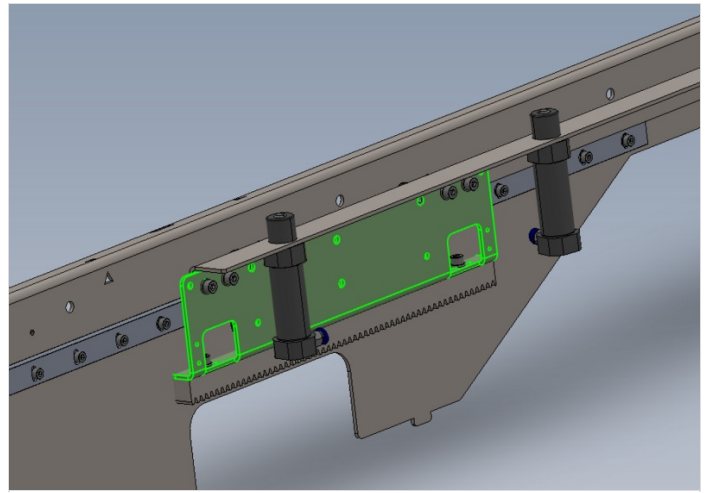

Step 5 - Check all fasteners

Check all fasteners are correctly tensioned

Ensure all delrin wheels are correctly set and all fasteners on delrin wheels are tensioned to final tension



Step 6 - Check movement

Ensure cylinder rail is free moving along transfer beam



Step 7 - Cylinder heights checked on all areas

All cylinders should be checked for correct height position in regards to top face of transfer arms

All cylinders should be below the top face of the transfer arm,

 ...Please check all cylinders including crank C and E as well as the fitted transfer cylinder rails

Check with 2 meter straight edge over tops of transfer arms

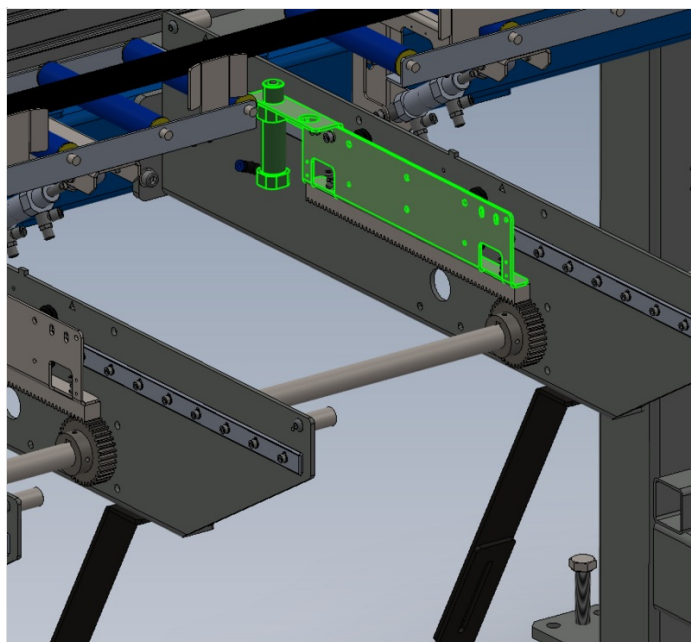
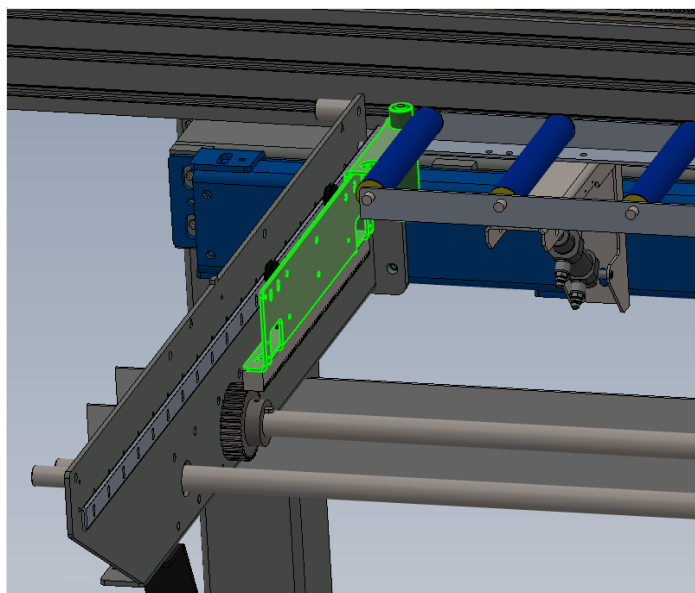
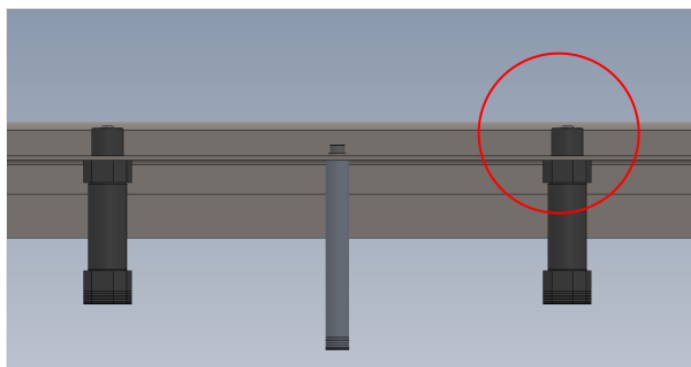
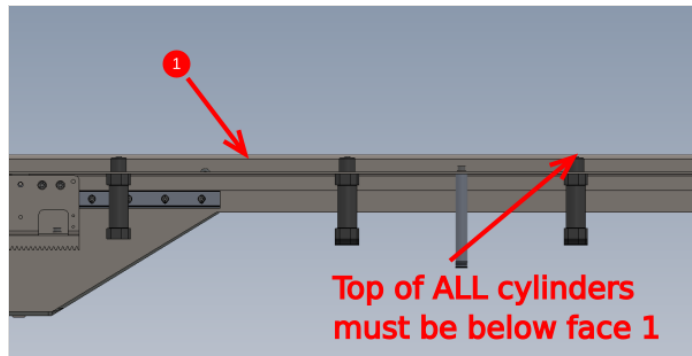

Step 8 - Set rack meshing

Mesh requires setting between slider unit and drive pinion
It is vital that the correct drive meshing is achieved.
Complete the following steps to mesh pinion and drive correctly

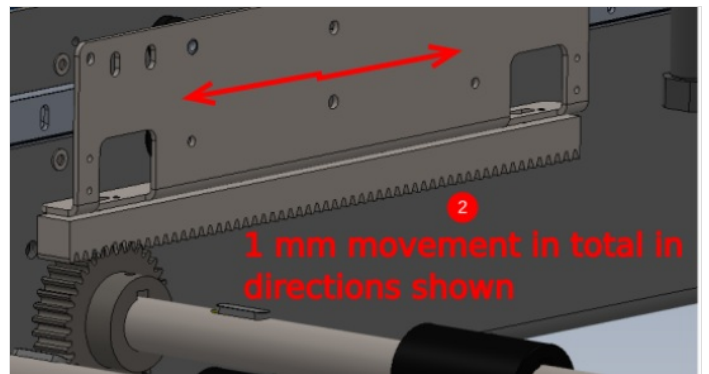
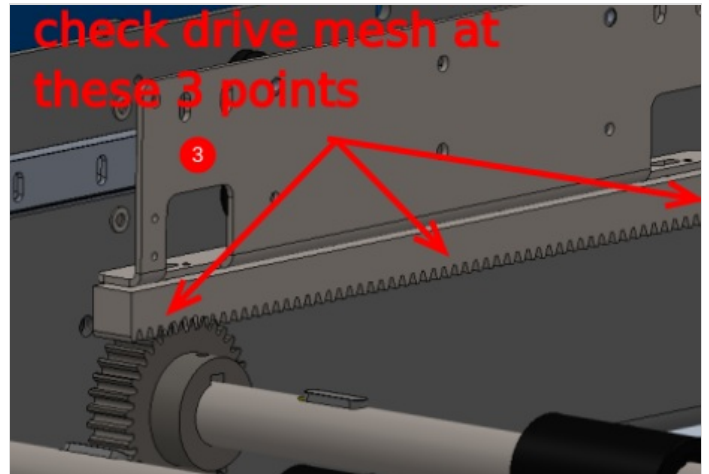
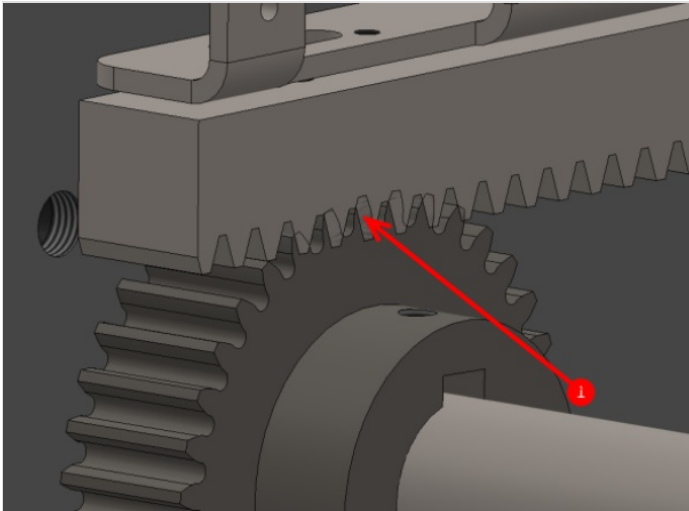

Step 9 - Check for clearance

Once drive racks have been set, it is vital to check that no interference between rack and arm is present. Move racks along full length of travel and check for any fouling



Step 10 - Caution

! ...In the following steps, do not rotate the main drive shaft.
All the meshing can be achieved by repositioning drive pinion allowing individual rack assemblies to be aligned



Step 11 - Start setup on Cylinder rail 1

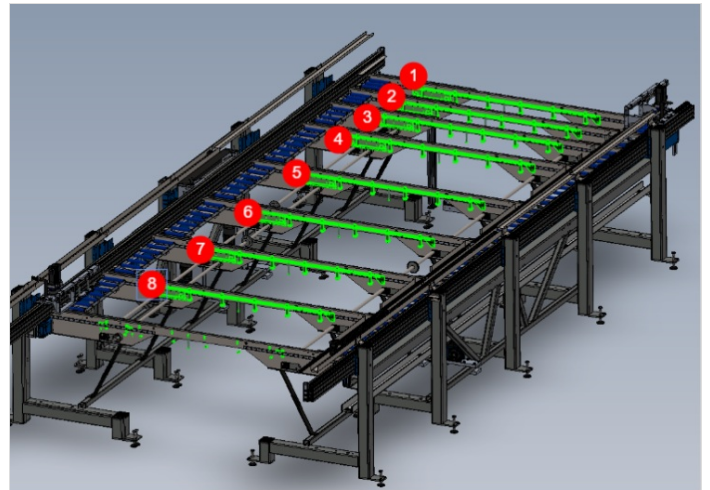

Step 12 - Set rack mesh 1

- 1 Slide drive pinion away from rack , this pinion shou. be loose and free moving
- 2 Move cylinder rail to position shown
- 3 Slide Pinion into position under drive rack
- 4 Adjust Backlash between rack and pinion to give no more than 1mm movement

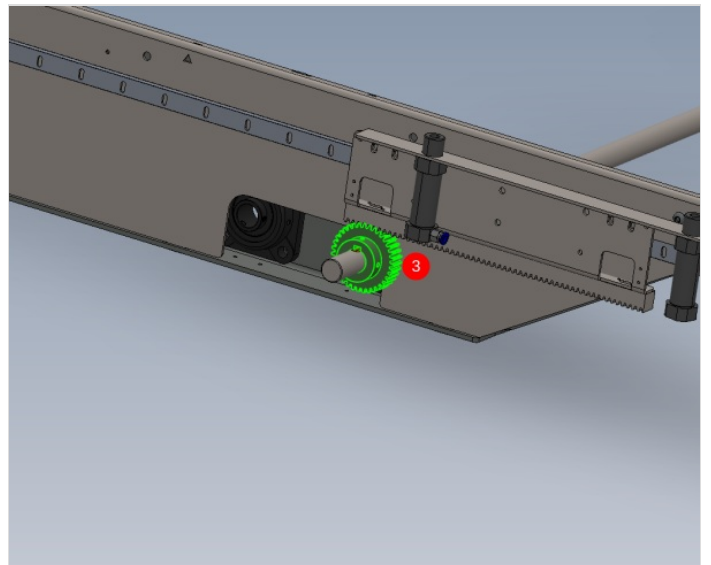
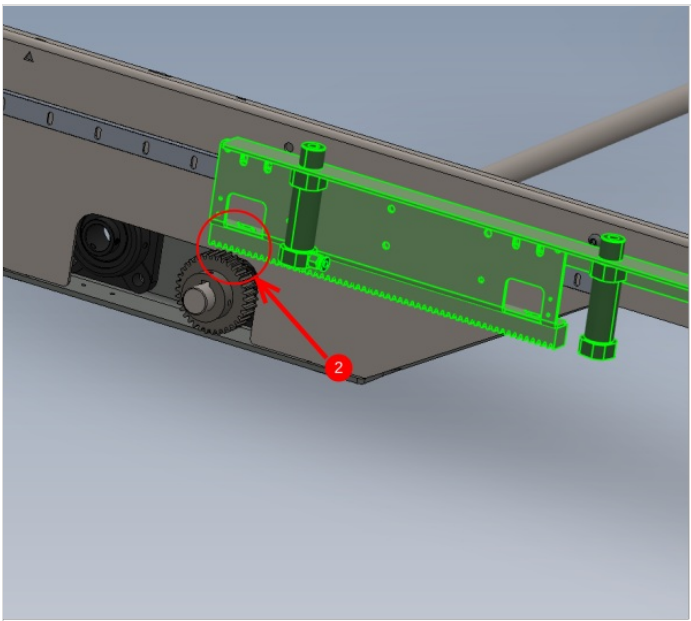
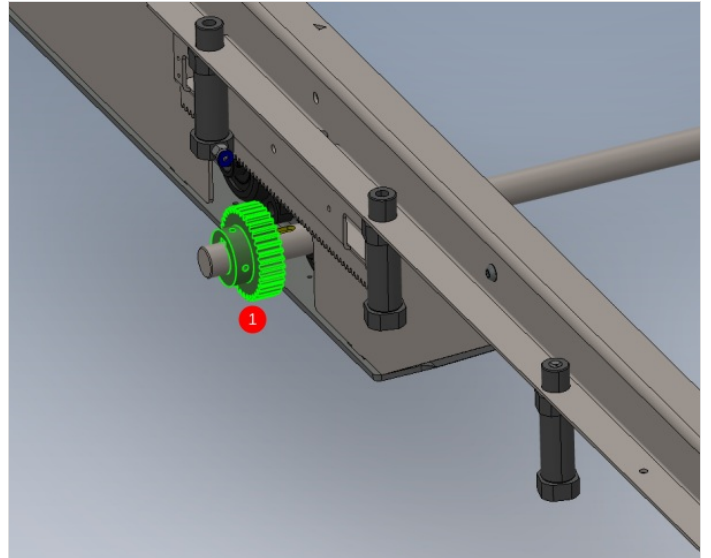
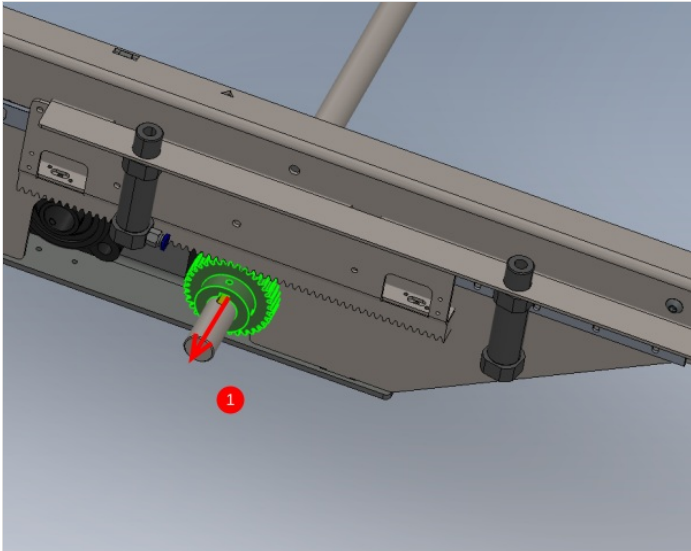

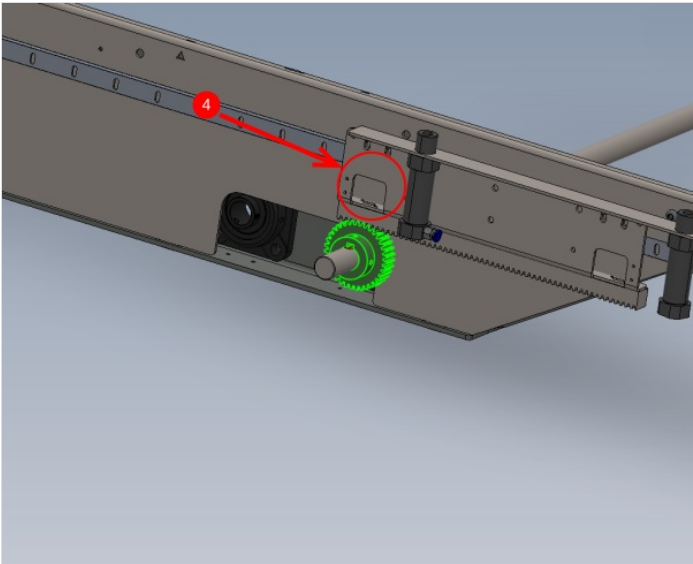

Step 13 - Set Rack mesh point 2

Repeat step 10 but with rack in position shown

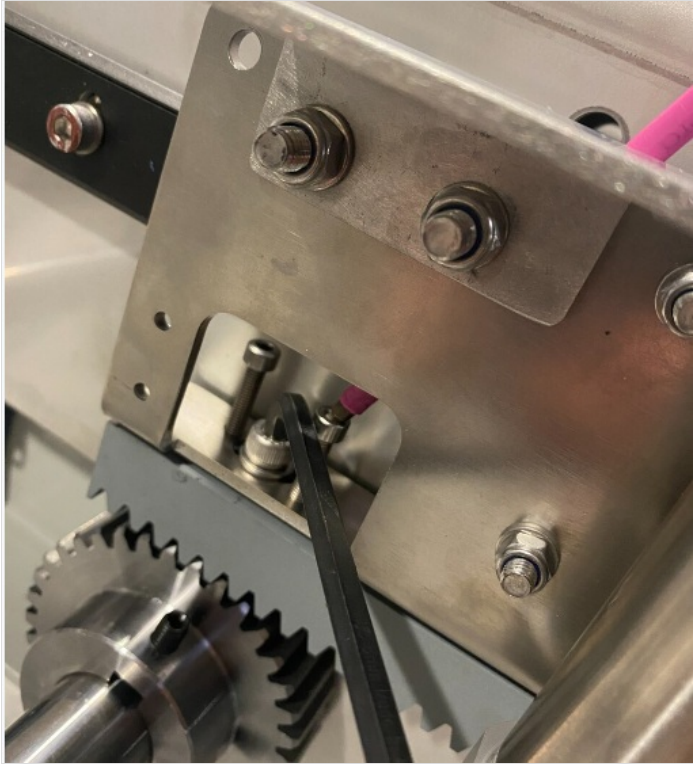
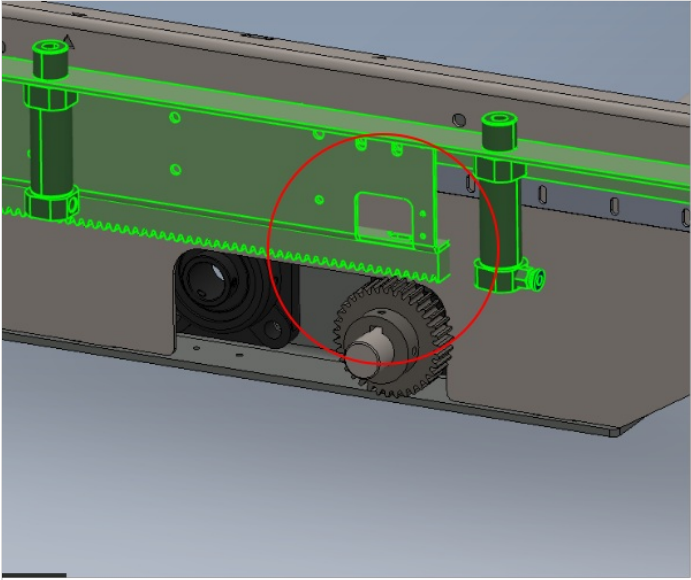

Step 14 - Repeat steps 10 and 11

Repeat steps 10 and 11 for remain 7 off cylinder rails 2-8

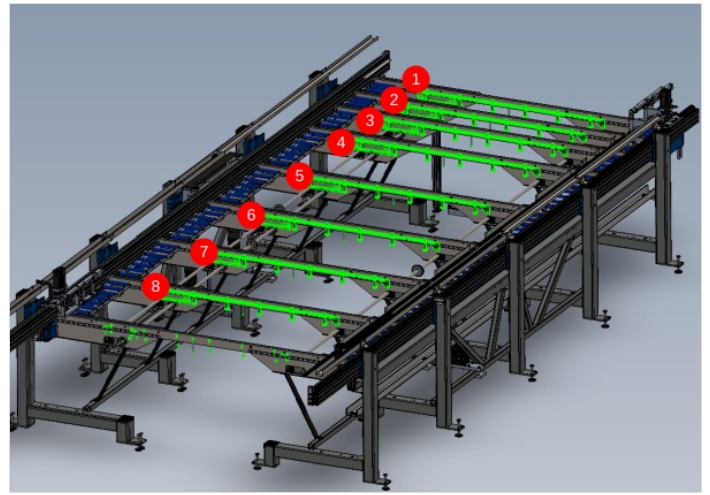

Step 15 - Align Cylinders to Hepco

Set cylinder rails to hepco rail by completing the following steps

1 Set cylinder rails 1 and 8 to same measurement to hepco beam, using same technique of sliding drive pinion out of the way to enable movement

2 For finer tuning of position, Use slots in rack mounting and drive gear position to adjust

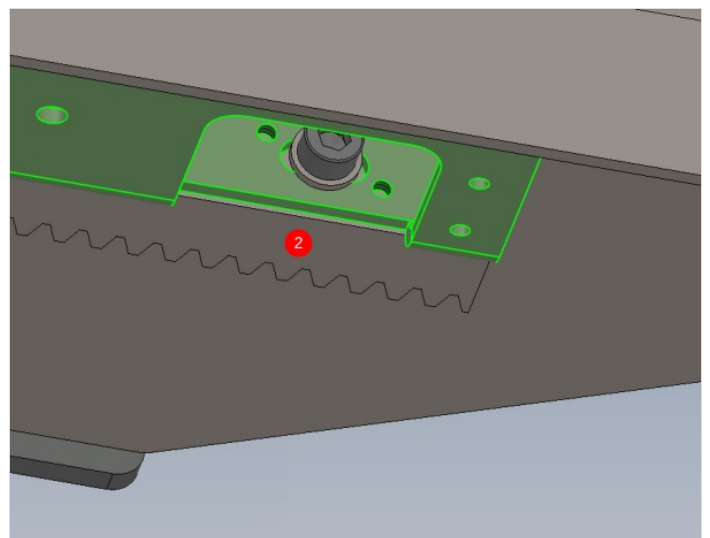
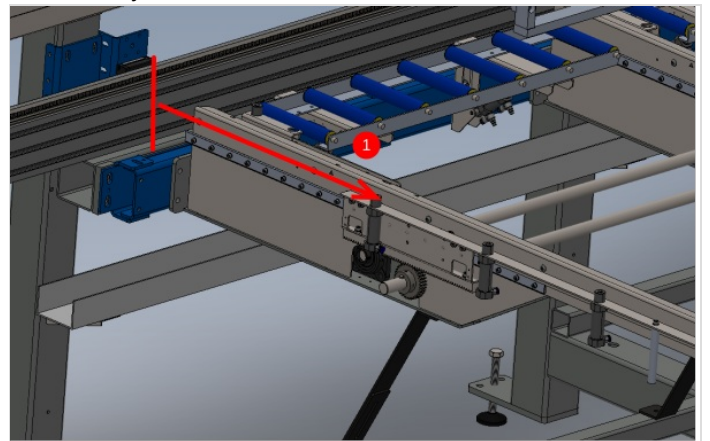
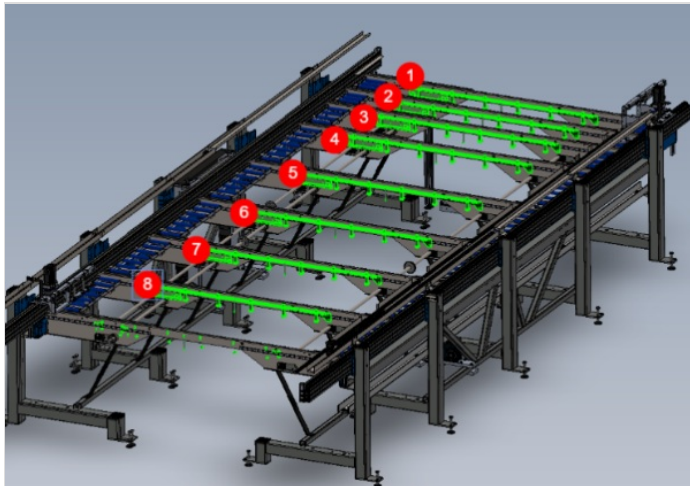

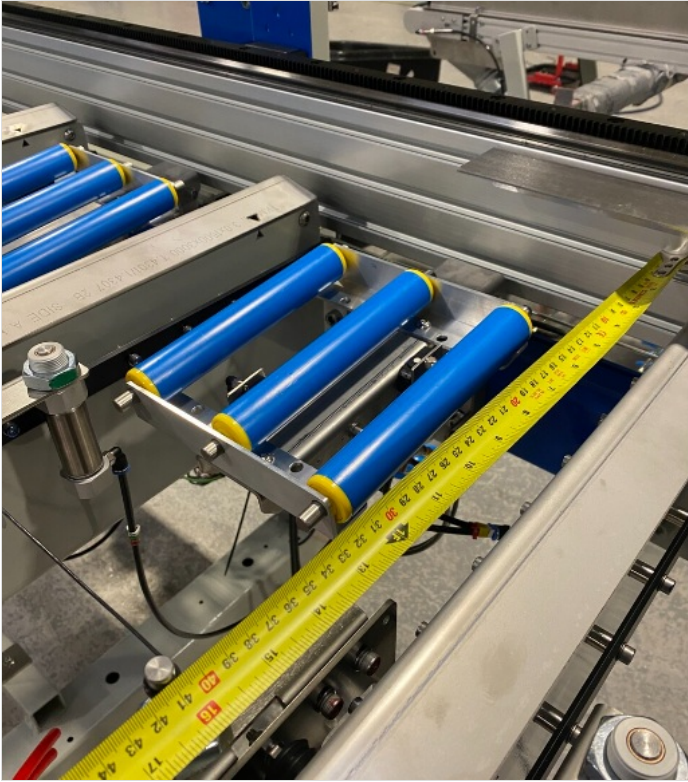

Step 16 - Attach pneumatic jig

Attach pneumatic jig to cylinders , to enable cylinder pistons to be extended



Step 17 - Set wire line

Set wire line between set cylinders 1 and 8

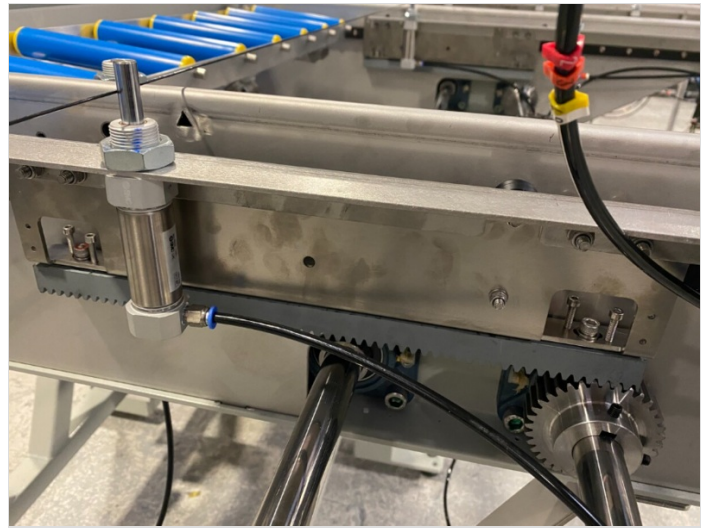

Step 18 - Adjust cylinder rails 2-7

Using the same method, position the remaining cylinder assemblies to the wire line



Step 19 - Quality check

Double check setting by measuring from cylinder piston to hepcos rail on each cylinder assembly

All measurements should be the same $\pm 0.5\text{mm}$

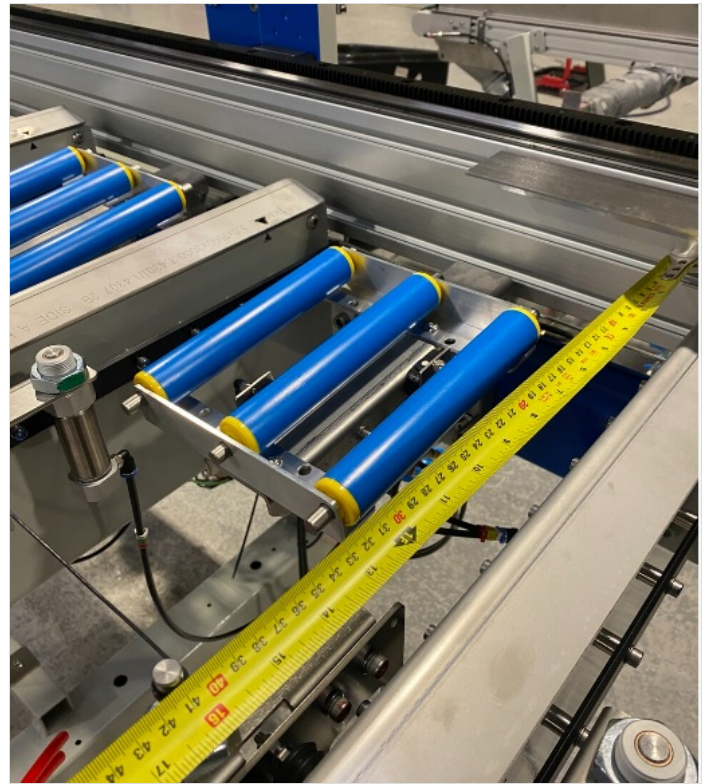
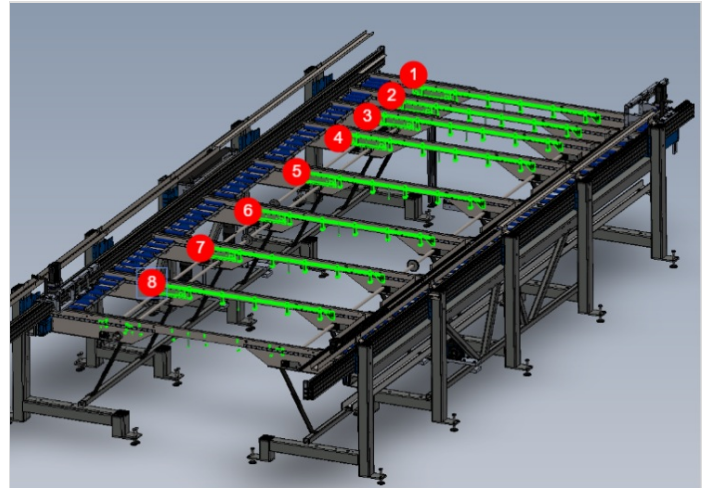

Step 20 - Finalise drive pinions

Remove, apply adhesive and finalise 2 off M6 grub screws per each drive pinion

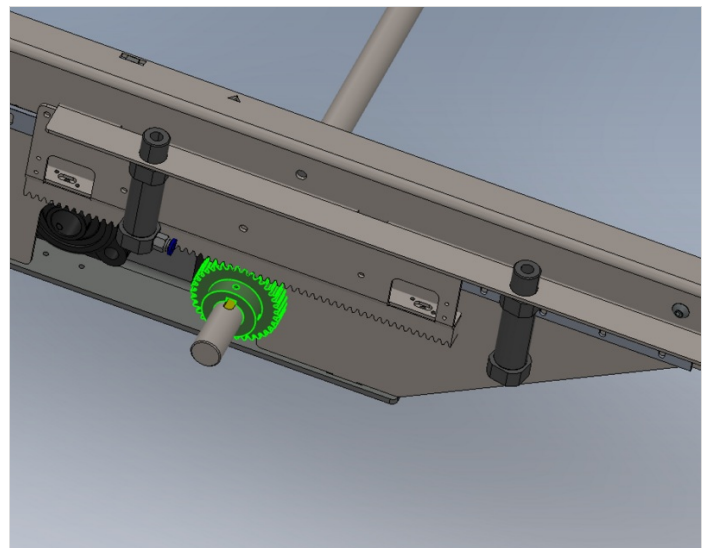

Step 21 - Add Hard stops

Fit hard stop assemblies once alignment is set

Fasteners and size required

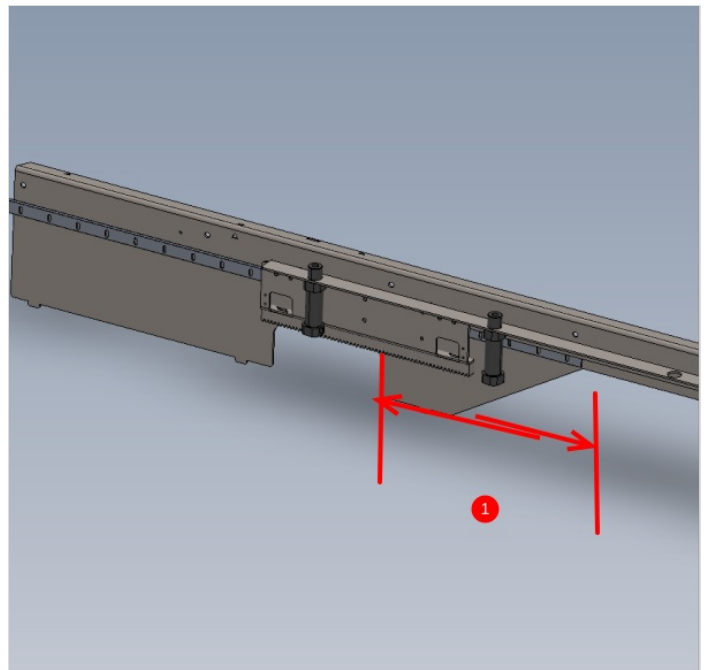
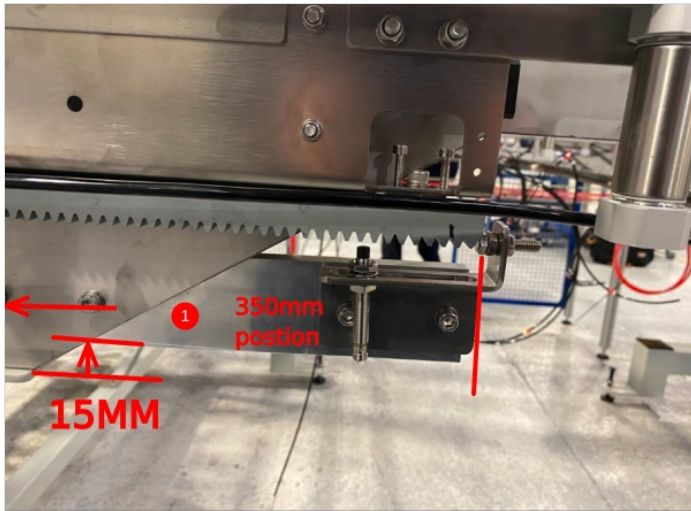

Step 22 - Delrin wheel Quality check

Once all settings have been set, Delrin wheel tension should be rechecked before final sign off

All delrin wheels should be set and be able to be stopped from rotating when held with light finger pressure. . Ensure all delrin wheels are checked on transfer assembly to ensure correct setting



Step 23 - Quality sign off

Sign off Required for all alignment settings



Step 24 - Quality sign off

Sign off Required for all alignment settings



Step 25 - Warning

The next step is vital. Please ensure this is not missed again

