

R0015281 Bench Assemble Transfer Sliders

Instructions to bench assemble transfer sliders

 Difficulty **Medium**

 Duration **2 hour(s)**

Contents

Introduction

Step 1 - Unless otherwise stated

Step 2 - Quality check on part D0015551 Rack mounting plate

Step 3 - Warning!!!

Step 4 - Attach cylinder plate to rack bracket

Step 5 - Attach air fitting

Step 6 - Attach cylinder to bracket

Step 7 - Attach drive rack

Step 8 - Fit concentric Delrin wheels

Step 9 - Fit Eccentric wheels

Comments

Introduction

Tools Required

Standard spanner set

Standard hex key set

Parts Required

D0015551 x 9

D0015255 x 9

D0015549 x 9

P0001111 x 9

P0000010 x 9

B0001160 x 36

B0001161 x 18

B0001162 x 18

Step 1 - Unless otherwise stated

Use Loctite 243 on all fasteners

Use Loctite 570 on all threaded pneumatic connections

Pen mark all bolts when finalised



Step 2 - Quality check on part D0015551 Rack mounting plate

Check that part B0001162 sits flush into hole on rack mounting plate. It may be required to remove burrs from manufacture to achieve this

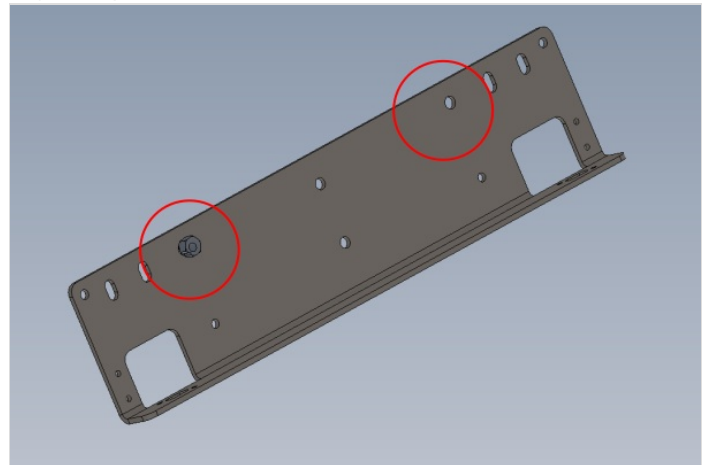

Step 3 - Warning!!!

⚠ ...It is vital the correct bolts are used in this assembly M5 x 30 SET bolts must be used, not socket caps

image attached to clarify what a set bolt is



Step 4 - Attach cylinder plate to rack bracket

9 off

1 Attach D0015550 to D0015551 as shown. Use 2 off M6 x 10 socket caps with A form washers

2 Ensure bracket is positioned bottom slot as shown and faces marked are parallel

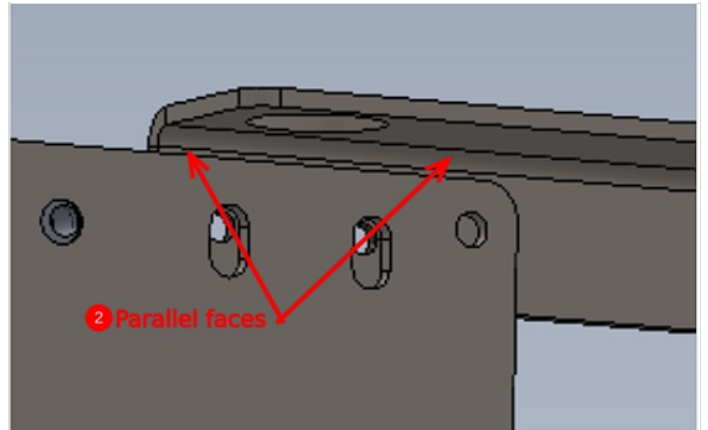

Step 5 - Attach air fitting

9 off

Attach P0000010 elbow fitting to cylinder P0001111 as shown

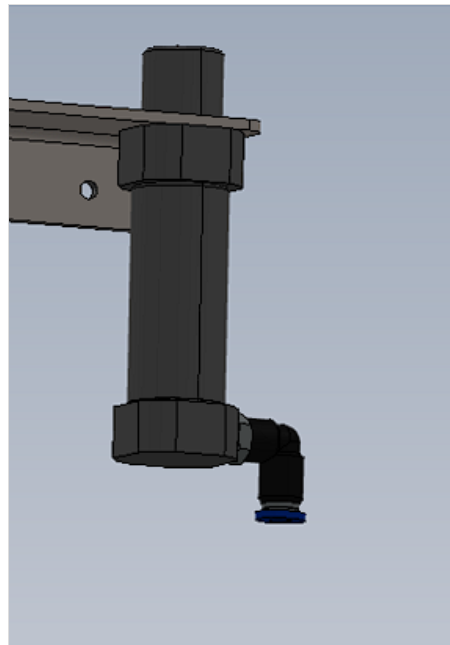

Step 6 - Attach cylinder to bracket

9 off

Mount cylinder to bracket as shown. Loctite 243 should be used on cylinder locking nut

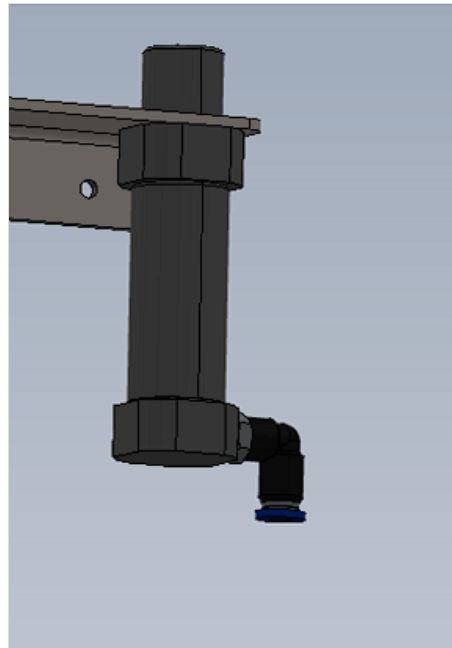

Step 7 - Attach drive rack

Attach drive rack D0015255 to assembly as shown.

Use m6 x 16 socket caps, M6 A form washers and M4 x 20 socket caps

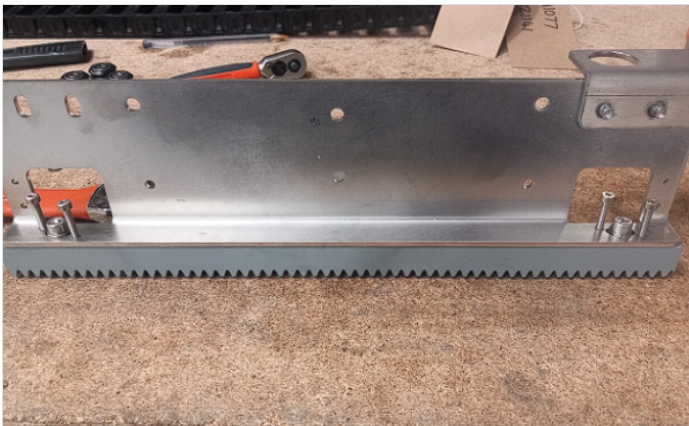

Step 8 - Fit concentric Delrin wheels

2 off on each assembly

9 off in total

 ..Ensure Set bolts are used

Fit concentric wheels to assembly .

Assemble with in this order

M5 x 30 set bolt- M5 A form washer- Delrin wheel assembly B0001160- spacer B0001161 - Main assembly - A form washer- M5 Nyloc nut



Step 9 - Fit Eccentric wheels

2 off on each assembly

9 off in total

1 Check that part B0001162 sits flush into hole on rack mounting plate. It may be required to remove burrs from manufacture to achieve this

2 Attach delrin wheel in this order.

M5 x 30 Set bolt-M5 A form washer-Delrin Wheel (B0001160) -Eccentric cam(B0001162)- Assembly - M5 A Form Washer- M5 Nyloc nut

Do not add final tension to this wheel assembly as adjustment will be required at a later point

