

R0015269 Fit Frame ancillaries

Instructions to fit ancillaries such as wire basket

 Difficulty **Medium**

 Duration **2 hour(s)**

Contents

Introduction

Step 1 - Unless otherwise stated

Step 2 - Fit basket brackets

Step 3 - Fit first wire basket

Step 4 - Fit 2nd wire basket

Step 5 - Fit 3rd wire basket

Step 6 - Fix wire baskets

Step 7 - levelling bracket positions

Step 8 - Drill and mount levelling brackets

Step 9 - Mount cabinet braces

Comments

Introduction

Tools Required

Standard hex key set

125mm cutting disc /grinder

Standard spanner set

Standard hss drills

Standard tap set

Engineers level

Tape measure

Parts Required

A0001060 x 6

A0001065 x 2

A0001061 x 6

D0015611 x 2

D0015070B x 2

Step 1 - Unless otherwise stated

Use loctite 243 on all fasteners

Use Loctite 572 on all threaded pneumatic connections

Pen mark all bolts to show finalised



Step 2 - Fit basket brackets

Fit 6 off basket support bracket to pre drilled holes at indicated points .

Secure using M8 x 20 socket caps and Large M8 washers

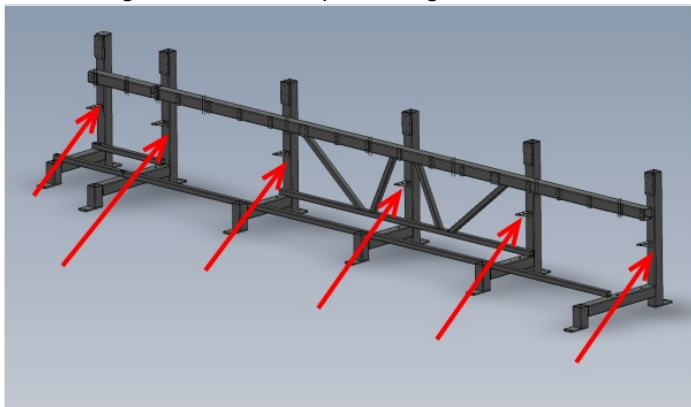

Step 3 - Fit first wire basket

Ensure all wire baskets are fitted to the shown slots

1 Lay 1 full length of A0001065 wire basket between these points

2 Position end to be mid bracket

3 Allow overhang this end

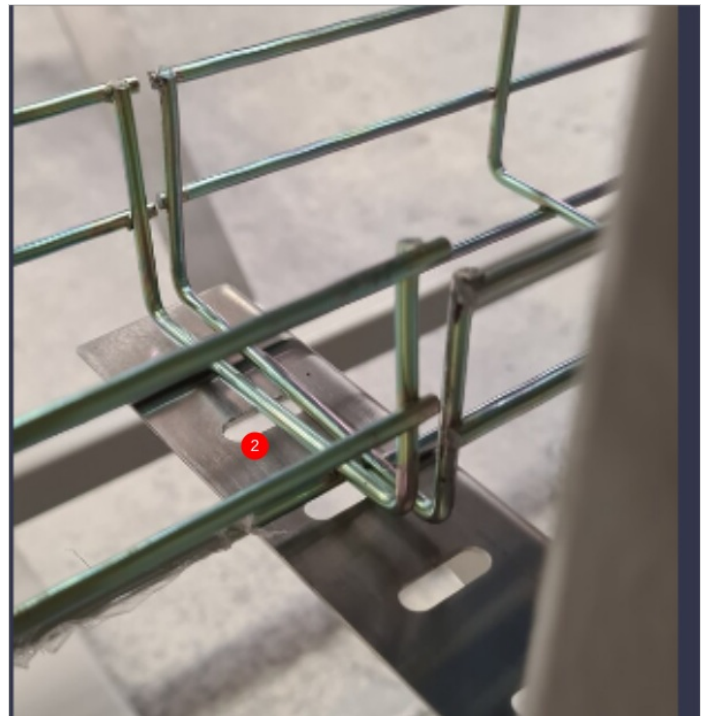
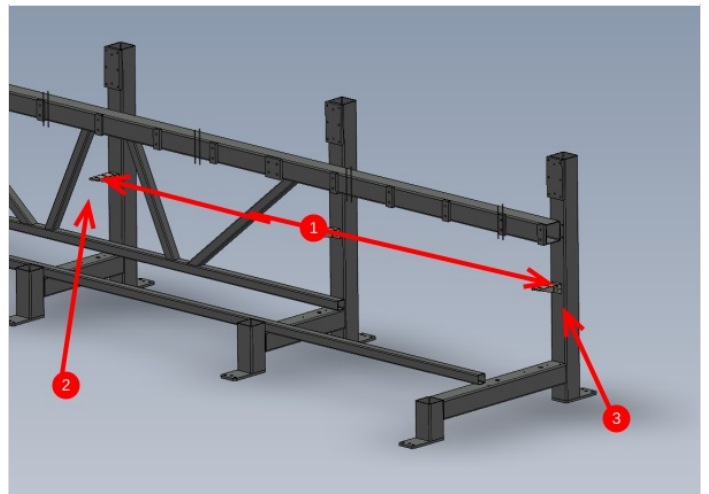

Step 4 - Fit 2nd wire basket

1 Measure and cut a piece of wire A0001065 wire basket to bridge between indicated points.

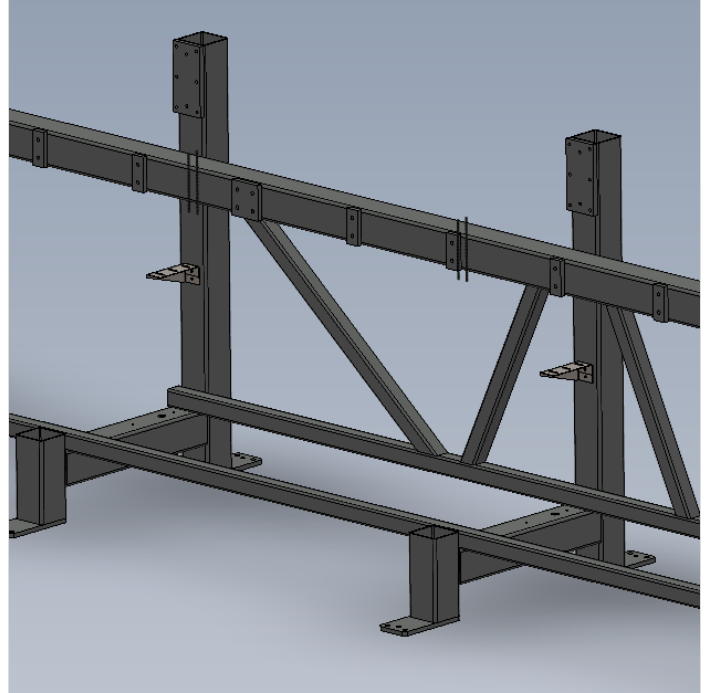
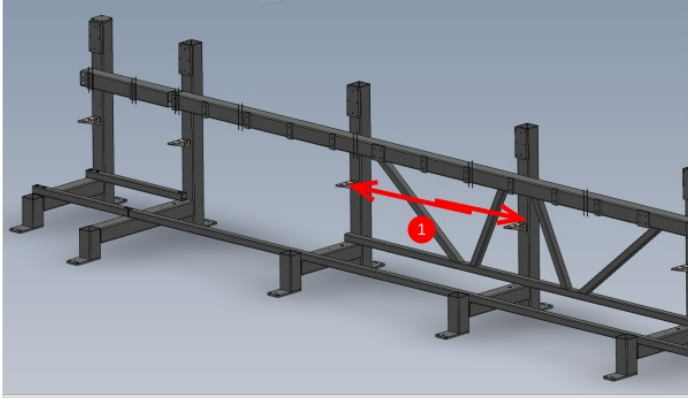

Step 5 - Fit 3rd wire basket

2 Measure and cut section of A0001065 to bridge between point 2 indicated

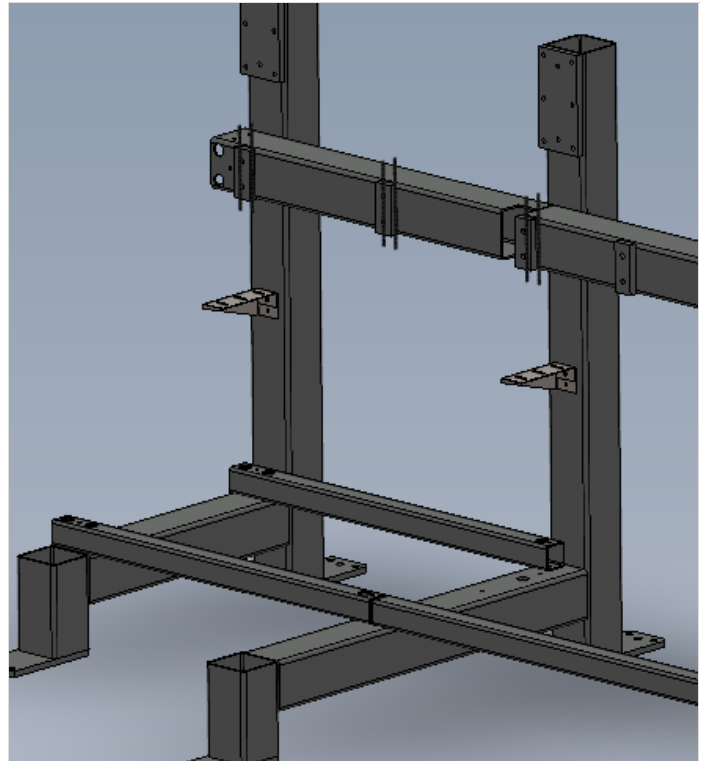
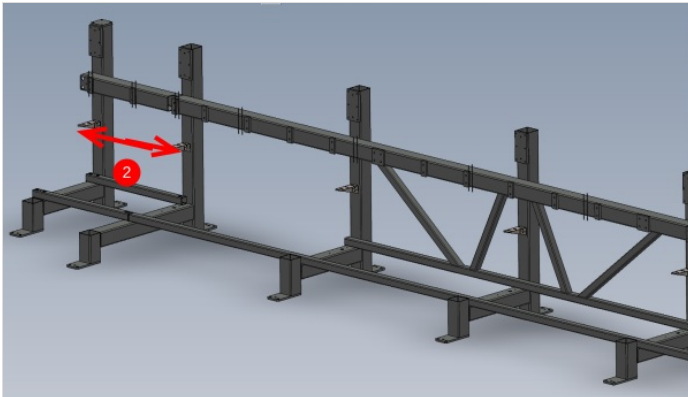

Step 6 - Fix wire baskets

Fix wire baskets to support brackets using 6 off A0001061

Use M6 x 20 button sockets, M6 penny washers and m6 nyloc nuts

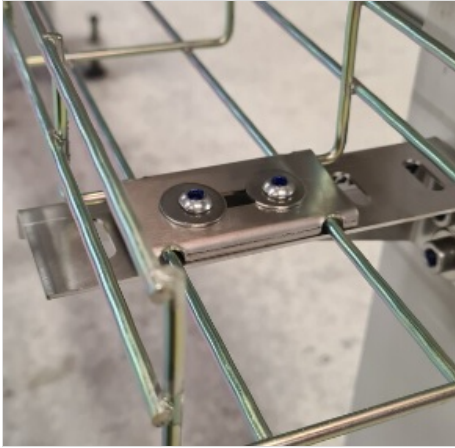

Step 7 - levelling bracket positions

2 off Leveling brackets D0015611 are fitted to indicated positions

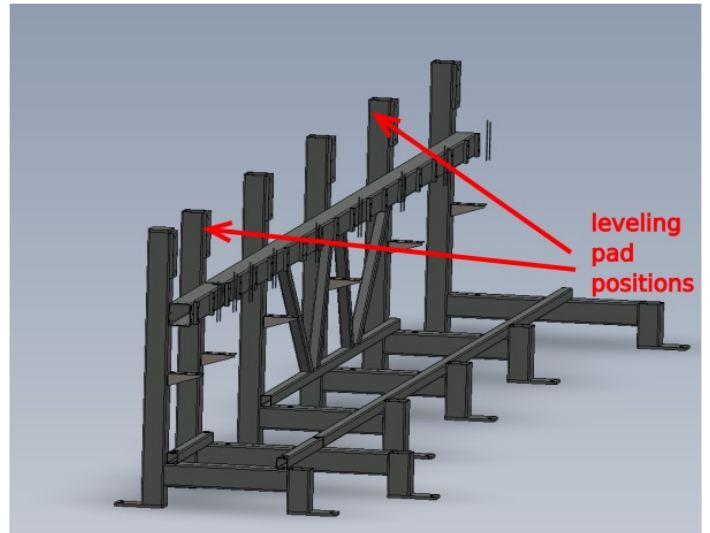

Step 8 - Drill and mount levelling brackets

Position bracket as shown and drill 1 off M6 tapped hole and secure with M6 x 20 socket cap and heavy washer. Use engineers level to level bracket, then mark and drill second M6 tapped hole.

Finalise fasteners, whilst using level to ensure bracket remains level on the indicated plain.

Repeat for 2nd bracket position

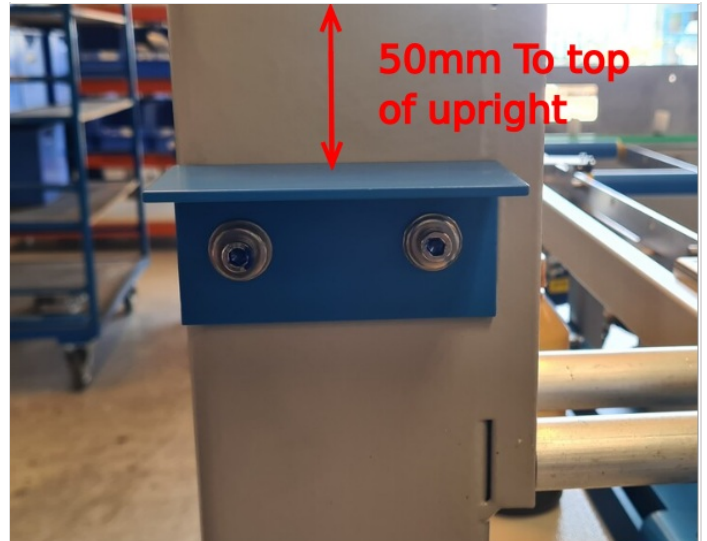

Step 9 - Mount cabinet braces

Mount 2 off D0015070B cabinet braces to indicated point on main frame

Use 4 off M8 x 30 socket caps and Heavy M8 washers to secure

