

# R0015266B mount completed assemblies

Instructions to mount pre built assemblies to frame

 Difficulty **Medium**

 Duration **2 hour(s)**

## Contents

Introduction

Step 1 - Unless otherwise stated

Step 2 - Mount electrical cabinet brackets

Step 3 - Fit pre built cabinet

Step 4 - Sensor bar orientation

Step 5 - Attach sensor rail 1

Step 6 - Attach sensor rails

Step 7 - Mount sensors

Step 8 - Mount Loader wheel assembly

Step 9 - Adjust position of loader wheel

Step 10 - Fit keyboard Mount

Step 11 -

Comments

## Introduction

### Tools Required

Standard hex key set

### Parts Required

D0015432 Spacer: Ø25.4 x 100mm (12.7mm ID) x 10

D0015479 Sensor Mount Rail 1450 mm Long x 4

D0015480 Sensor Mount Rail 825 Long x 1

F0000299 T Nut Sub Insert M6 (Fat) x 16

R0015074 Pre assembled keyboard mount and buttons

R0015030B Bench Assembly Loader Wheel

R0015080 Bench assemble sensor rail

R0015271 Mount buffer bars ( pre fitted to frame )

R0015351 Mount monitor to frame (pre fitted to frame)

## Step 1 - Unless otherwise stated

Use loctite 243 on all fasteners

Use Loctite 572 on all threaded pneumatic connections

Pen mark all bolts to show finalised



---

## Step 2 - Mount electrical cabinet brackets

install 2 of mounting brackets (D15070B) using 4 of M8 x 20mm cap head and 4 of m8 a form washers. DO NOT TIGHTEN AT THIS POINT.

Photo  
Required

---

## Step 3 - Fit pre built cabinet

lift cabinet into place and fasten using 4 of M8 x 70mm cap head, 4 of m8 nylock nuts, 8 of m8 penny washers. tighten all 4 cabinet bolts and all 4 bracket bolts.

Photo  
Required

## Step 4 - Sensor bar orientation

All sensor rails have one slotted and one standard fixing hole

For R-L machines slot should always be on the right hand side when viewed from front of machine

For L-R Machines, slot should always be on the left hand side when viewed from front of machine

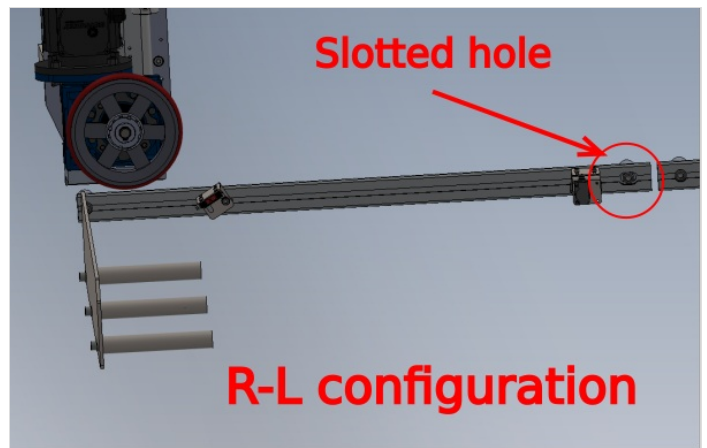

## Step 5 - Attach sensor rail 1

Use M10 x 120 socket caps to secure sensor rail parts to frame

Attach D0015480 Sensor Mount Rail 825 Long with 2 off D0015432 Spacer: Ø25.4 x 100mm (12.7mm ID)

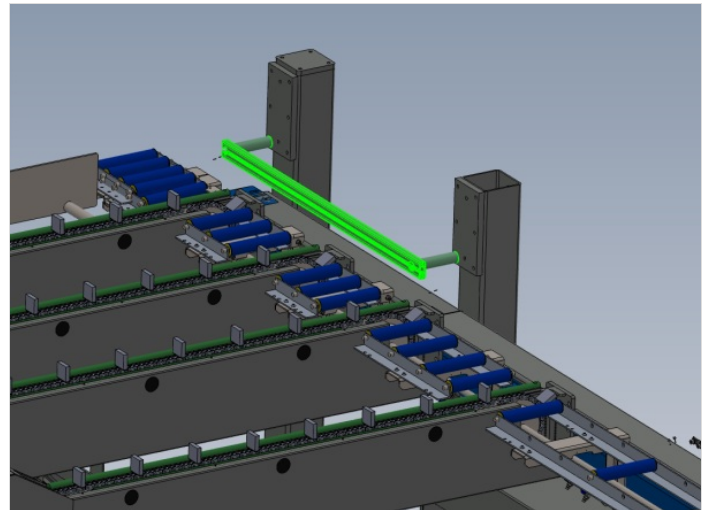

## Step 6 - Attach sensor rails

Use M10 x 120 socket caps to secure sensor rail parts to frame

Attach 4 off D0015479 Sensor Mount Rail 1450 mm Long with 8 off D0015432 Spacer: Ø25.4 x 100mm (12.7mm ID)

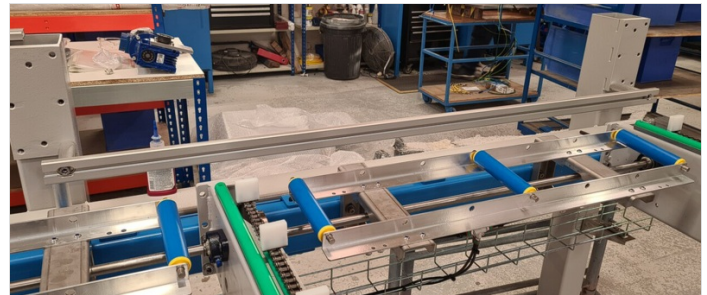
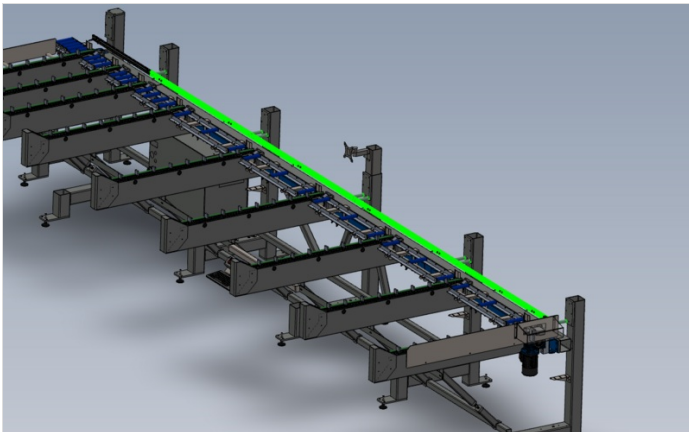

# Step 7 - Mount sensors

Mount sensors from assembly R0015080 with F0000299 M6 D nuts and M6 x 12 socket caps with A form washers

Use Drawing shown for positions , and images for orientation

Ensure drawing is followed for positions of sensors. These measurements are to set the sensors in a standard position. Commission team may alter these on test, but for production adhere to measurements given

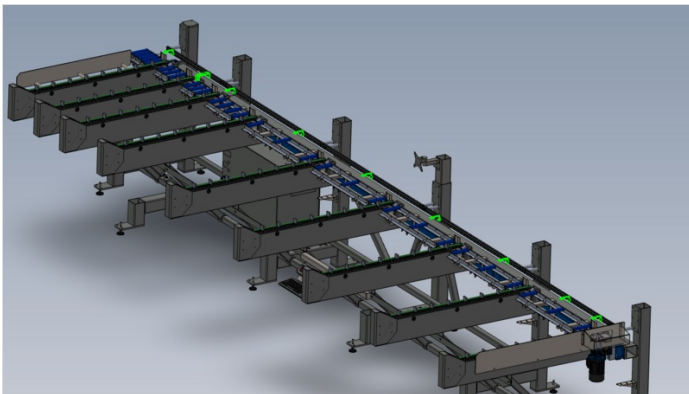
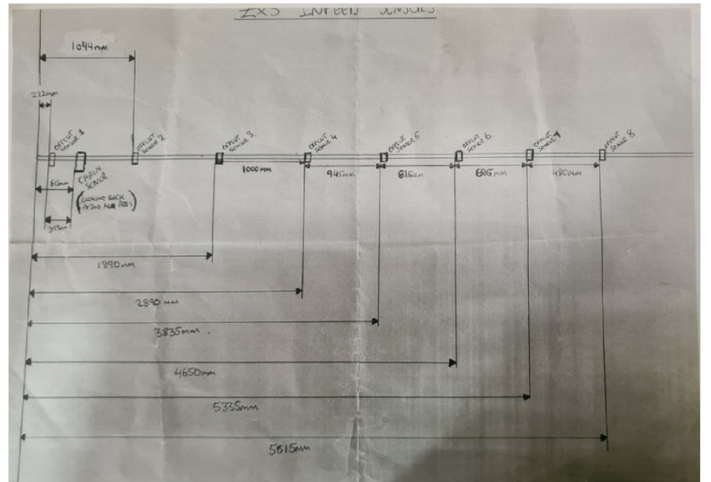
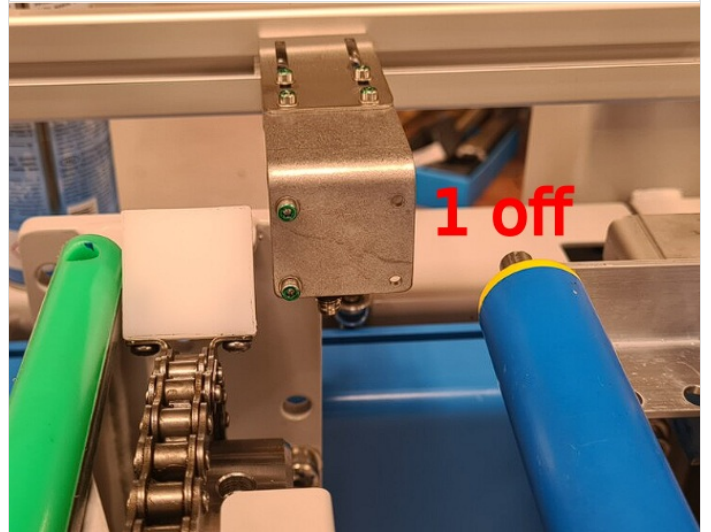
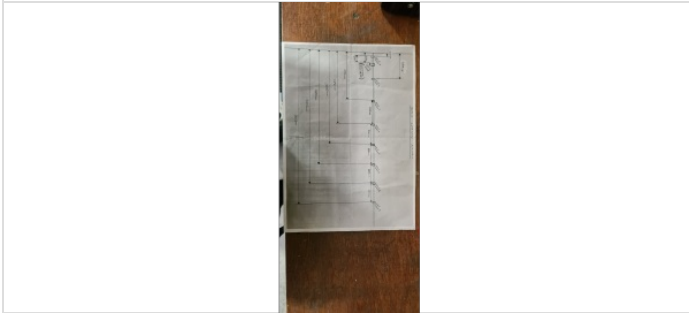

## Step 8 - Mount Loader wheel assembly

Mount loader wheel assemble to frame Using M10 x 30 socket caps with large M10 penny washers (40mm diameter)

### Quality check

Loader wheel must be less than 2mm above the sensor rail maytec bar when cylinder fully extended

1 When loader wheel pulley is in its lowest position it must not hit the sensor rail assembly. If contact is evident follow step 2

2 Use Washers as spacers ( size required ) to lift the assembly up from the frame mounting point and create clearance between the loader wheel and the sensor rail. Ensure maximum gap between loader wheel and sensor rail is not exceeded when adjusting height position of loader assembly.

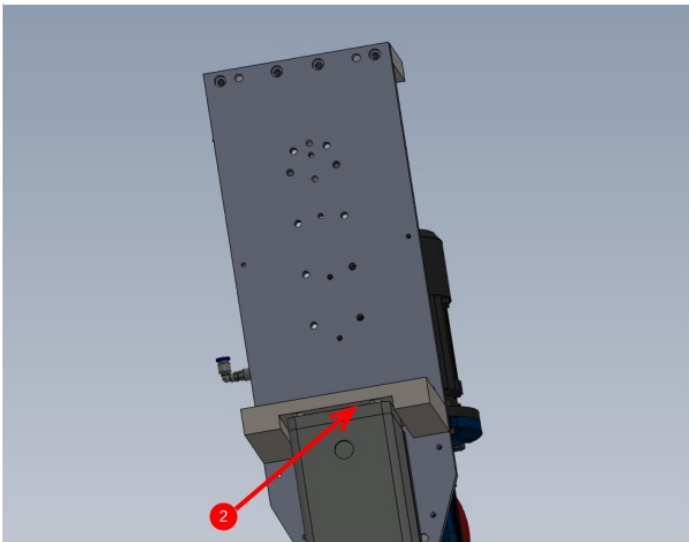
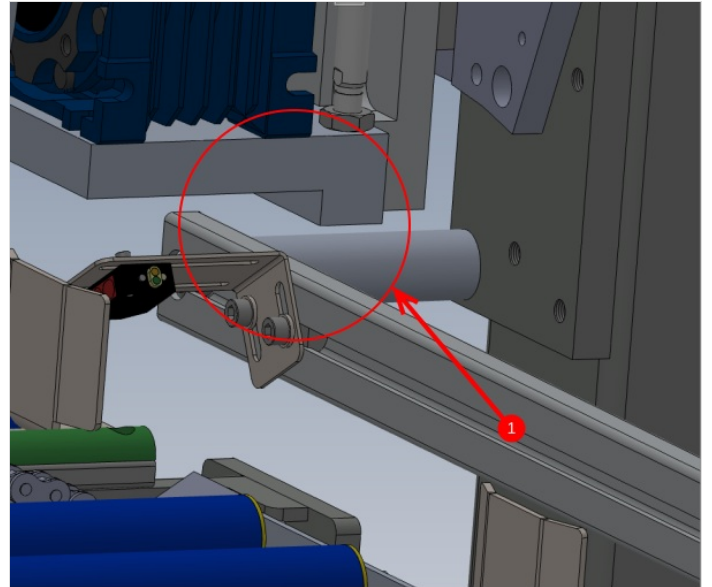
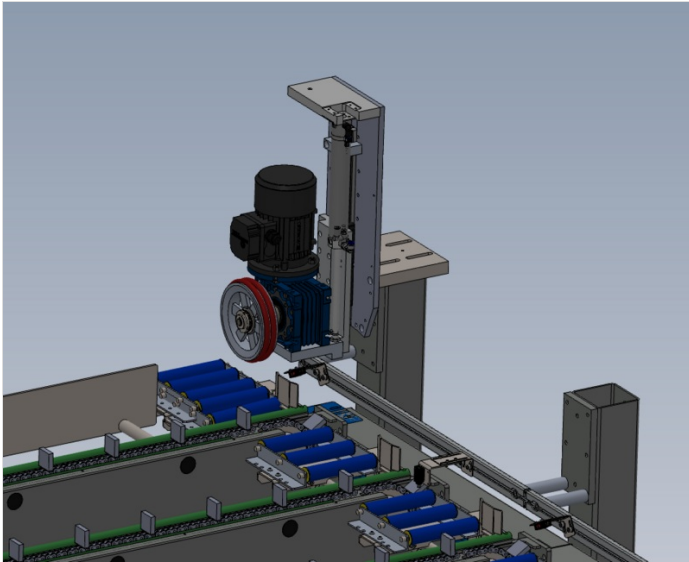



## Step 9 - Adjust position of loader wheel

Set position of loader to 32mm as shown

Measurement is taken from front face of backfence to centre of loader wheel

Finalise fasteners once set

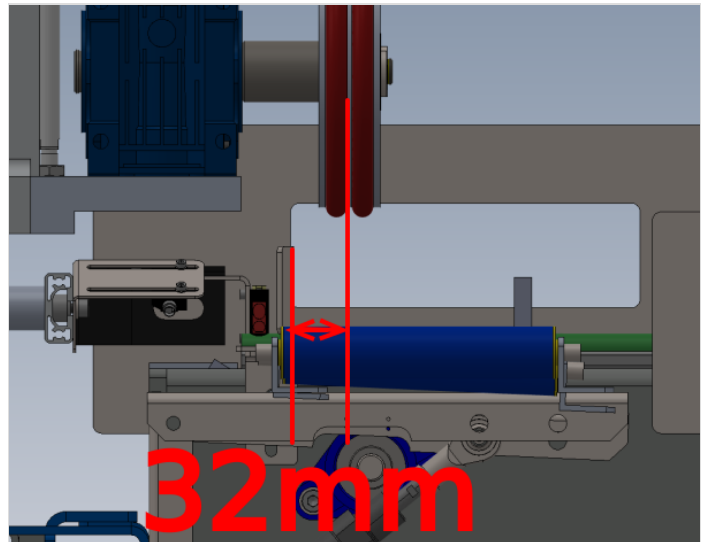
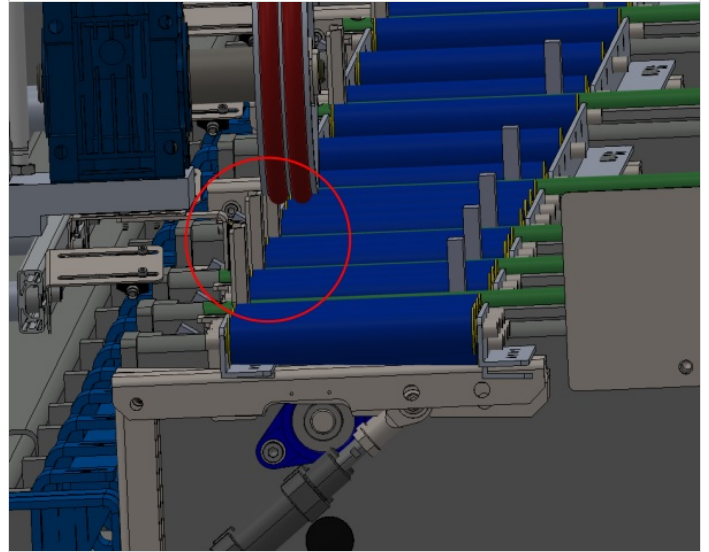
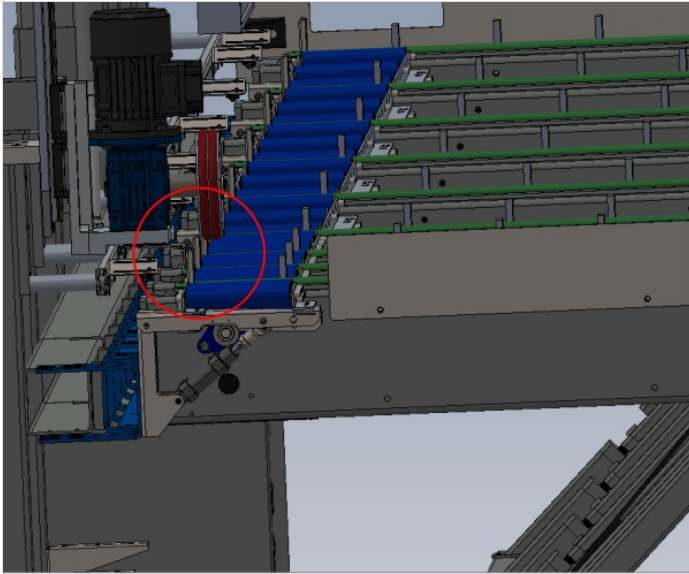

---

## Step 10 - Fit keyboard Mount

Better picture required please

Fit pre assembled keyboard mount R0015074

Fix with M8 35 socket caps , M8 motor plate washers and M8 Nyloc nuts

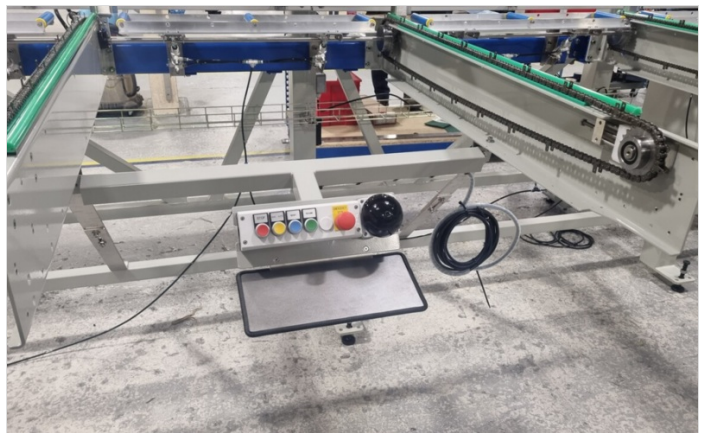
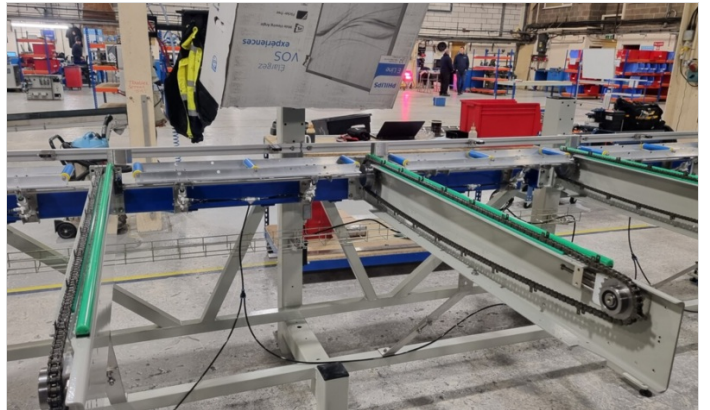
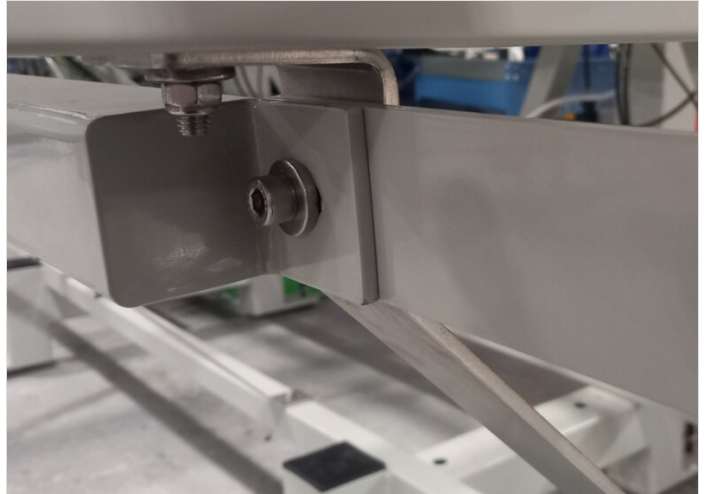

---

Step 11 -

---

