

R0015255 Mount Assemblies to Main Frame

Instructions to mount pre built assemblies to main frame

 Difficulty **Medium**

 Duration **8 hour(s)**

Contents

Introduction

Step 1 - Unless otherwise stated

Step 2 - Mount pre built R0015007 Bench Assemble Roller Tables

Step 3 - Mount pre built R0015004 Bench Assemble Gripper

Step 4 - Mount Energy chain angle brackets Lower

Step 5 - Mount short upper chain angle brackets

Step 6 - Fit lower chain trays

Step 7 - Fit Carriage bracket

Step 8 - Important Information

Step 9 - Quality instance

Step 10 - Attach pre built R0015251 energy chain

Step 11 - Adjust lower trays to suit energy chain

Step 12 - Adjust lower tray height

Step 13 - Quality check

Step 14 - Finalise fixings

Step 15 - Mount Datum flag

Step 16 - Quality Check

Step 17 - Mount R0015096 Bench Assemble Transfer Drive Assembly

Step 18 - Add drive chain.

Comments

Introduction

Tools Required

Standard Hex key set

Standard spanner set

300 mm rule

1000mm rule

Parts Required

D0015291 Datum Flag x 1

D0015717 Energy Chain Angle Bracket Lower x 5

D0015718 Energy Chain Angle Bracket Upper x 5

D0015720 Carriage Bracket x 1

D0015721 Energy Chain Tray Deep Long x 2

D0015722 Energy Chain Tray Shallow Long x 1

D0015861 Energy Chain Cable Support x 1
R0015007 Bench Assemble Roller Tables
R0015096 Bench Assemble Transfer Drive Assembly
R0015251 Bench Assemble X axis components and energy chain
R0015004 Bench Assemble Gripper

Step 1 - Unless otherwise stated

Use loctite 243 on all fasteners

Use Loctite 572 on all threaded pneumatic connections

Pen mark all fasteners to show finalised



Step 2 - Mount pre built R0015007 Bench Assemble Roller Tables

Mount roller beds as indicated , using M8 x 25 socket caps and heavy M8 washers.

Do not apply adhesive to fasteners and only apply holding tension to fasteners

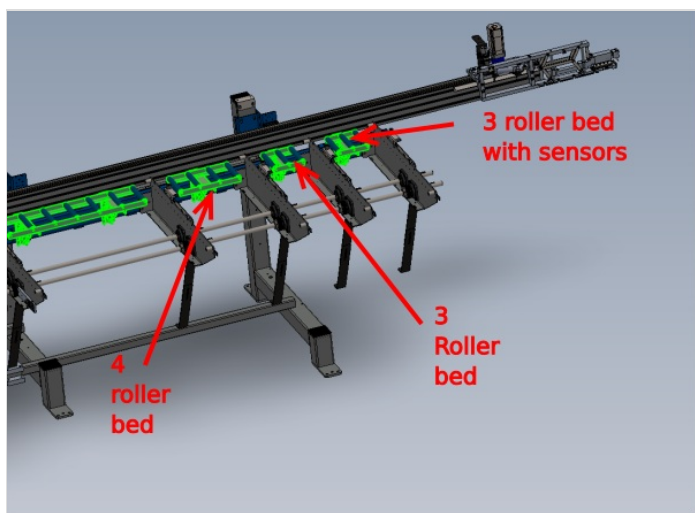
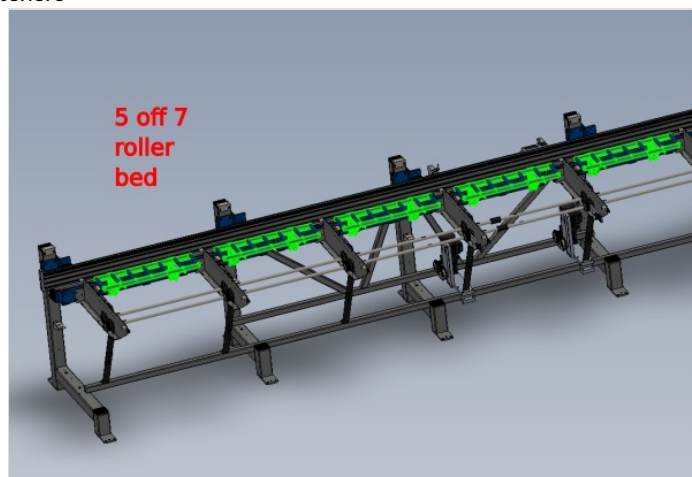
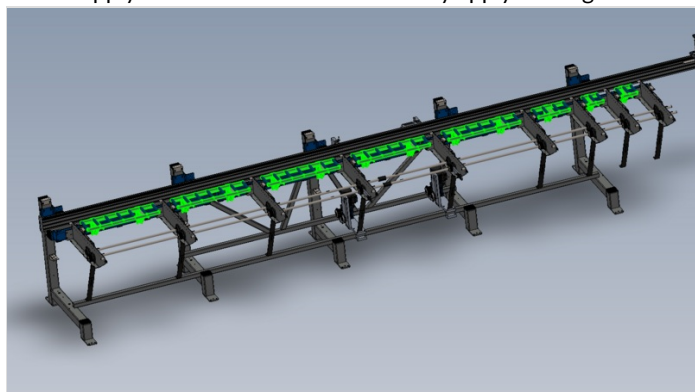

Step 3 - Mount pre built R0015004 Bench Assemble Gripper

1 Mount Gripper assembly to carriage using 2 off M8 x 35 socket caps 2 off M8 x 25 socket caps and heavy M8 washers

2 Check and adjust parallel to ensure gripper is true to hepco beam both indicated measurements should be identical
Tolerance 0.5mm

3 Finalise level of gripper. Use engineers level on indicated face . Manipulate mounting brackets to set level. Finalise fasteners once set
Tolerance 0.5mm

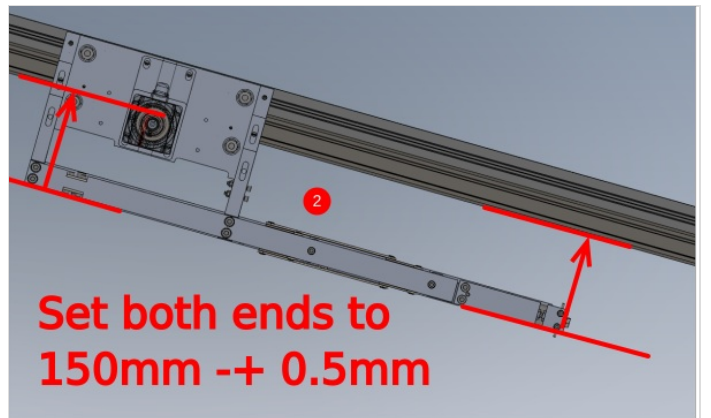
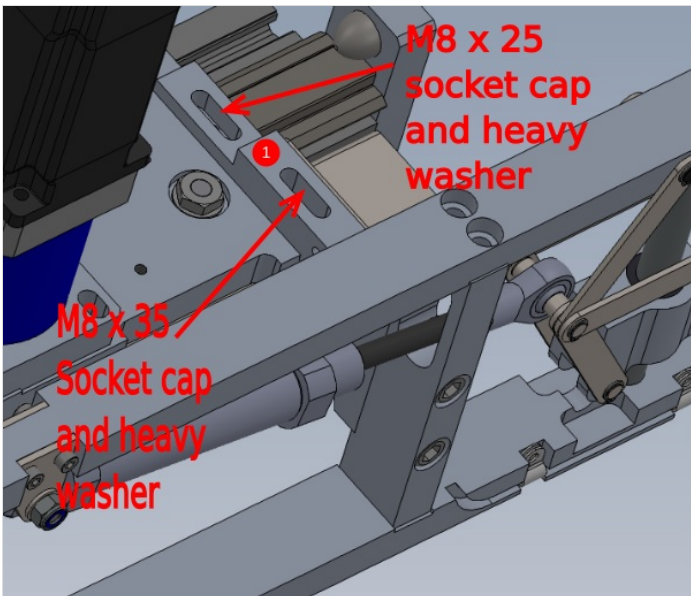
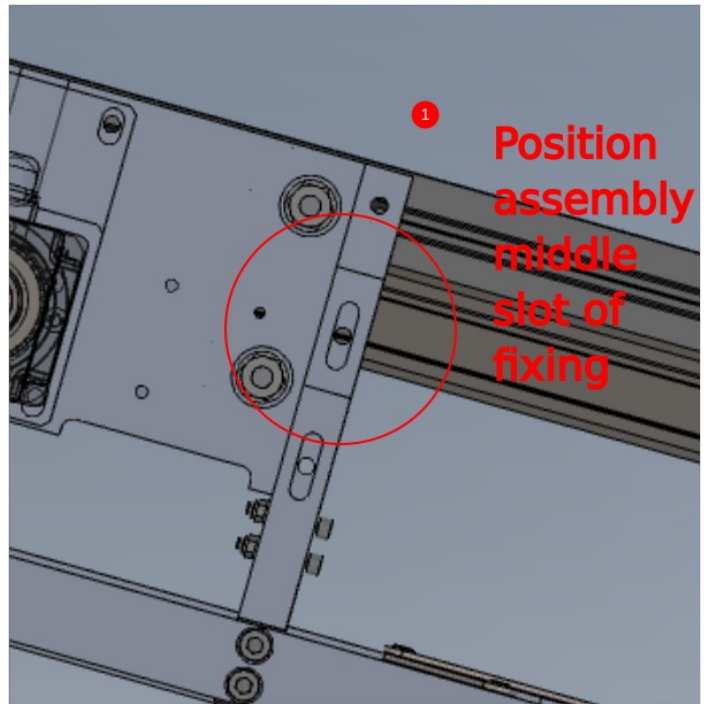
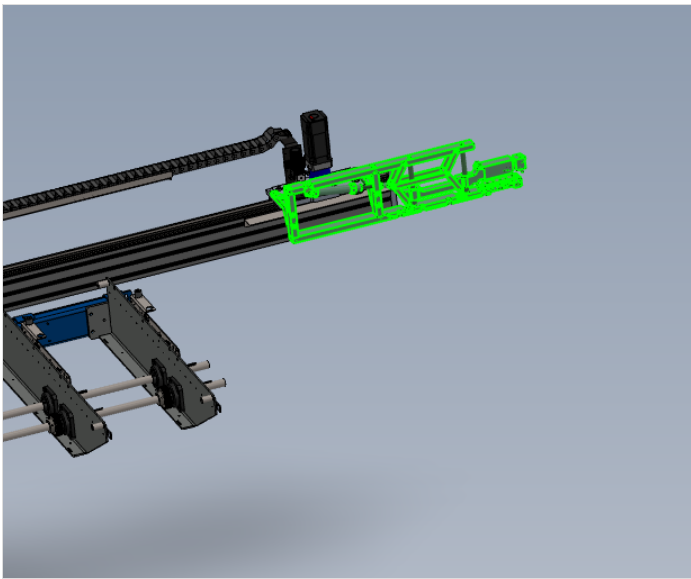

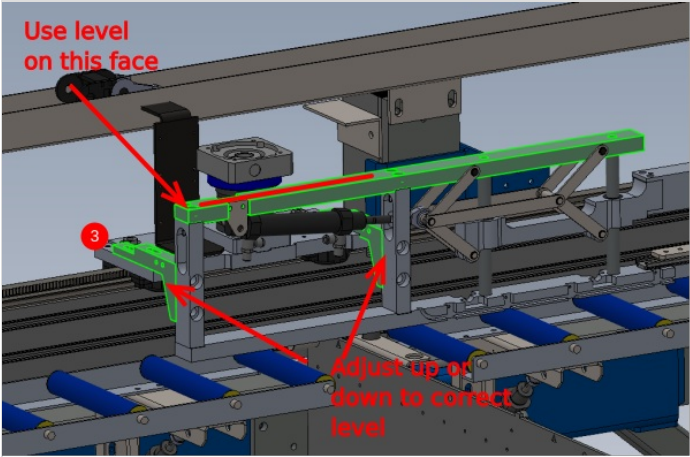

Step 4 - Mount Energy chain angle brackets Lower

1 Mount 5 off D0015717 Lower mounting angle with 2 off M10 x 20 set bolts and A form washers per bracket . Do not apply adhesive at this point

2 Set height to just clear plastic frame cap and set bracket level

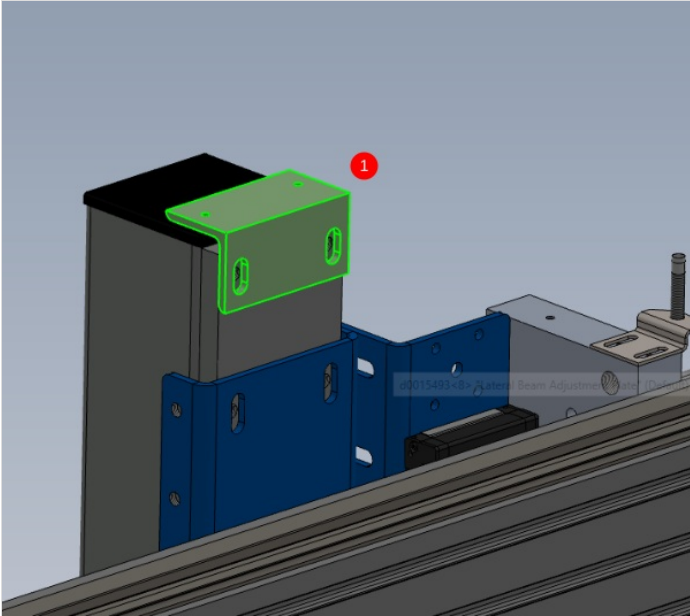
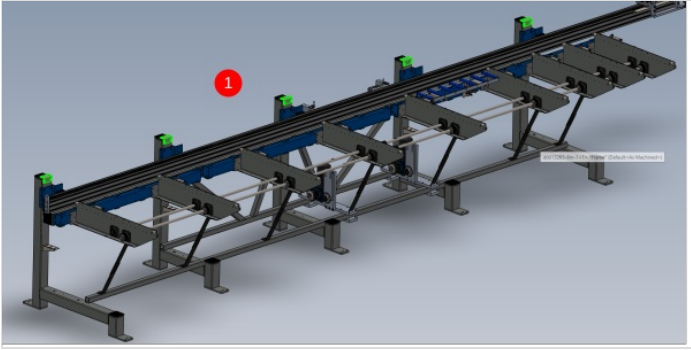

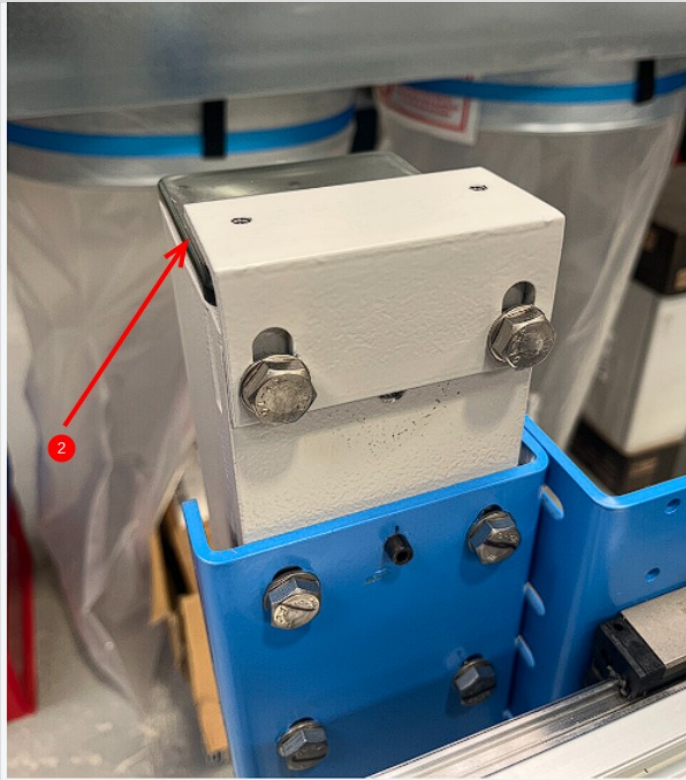

Step 5 - Mount short upper chain angle brackets

1 Mount 3 off D0015718 to indicated point using M6 x 12 socket caps and heavy M6 washers . Set faces flush as with previous step

2 Position 2 off D0015718 at indicated points and use M6 x 16 socket caps and heavy washer to fix in position combining part D0015861 as shown

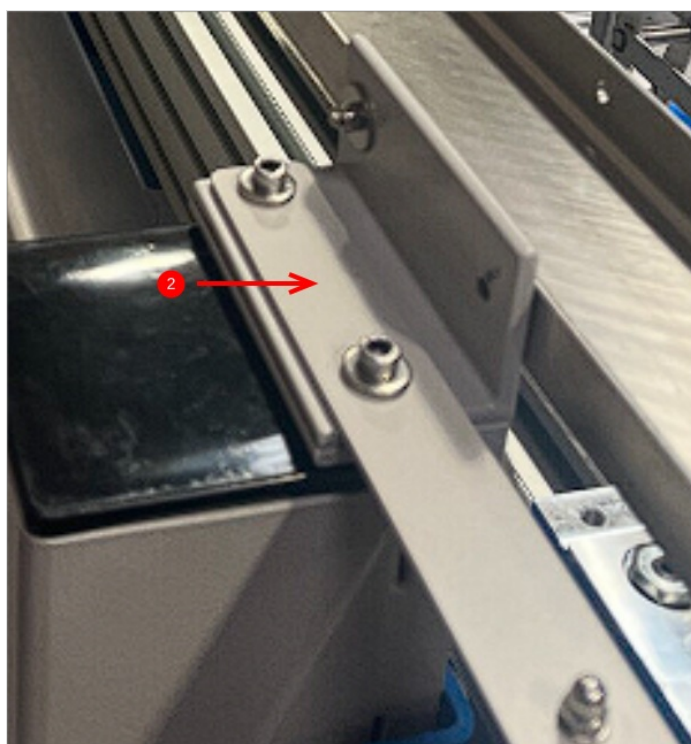
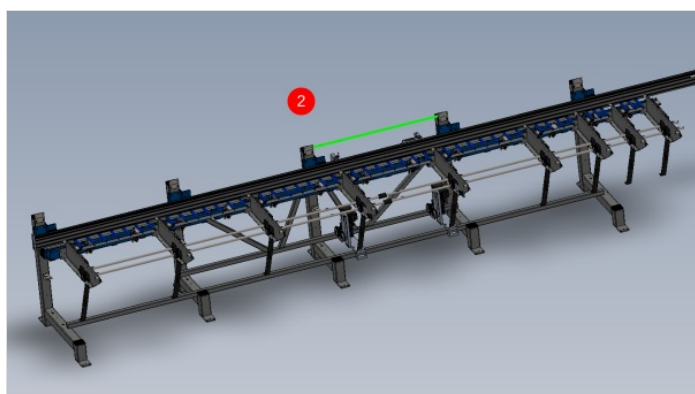
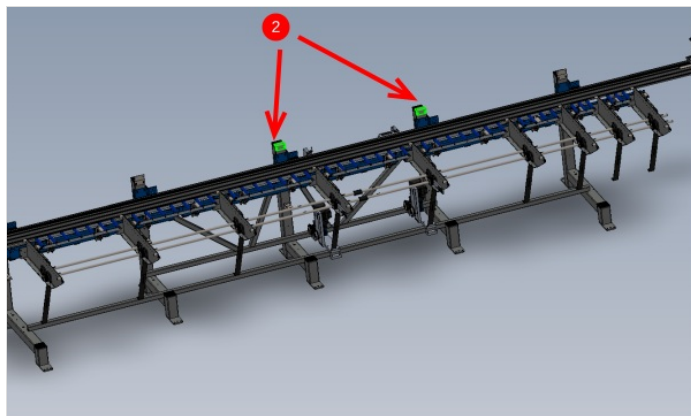
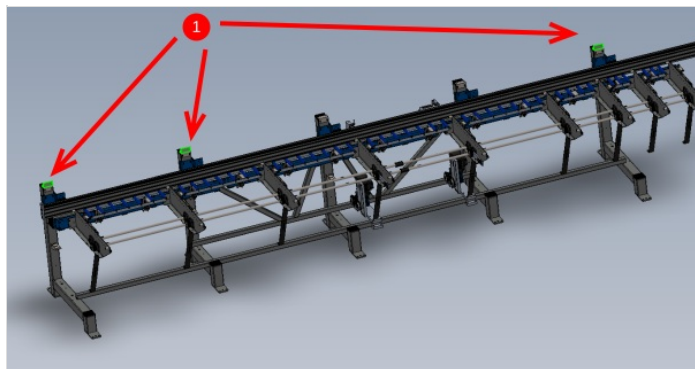

Step 6 - Fit lower chain trays

Lightly fix these parts, as adjustment will be required later

⚠ ...Do not fit washers under the heads of button heads on all fitted energy chain trays

1 Fit D0015722 to indicated point. Use M5 x 16 button hex bolt (This is the correct name for a button head bolt with a hex drive), M5 penny washer and M5 nyloc nut .

2 Fit D0015721 at indicated position with same fixings as above

3 Fit D0015721 to indicated point with same fixings as above

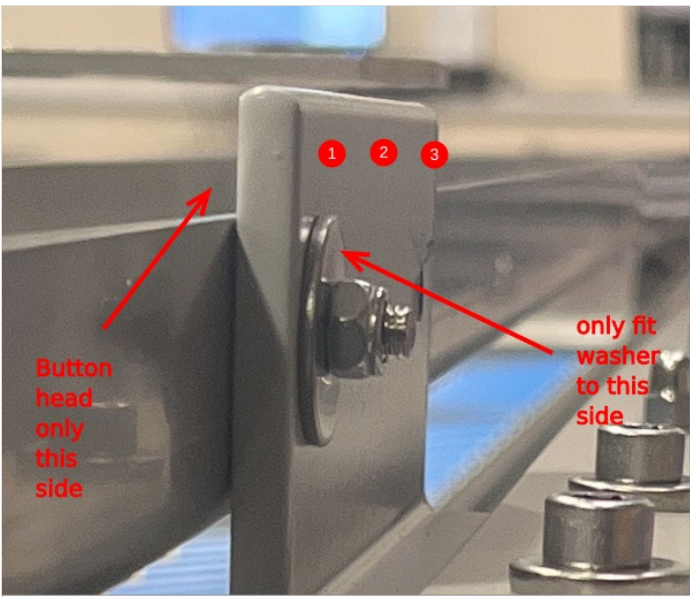
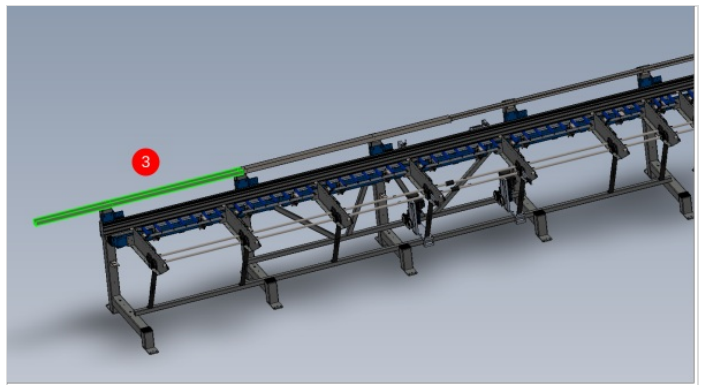
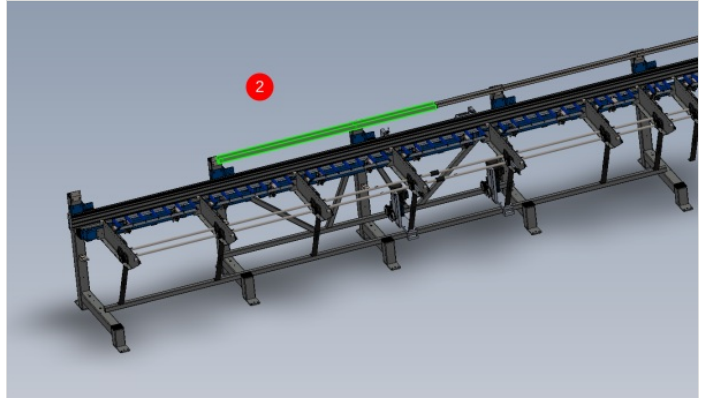
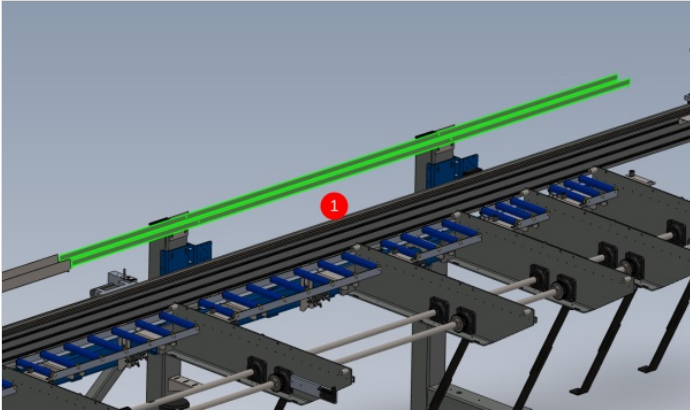

Step 7 - Fit Carriage bracket

Fit D0015720 carriage bracket as shown using M6 x 12 socket caps and A form washers

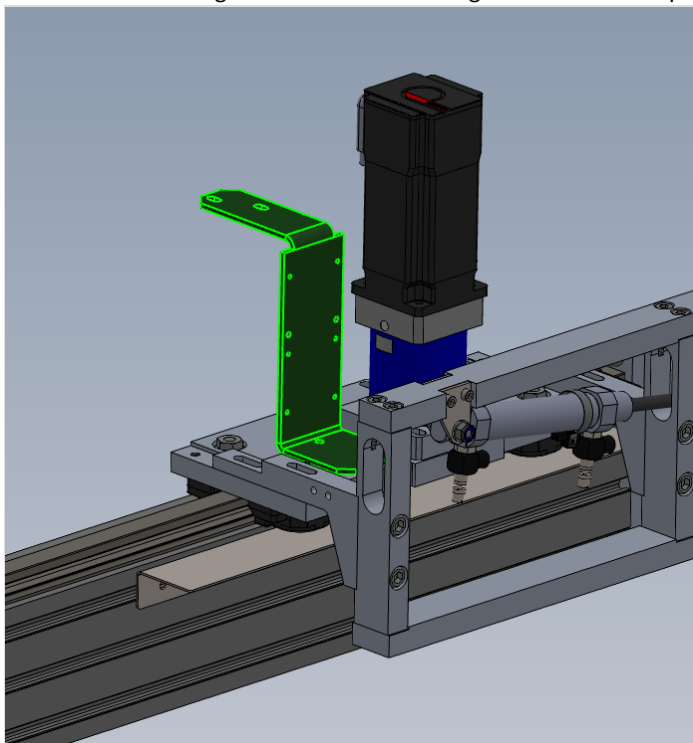

Step 8 - Important Information

Energy chain assembly has 2 different mounting positions
It is VITAL the correct ones are used
Please fit using correct holes. Picture attached shows the energy chain fitted using the WRONG holes for mounting



Step 9 - Quality instance

It is vital the energy chain is correctly aligned to the energy chain trays

From an overhead view, the energy chain must sit directly above and equal within the energy chain trays

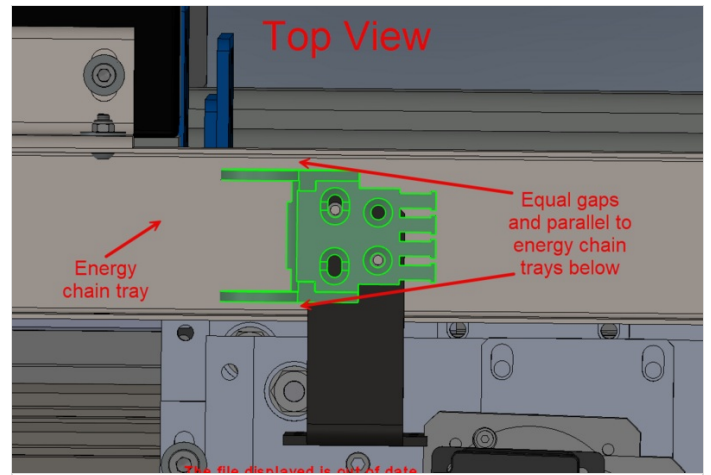

Step 10 - Attach pre built R0015251 energy chain

ECR in progress for updates to energy chain rays . Fixing holes may require drilling to new style until latest revision parts are issued
Fit pre built energy chain from assembly R0015251 and attach using M6 x 16 countersunk hex heads, medium washers and M6 nyloc nuts

⚠ ...Ensure pre assembled energy chain has reversed links fitted to the gripper assembly connection end Ensure energy chain brackets are fixed so the energy chain runs parallel to the trays

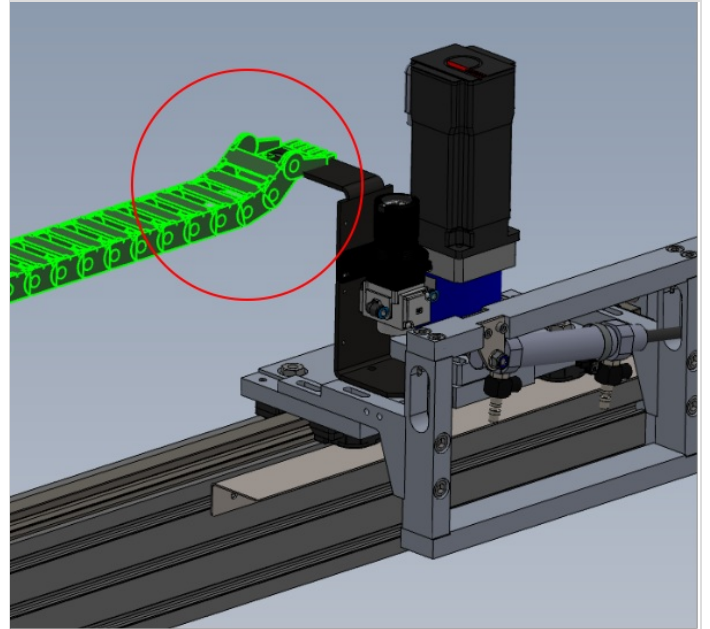
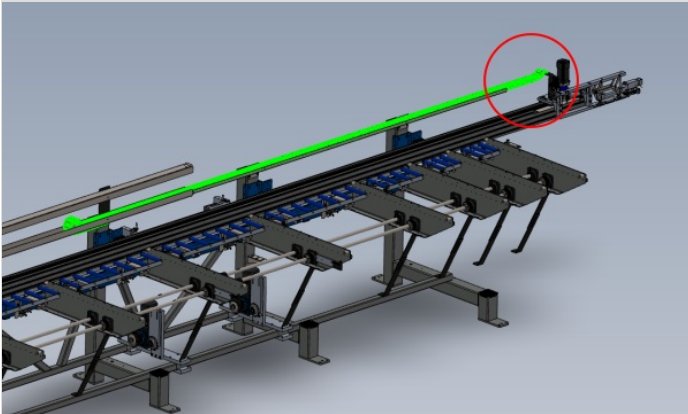

Step 11 - Adjust lower trays to suit energy chain

1 Move gripper with energy chain attached to point indicated

2 Adjust bracket in indicated direction so that energy chain sits central in the tray

3 Measure indicated distance

4 Set the next 4 lower tray mounting points to replicate this measurement using the same method of adjustment with the angled bracket

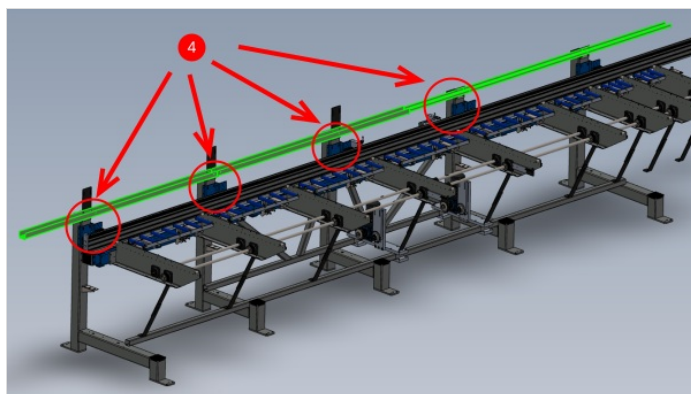
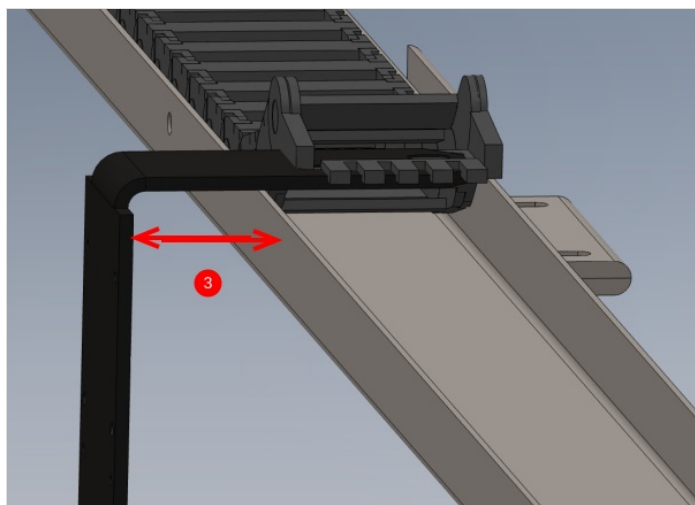
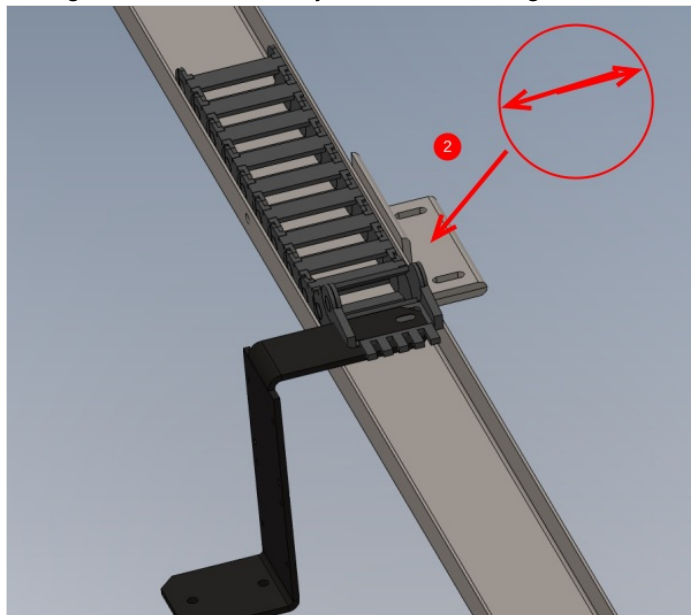
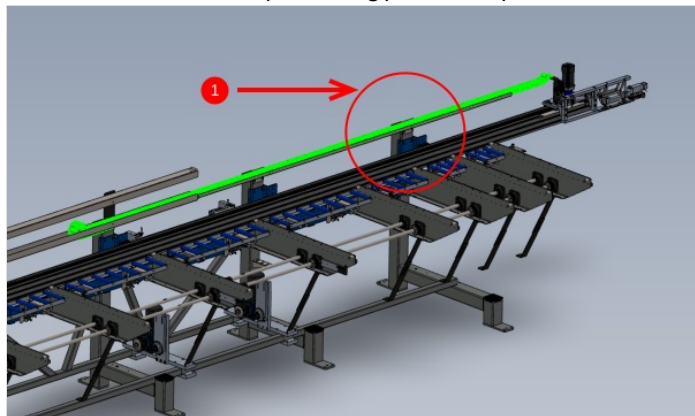

Step 12 - Adjust lower tray height

Using the first point used to set the brackets, measure the gap indicated and replicate this measurement on the other 4 points. This is adjusted by moving the indicated bracket up or down.

i ...If enough adjustment isn't available on remaining positions, first position can be moved up and new measurement taken

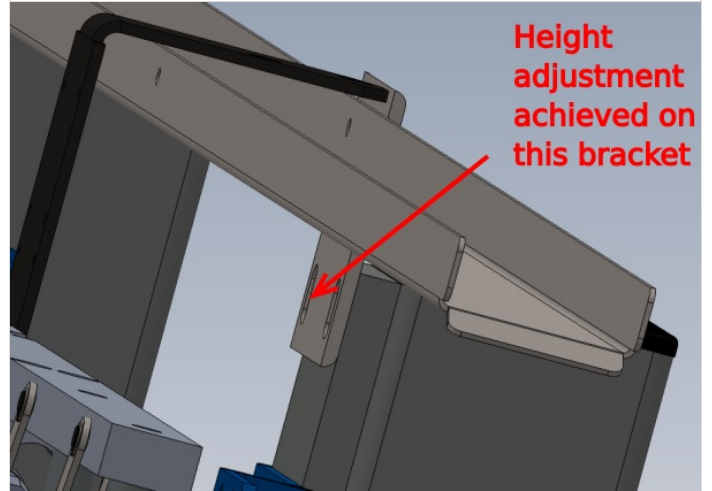
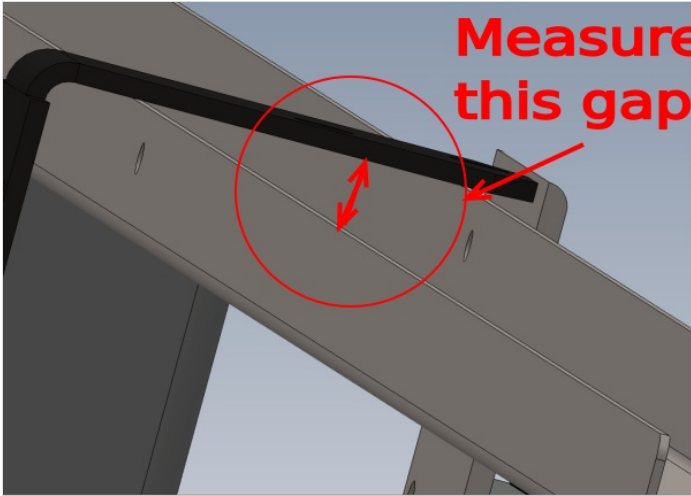

Step 13 - Quality check

Move Gripper carriage along the complete length of the hepco beam, and monitor the energy chain.

Check that there is no sideways pressure on the chain from misalignment

Check that no snags occur on fixings when energy chain is travelling



Step 14 - Finalise fixings

Now aligned, ensure all fixings used to assemble the energy trays and brackets have adhesive applied and final tension added to fasteners and pen marked



Step 15 - Mount Datum flag

1 Mount D0015291 Datum Flag to hepco beam in position shown using 2 off M6 x 12 socket caps , 2 off A form washers and 2 off F0000299 M6 D nuts 2 Adjust Datum sensor at point indicated to be less than 1mm above datum flag face . Use thread and nuts on sensor to adjust height

3 Move gripper to indicated point and adjust datum flag up or down to replicate gap set on previous side

 ...Do not adjust sensor

4 Move gripper back to previous point and check sensor gap is still acceptable

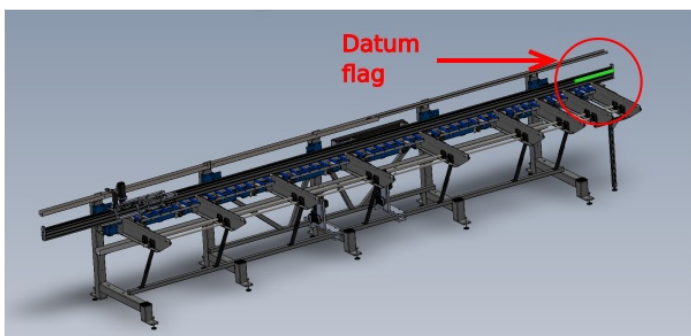
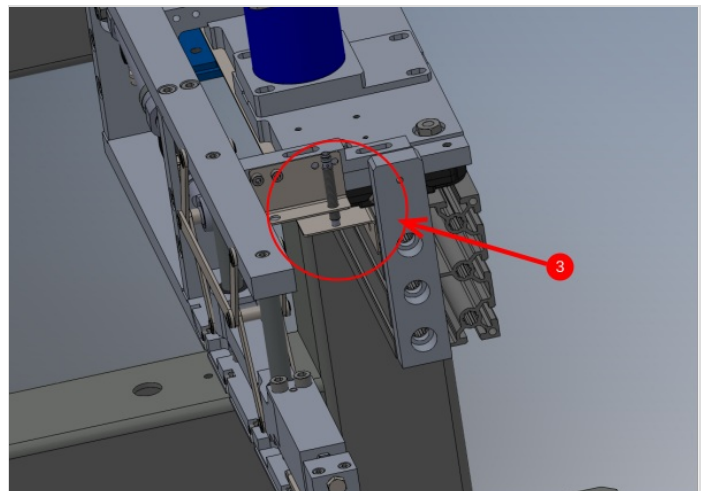
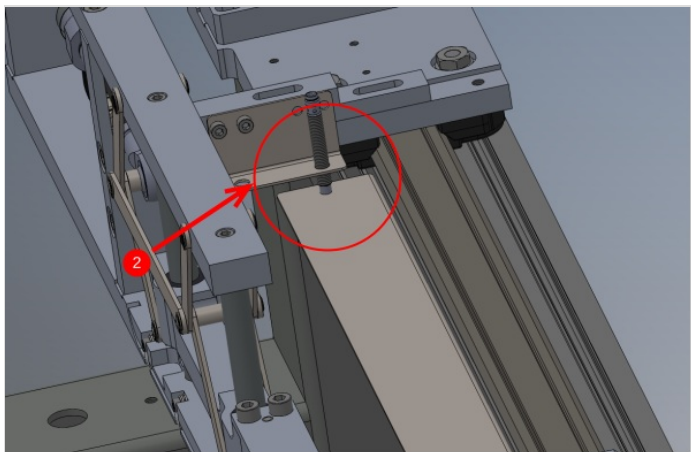
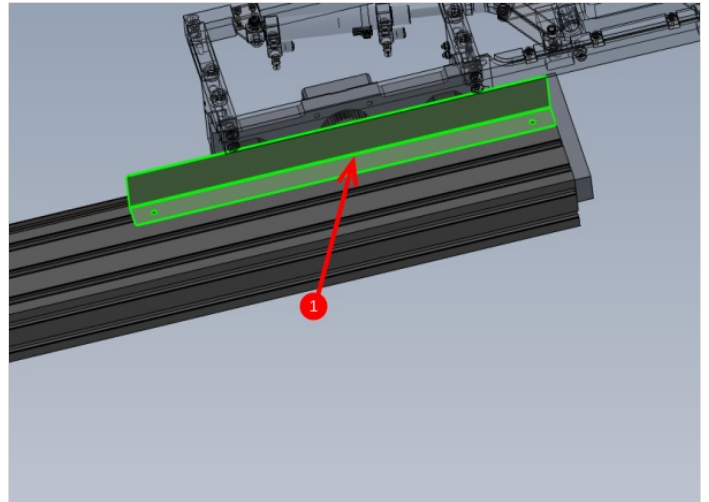
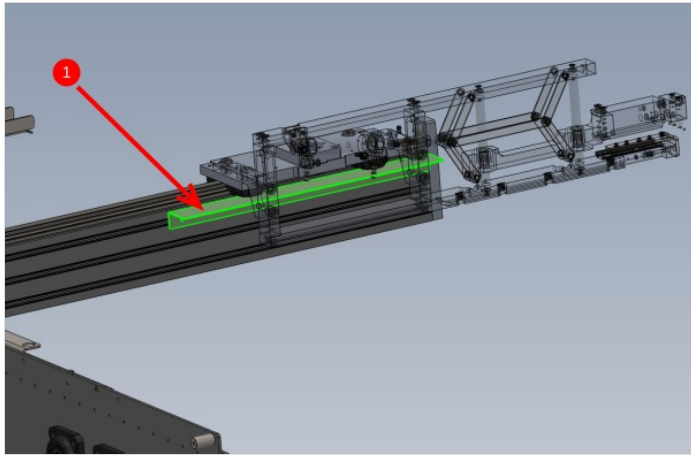

Step 16 - Quality Check

There has been quality instances of the following step and drive chain rubbing in operation

When fitting and aligning chain and drive sprocket for transfer drive motors, please ensure the following is checked when fitting

- Drive chain must not hit or contact any areas when fitted. Clearance must be present in all areas. Please contact supervisor if unsure of correct setting
- Grubscrews that secure drive sprocket must be sufficiently tight and adhesive 243 used



Step 17 - Mount R0015096 Bench Assemble Transfer Drive Assembly

1 Position 2 off drive assemblies in the positions indicated using M12 x 100 set bolts and M12 A form washers

2 Use a 1000mm steel rule to align indicated sprocket with drive sprocket on drive shaft indicated

i ...Sprocket can be moved slightly along shaft but ensure key is always fully engaged into sprocket keyway. Motor assembly can be moved to aid alignment

Repeat for both motor assemblies

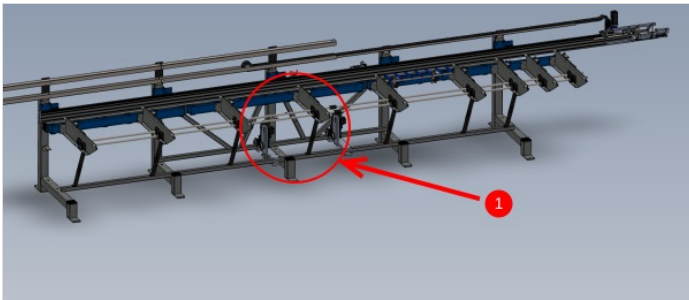

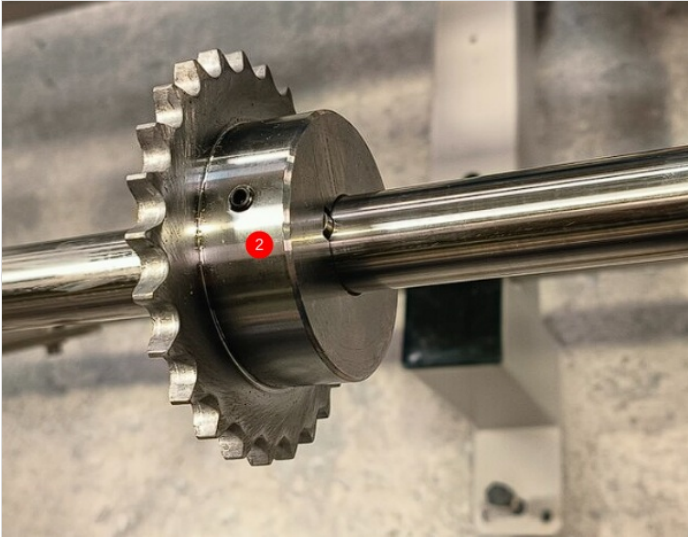
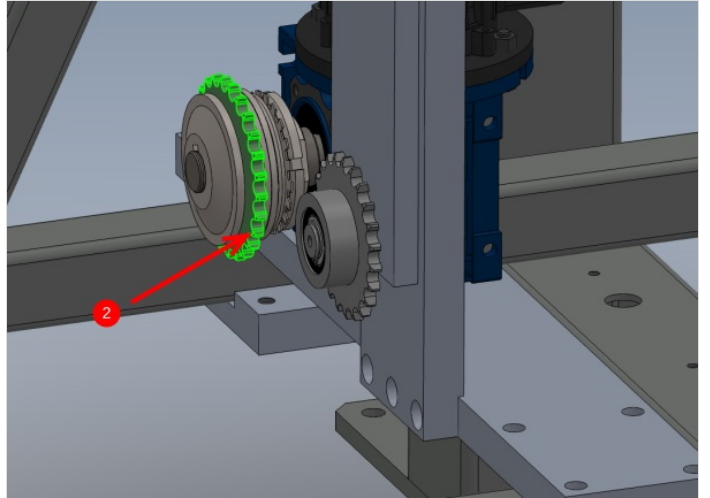
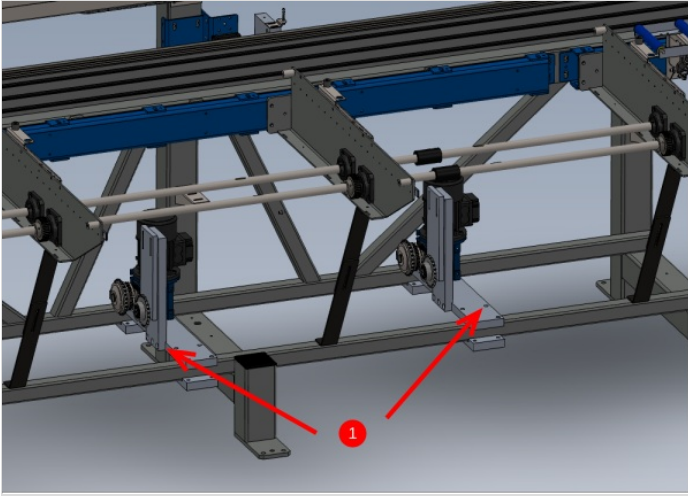

Step 18 - Add drive chain.

1 Fit drive chain to shaft sprocket and motor assembly.

2 Adjust tensioner to apply tension to chain

Repeat for both motor assemblies

