

# R0015252 Bench Assemble Slider units

Instructions to bench assemble slider units

 Difficulty **Medium**

 Duration **2 hour(s)**

## Contents

Introduction

Step 1 - Unless otherwise stated

Step 2 - Warning !!!!

Step 3 - Attach cylinder plate to rack bracket

Step 4 - Attach air fitting

Step 5 - Attach cylinder to bracket

Step 6 - Attach drive rack

Step 7 - Fit concentric Delrin wheels

Step 8 - Fit Eccentric wheels

Comments

## Introduction

### Tools Required

Standard spanner set

Standard hex key set

### Parts Required

D0015551 x 9

D0015255 x 9

D0015549 x 9

P0001111 x 9

P0000010 x 9

B0001160 x 36

B0001161 x 18

B0001162 x 18

## Step 1 - Unless otherwise stated

Use Loctite 243 on all fasteners

Use Loctite 570 on all threaded pneumatic connections

Pen mark all bolts when finalised



---

## Step 2 - Warning !!!!



.....It is vital the correct bolts are used in this assembly M5 x 30 SET bolts must be used, not socket caps

image attached to clarify what a set bolt is



---

## Step 3 - Attach cylinder plate to rack bracket

9 off

1 Attach D0015549

to D0015551 as shown. Use 2 off M6 x 10 socket caps with A form washers

2 Ensure bracket is positioned bottom slot as shown and faces marked are parallel

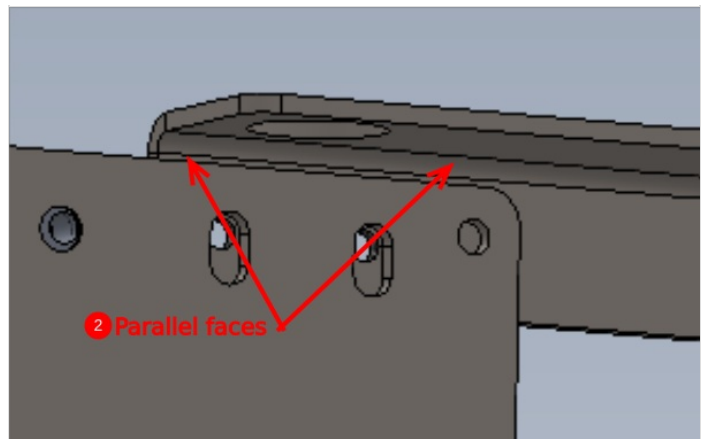
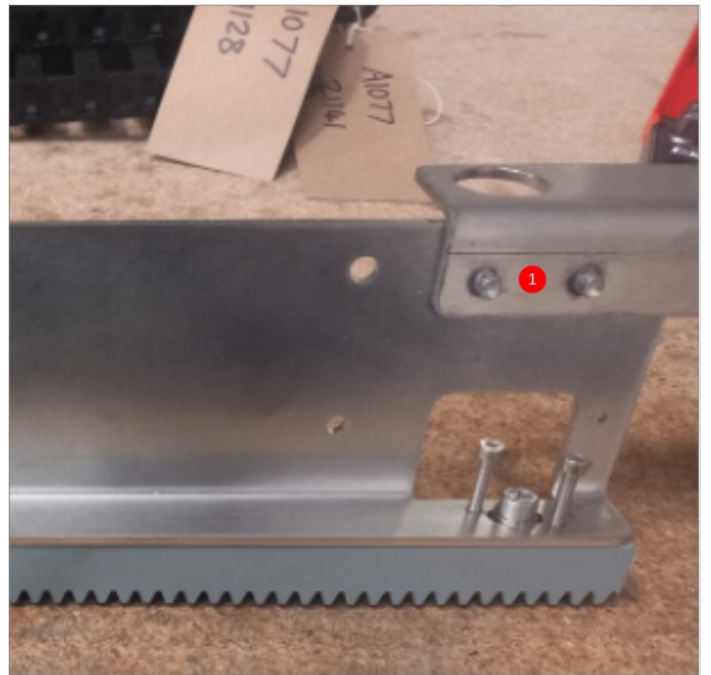

## Step 4 - Attach air fitting

Attach P0000010 elbow fitting to cylinder P0001111 as shown

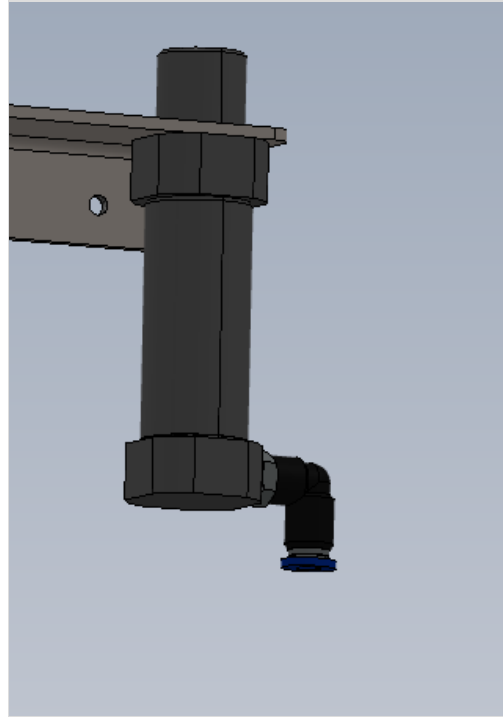

## Step 5 - Attach cylinder to bracket

Mount cylinder to bracket as shown. Loctite 243 should be used on cylinder locking nut

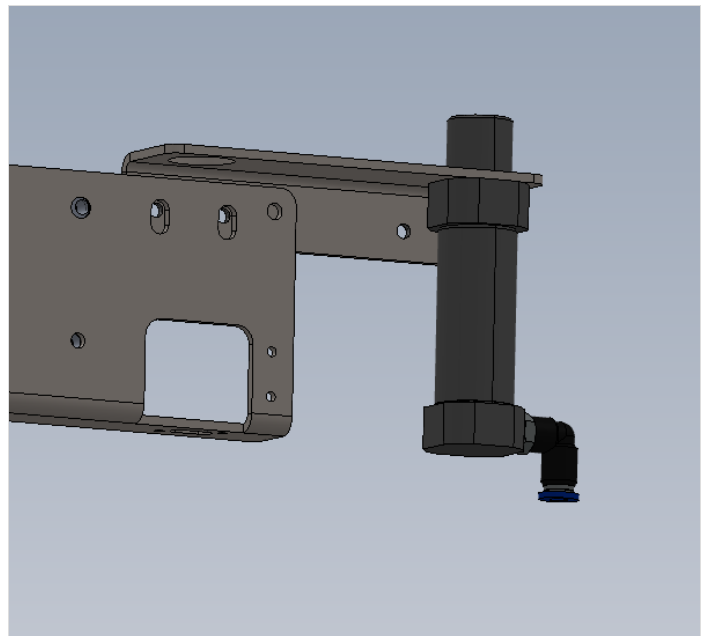

## Step 6 - Attach drive rack

Attach drive rack D0015255 to assembly as shown.

Use m6 x 16 socket caps, M6 A form washers and M4 x 20 socket caps



---

## Step 7 - Fit concentric Delrin wheels

2 off on each assembly

9 off in total

 ...Ensure Set bolts are used

Fit concentric wheels to assembly .

Assemble with in this order

M5 x 30 set bolt- M5 A form washer- Delrin wheel assembly B0001160- spacer B0001161 - Main assembly - A form washer- M5 Nyloc nut



---

## Step 8 - Fit Eccentric wheels

2 off on each assembly

9 off in total

1 Check that part B0001162 sits flush into hole on rack mounting plate. It may be required to remove burrs from manufacture to achieve this

2 Attach delrin wheel in this order.

M5 x 30 Set bolt-M5 A form washer-Delrin Wheel (B0001160) -Eccentric cam(B0001162)- Assembly - M5 A Form Washer- M5 Nyloc nut  
Do not add final tension to this wheel assembly as adjustment will be required at a later point

