

R0015251 Bench Assemble X Axis components and Energy chain

Bench assembly instructions

 Difficulty **Medium**

 Duration **2 hour(s)**

Contents

Introduction

Step 1 - Unless otherwise stated

Step 2 - Assemble energy chain

Step 3 - Add identification to cables and pipes

Step 4 - Add cable sand pipes to energy chain

Comments

Introduction

Tools Required

Pipe cutters
Cable / pipe markers

Parts Required

A0001077 x 5.37
A0001070 x 1
E0000439 x 2
E00001237 x 1

Step 1 - Unless otherwise stated

Use Loctite 243 on all fasteners
Use Loctite 572 on all threaded pneumatic connections
Pen mark all bolts to show finalised



Step 2 - Assemble energy chain

Assemble energy chain using 177 links of A0001077 and 1 set of A0001070

1 Assemble moving end as shown. Ensure the indicated 4 links are rotated 180 degrees to the rest of the links on the energy chain

2 Assembly fixed end as shown

3 Quality check energy chain to make sure all linked are mounted in the correct orientation . Check that the 1st four are opposite and the remaining links are all orientated the same way

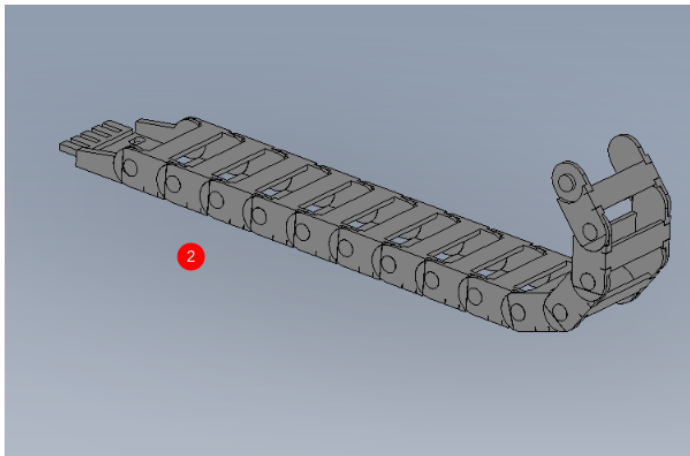
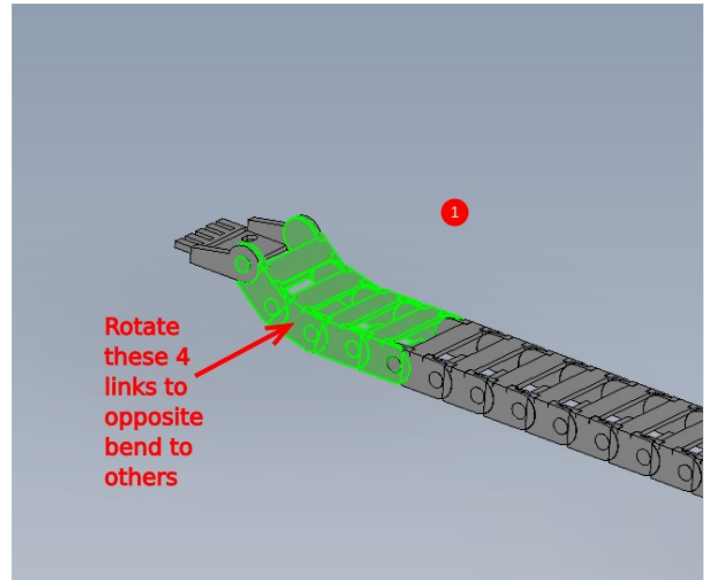
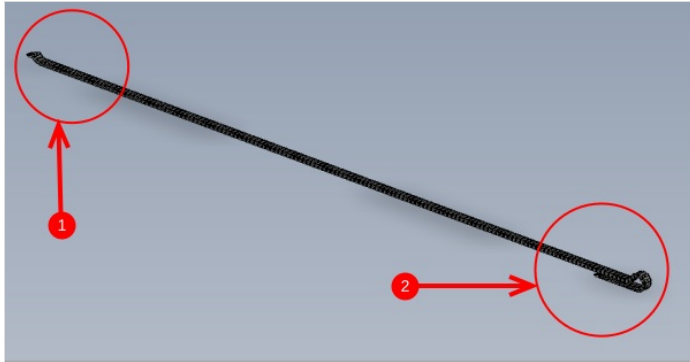

Step 3 - Add identification to cables and pipes

Identify the following with markers

E000439 cable marked as X44

E0000439 cable marked as X283

E0001237 cable marked as X

3 off 6mm black air pipes 11 meters long marked as

- 1229
- 1219
- 1211

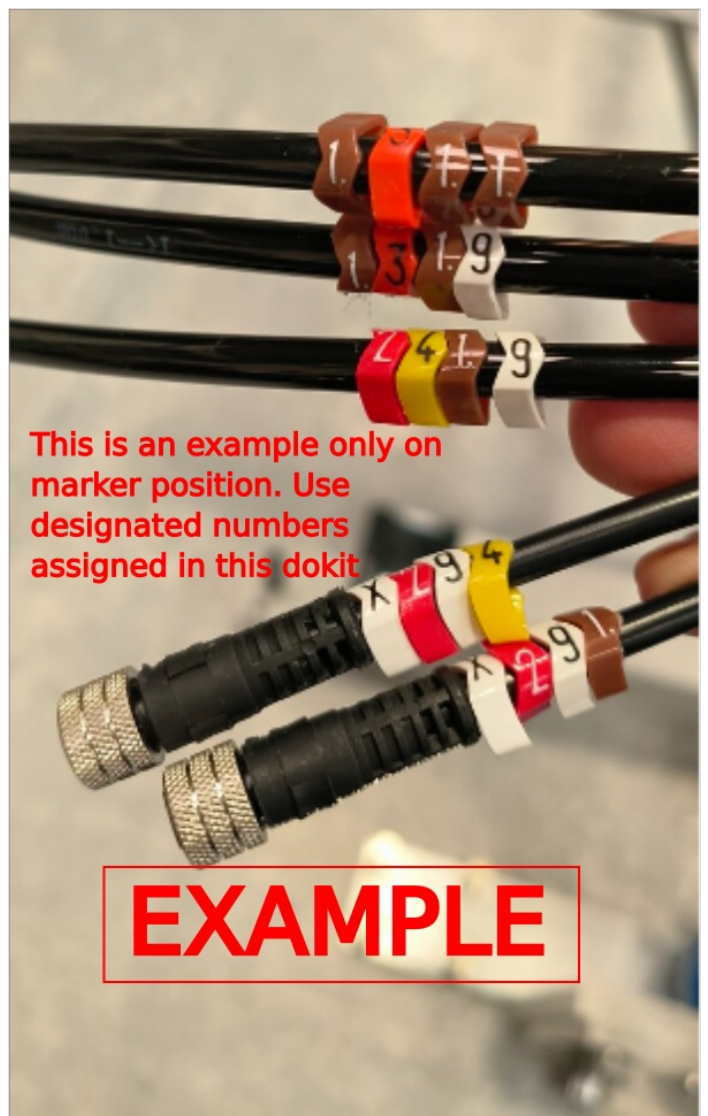

Step 4 - Add cable sand pipes to energy chain

Fit to energy chain ensuring no twists are present . All cables and pipes should run in straight limbs through the energy chain

1 Ensure the two plug ends and main servo end are exiting from the correct end of the energy chain

2 leave approximately 1 meter of pipes and cable exiting the indicated end

