

R0015251B Bench Assemble X Axis Energy chain

Assembly details for X axis energy chain

 Difficulty **Medium**

 Duration **2 hour(s)**

Contents

Introduction

Step 1 - Count links

Step 2 - Assemble links and reverse 2 off

Step 3 - Attach mounting brackets

Step 4 - Fit separators

Step 5 - Fit E0000439 Cables

Step 6 - Fit E0001237 servo cable

Step 7 - Fit air pipes

Comments

Introduction

Tools Required

Small flat screwdriver
Identification markers

Parts Required

A0001112 Energy Chain Separator: 2500 Chain x 24
A0001113 Energy Chain: Series 2500.03 55mm Bend Radius x 4.2 meter
A0001114 Energy Chain Bracket Set: 24/2500 Plastic, Pivoting x 1
E0000439 Connector Brad Harrison M8 3 pole 10 m lead pvc x 3
E0001237 Pre Made Cable :Beckoff Extension AM8032 9.0m x 1

Step 1 - Count links

Total links of for A0001113 Energy Chain is 113

Double check correct quantity, But do not assemble links yet

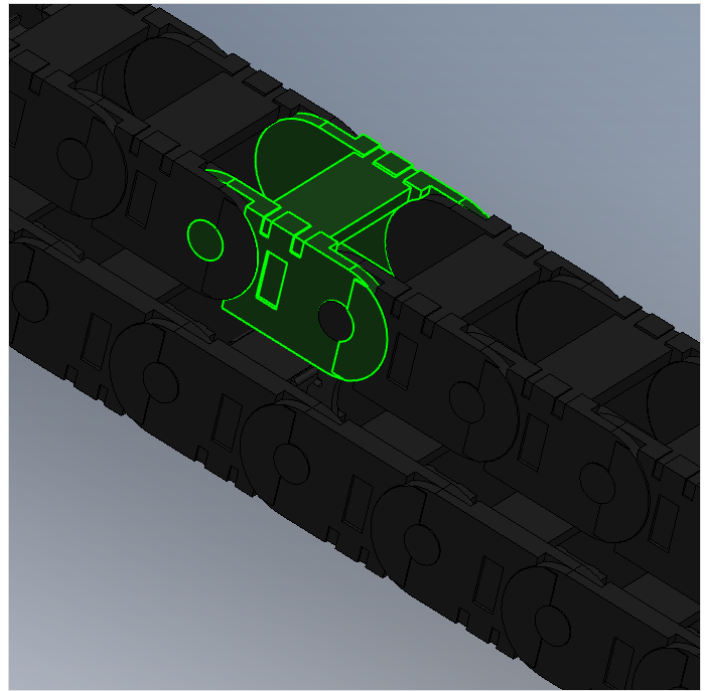

Step 2 - Assemble links and reverse 2 off

1 Assemble 111 links together , ensure all links are orientated the same way .

2 Identify the female end of the assembled links

3 Fit 2 more links of A0001113, but fit in a reversed orientation

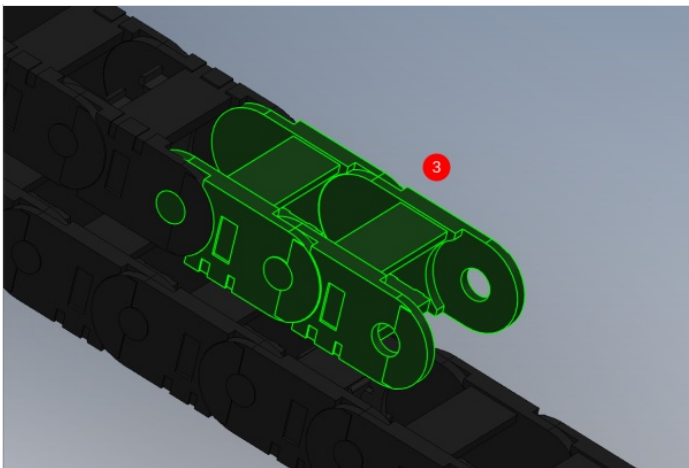
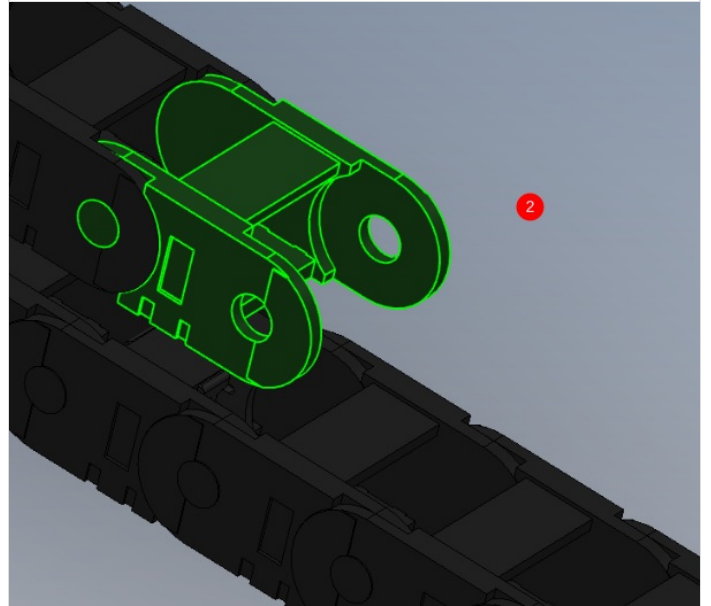
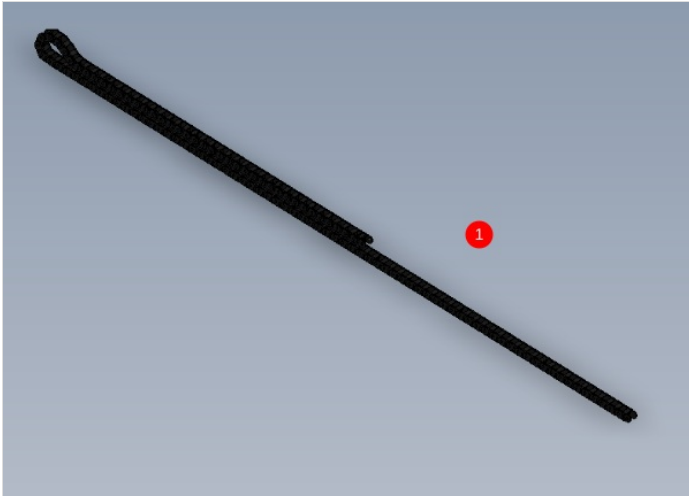

Step 3 - Attach mounting brackets

Attach mounting brackets A0001114

1 Attach male bracket to reversed links and orientated as shown

2 Attach female bracket to opposite end orientated as shown

3 Energy ends will now be itemised as A and B as shown

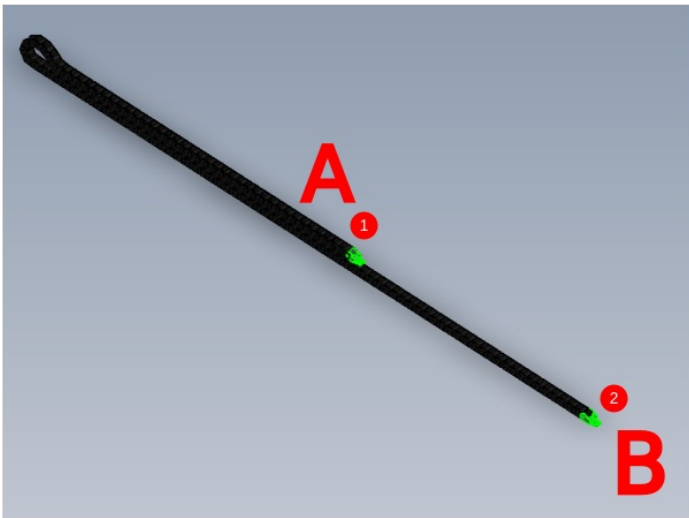
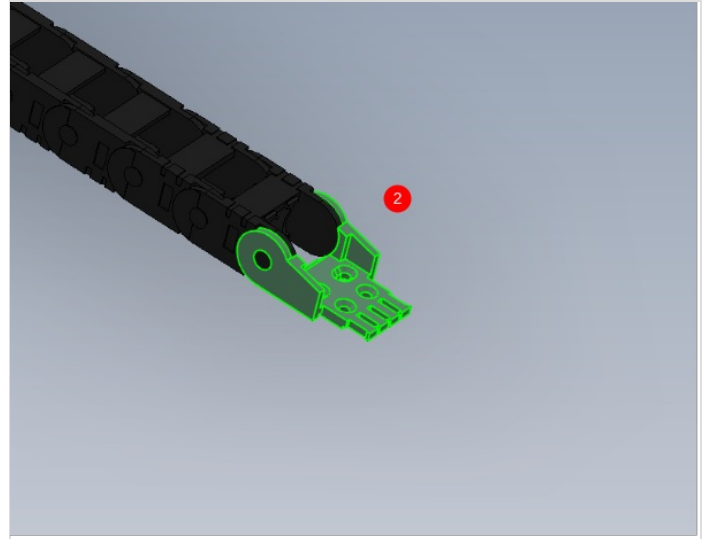
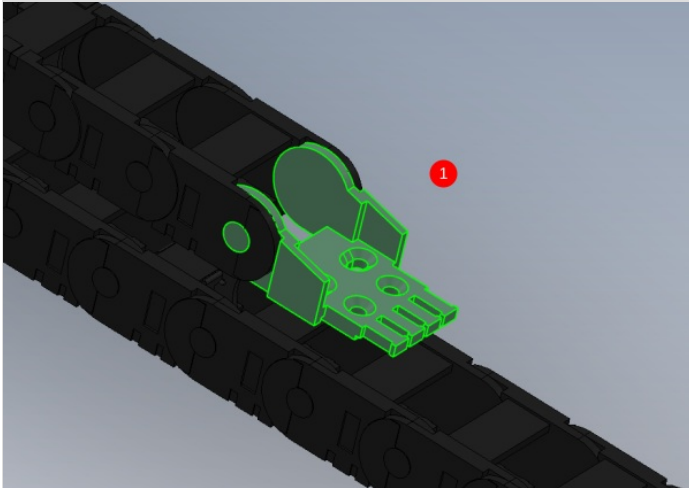

Step 4 - Fit separators

1 Open all links of trunking using a small flat screwdriver to release
Picture required please :)

2 Fit A0001112 Energy Chain Separators to the following positions

Start From reversed link end A , fit 2 separators to first reversed link

3 Counting from the first separators fitted, fit additional 2 off separators to every tenth link

4 This is correct

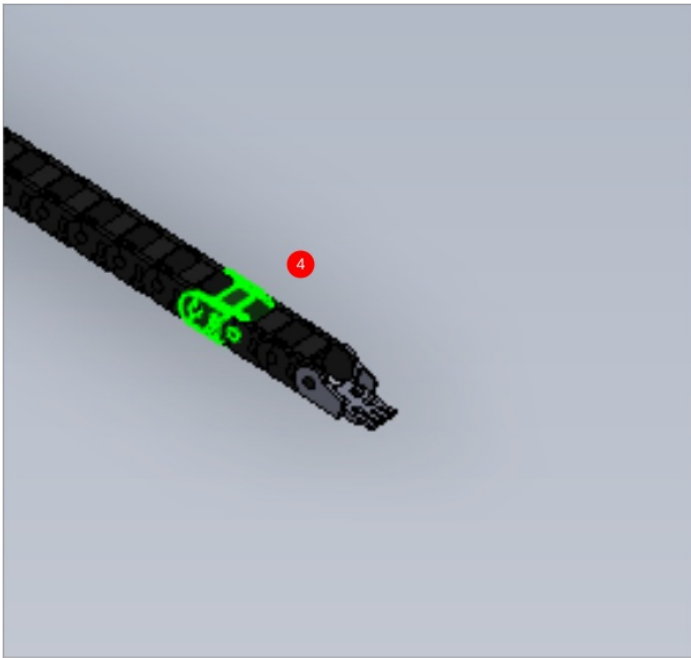
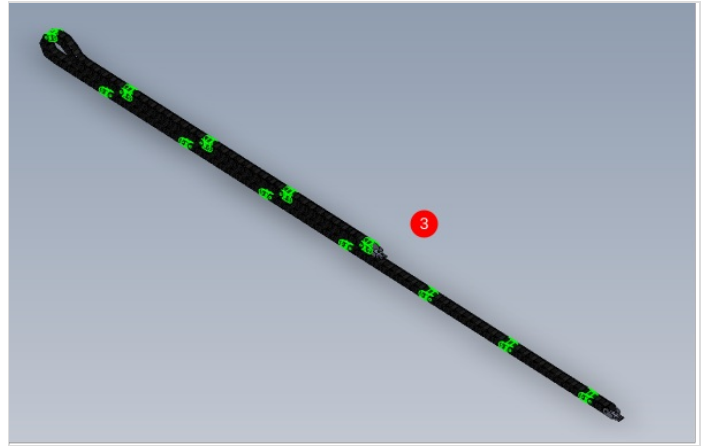
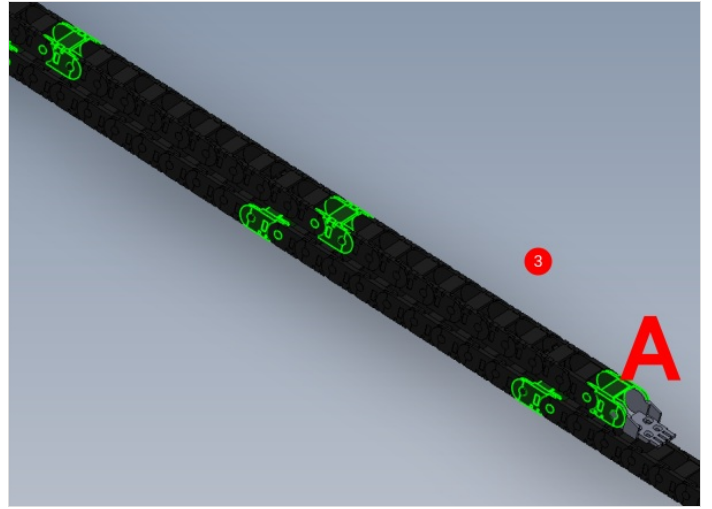
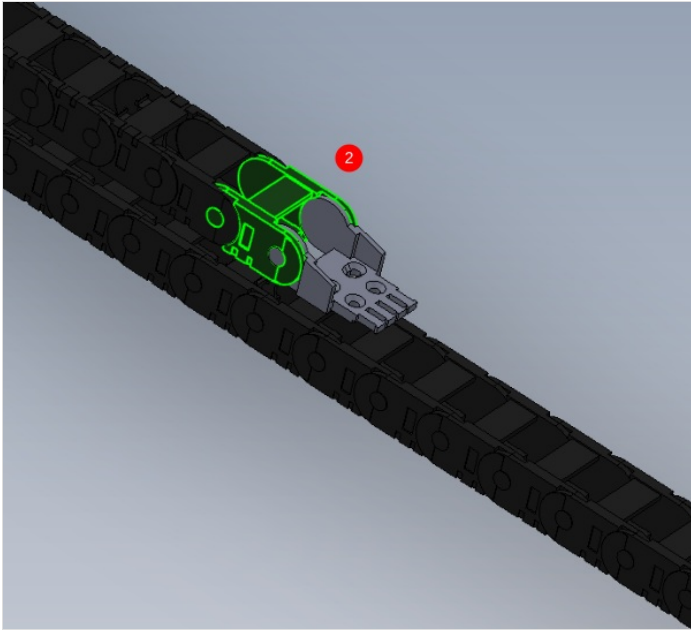

Step 5 - Fit E0000439 Cables

Add identification markers to 3 off E0000439 cables

X44
X283
X10

Fit cables to energy chain in section 1 as shown. Plugs should exit energy chain at the male bracket / reversed link end . Leave 360mm from end of energy chain to the end of the female plugs.

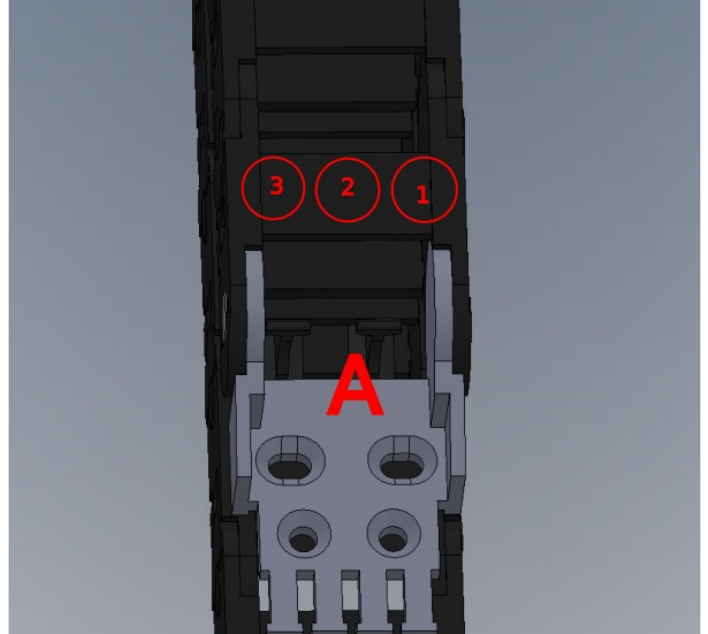
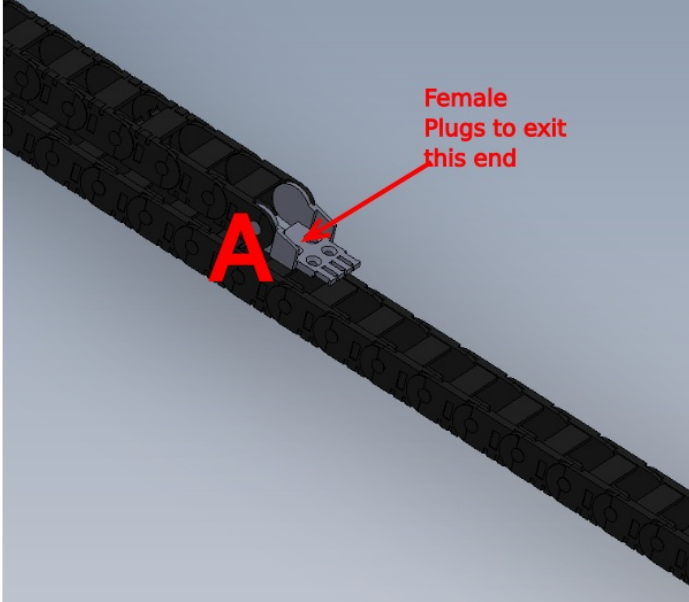

Step 6 - Fit E0001237 servo cable

Use Cable E0001237 Pre Made Cable :Beckoff Extension AM8032 9.0m x 1 and identify as 'XA'

Fit to section 2 and leave Female plug and 0.5meter of cable to exit energy chain at end A

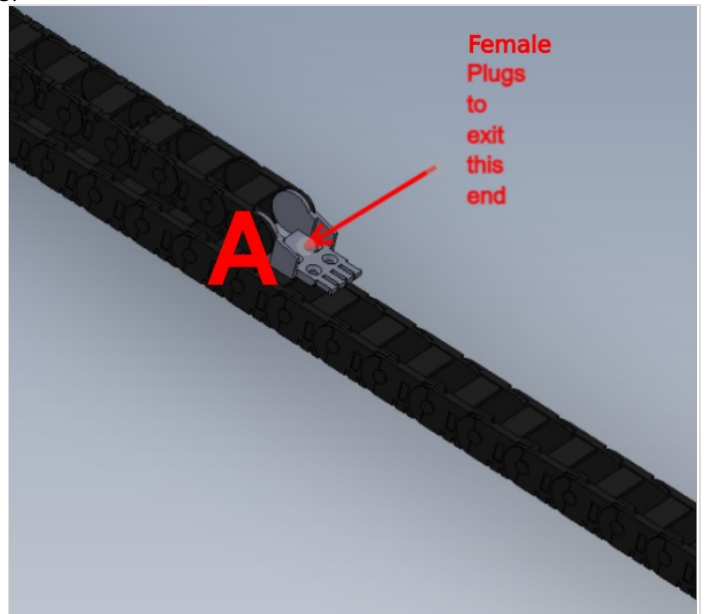
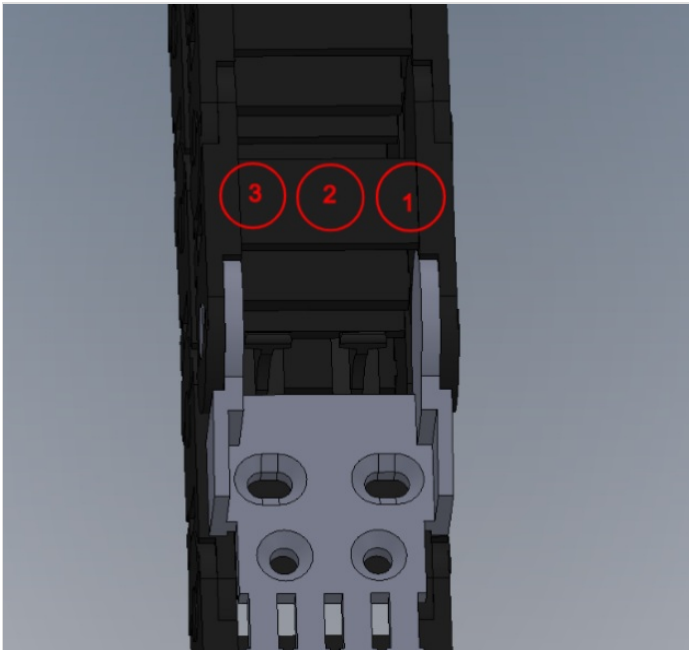

Step 7 - Fit air pipes

Cut 3 Off lengths of 6mm x 4mm black air pipe at 9 meters

Add identification as follows

1229

1211

1219

Fit to section 3 and leave 1 meter of pipe exiting the energy chain at end A

