

# R0015249 Set drive pinions in position

Instructions to correctly set drive pinions into positions on shafts

 Difficulty **Medium**

 Duration **1 hour(s)**

## Contents

Introduction

Step 1 - Unless otherwise stated

Step 2 - Set shaft position

Step 3 - Lock shaft position

Step 4 - Set pinion position

Step 5 - Lock Pinion

Comments

## Introduction

### Tools Required

Standard Hex key set

### Parts Required

none

## Step 1 - Unless otherwise stated

Use Loctite 243 on all fasteners

Use Loctite 572 on all threaded pneumatic connections

Pen mark all fasteners to show finalised



## Step 2 - Set shaft position

- Each pair of shafts that are joined together can be moved in the directions show to give the optimal contact on keys and drive pinions
- Take all 9 arm positions into consideration and position each shaft accordingly to achieve the best overall position to suit all arms
- Pinion lock points should always be above keyways

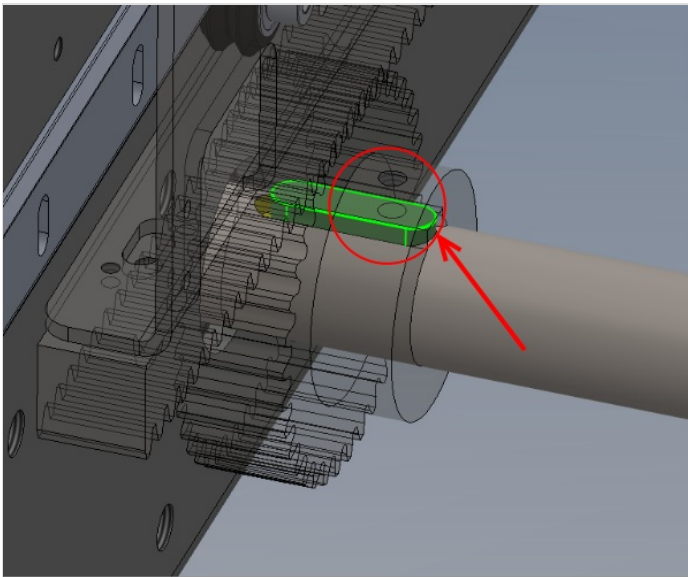
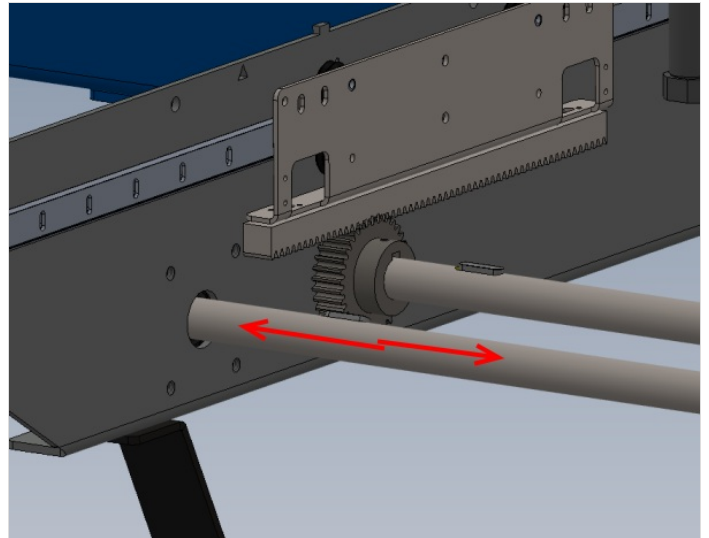
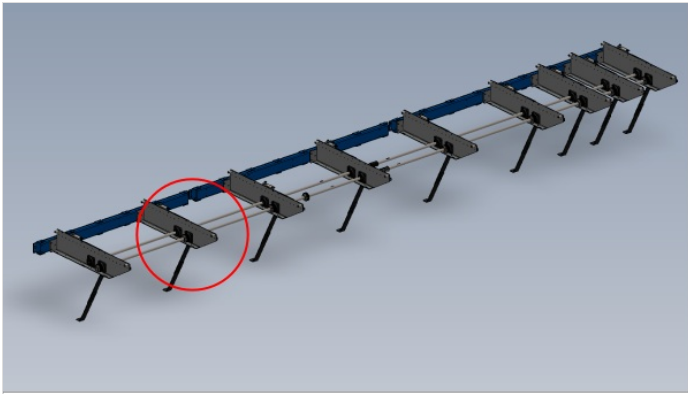

## Step 3 - Lock shaft position

Individually remove and apply Loctite 243 to all grub screws on spherical bearings.

2 off grub screw per bearing

18 off bearing

36 off grub screw in total

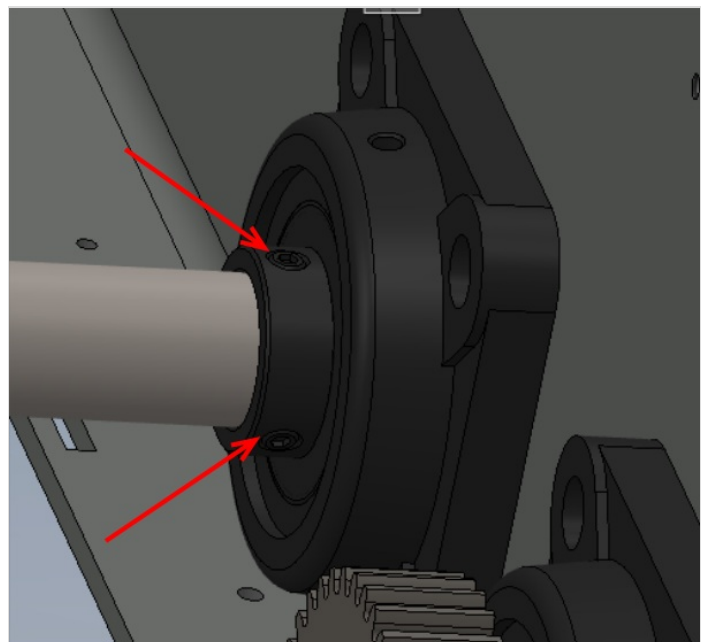

---

## Step 4 - Set pinion position

9 off pinions can now be set in position and finalised  
Set position of pinion to achieve as much contact as possible with drive rail, without contacting side of support arm

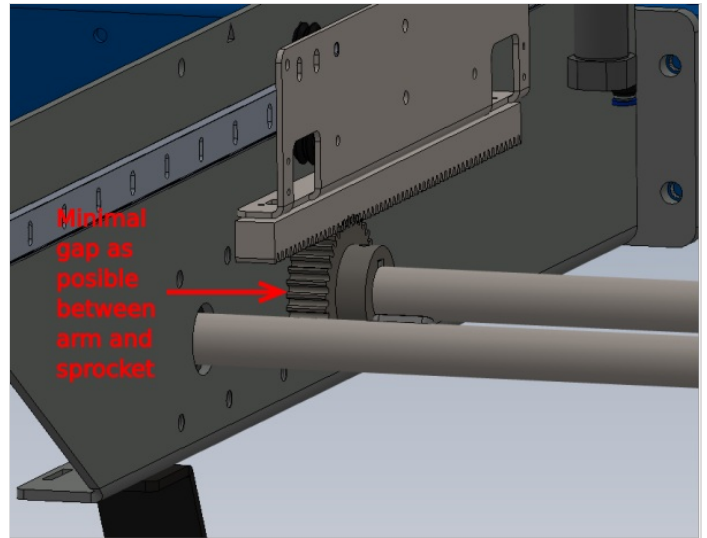

---

## Step 5 - Lock Pinion

lock each pinion in position as follows.

M6 x 10 kcp Grubscrew in hole that contacts key on shaft

M6 x 10 flat bottomed grubscrew on fixing hole that contacts directly onto shaft

