

R0015246 Fit Hepco Drive Beam Cylinder

Instructions to mount and set hepco drive beam cylinder assembly

 Difficulty **Medium**

 Duration **3 hour(s)**

Contents

Introduction

Step 1 - Unless otherwise stated

Step 2 - Add dowels

Step 3 - Assemble drive adapter

Step 4 - Attach Air fittings to cylinder

Step 5 - Fit mounting brackets

Step 6 - Attach mounting angles

Step 7 - Fit cylinder assembly to frame

Step 8 - Check hepco position

Step 9 - Position cylinder stroke

Step 10 - Attach cylinder to beam,

Step 11 - Attach second cylinder mounting bracket

Step 12 - Check Movement

Step 13 - Finalise fasteners

Step 14 - Add hard stops and dampers

Step 15 - Set cylinder stroke hard stops

Step 16 - Set damper position

Step 17 - Quality check

Step 18 - Attach sensors and brackets

Step 19 - Fit cover

Comments

Introduction

Tools Required

Standard hex key set
Ball peen hammer
Standard spanner set

Parts Required

D0015074 Cylinder Support x 2
D0015075 Cylinder Bracket x 4
D0015077B Cylinder Drive Adapter x 1
D0015144 Datum Switch Bracket x 2
D0015948 ZX5 Beam Move Cylinder Guard x 1
E0000336 Sensor: M8; 2mm, PNP N/O, M8 conn x 2
P0000109 RB Series Shock Absorber x 2

P0001118 cylinder 50 x 700 rodless x 1
P0001145 Fitting smc flow controller elbow 10-1/4 bsp
F0000315 D nut M8 x 4

Step 1 - Unless otherwise stated

All bolts to have Loctite 243 adhesive applied unless otherwise stated

All Threaded Pneumatic connections to have Loctite 570 applied

All bolts to be pen marked once adhesive applied and correct tension added



Step 2 - Add dowels

Add 4 off 8mm x 24mm dowels to parts D0015708 as shown



Step 3 - Assemble drive adapter

Assemble D0015077b with contains D0015707 x 1 and D0015708 x 2 using M8 x 30 socket caps 4 off

- REMOVE ALL BURRS AND SHARP EDGES - - DO NOT SCALE - - IF IN DOUBT, ASK -

ITEM	PART No.	DESCRIPTION	QTY.
1	D0015707	Cylinder Drive Adaptor Backplate	1
2	D0015708	Cylinder Drive Adapter Wing	2

Stuga
MACHINERY LTD

Cylinder Drive Adapter

1. Tolerances: Unless Stated: General unless otherwise stated
2. Tolerances: Decoded Places ± 0.1 mm, 0.05 ± 0.1 mm, 0.00 ± 0.05
3. Remove all burrs and sharp edges
4. If in Doubt Ask

See Part Notes

MH 13/01/2020

1.85 kg

D0015077B 1

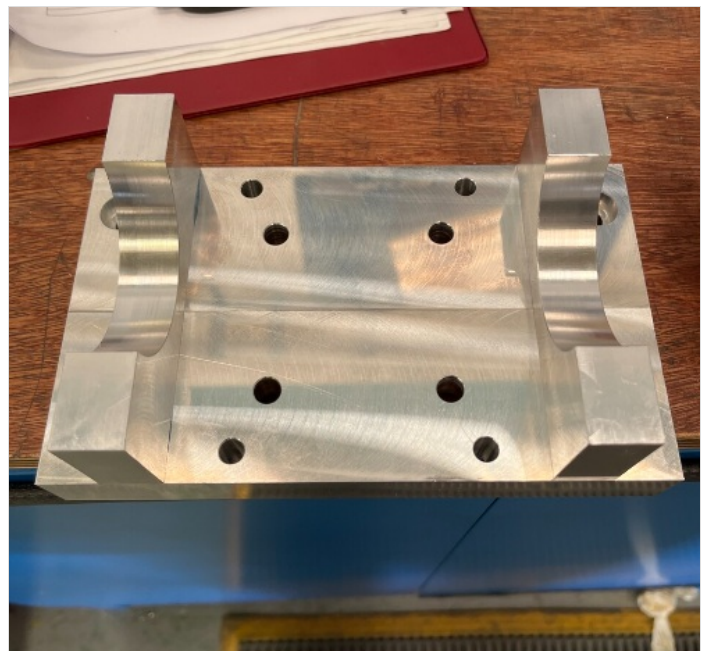

Step 4 - Attach Air fittings to cylinder

Fit 2 off P0001145 air fittings to cylinder P0001118



Step 5 - Fit mounting brackets

1 Mount D0015074 2 off brackets using 8 off M8 x 50 socket caps and M8 a form washers , orientating cylinder as shown

2 Mount D0015077 to cylinder using 4 off M8 x 30 socket caps

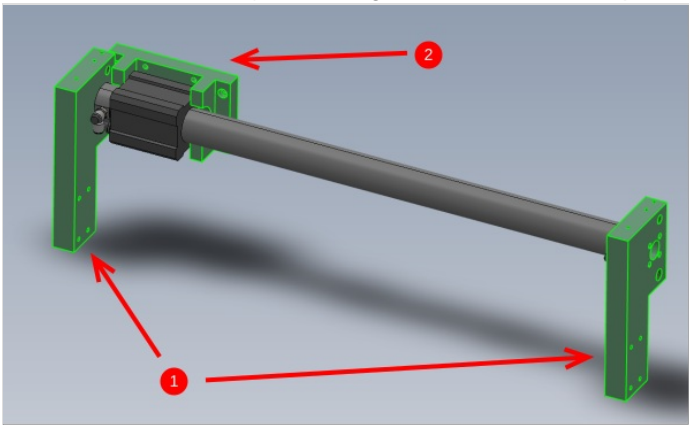

Step 6 - Attach mounting angles

Attach 4 off D0015075 to frame using M8 x 25 bolts and Heavy M8 washers as shown

Do not apply adhesive

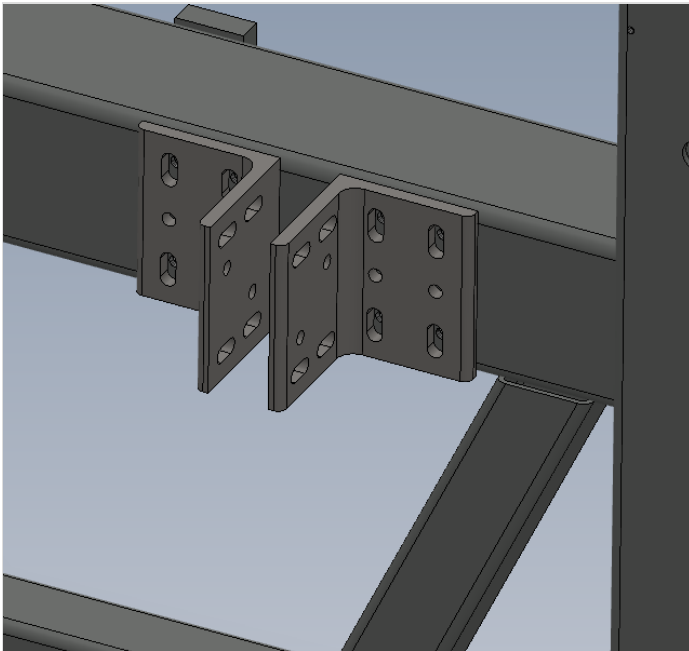
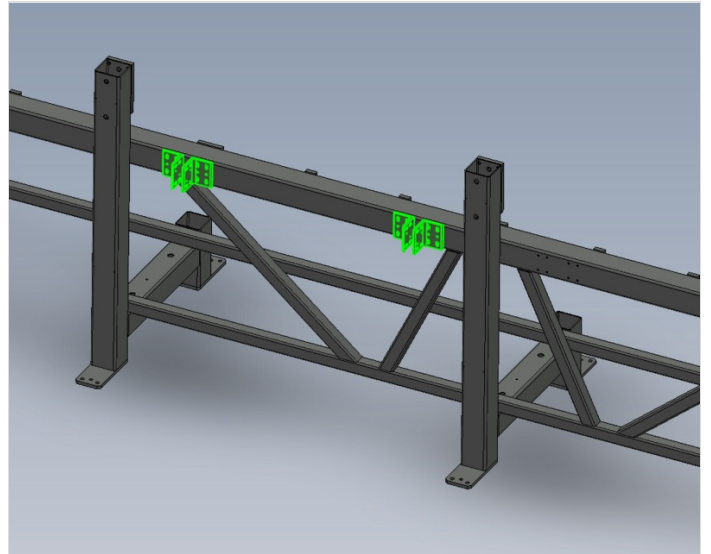
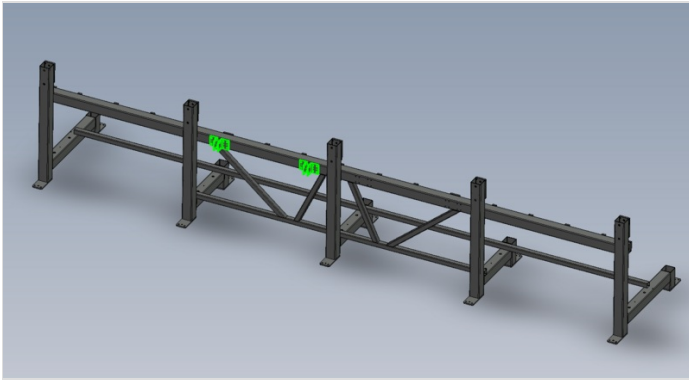



Step 7 - Fit cylinder assembly to frame

Lightly attach cylinder assembly to frame, orientated as shown. Use 16 off M8 x 25 socket caps with heavy M8 washers

Do not apply adhesive

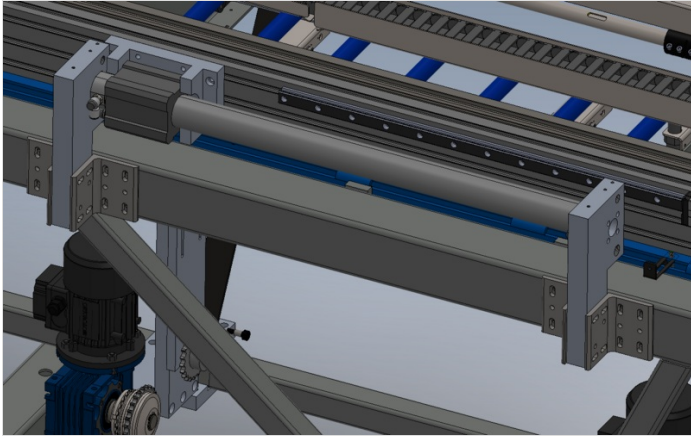

Step 8 - Check hepco position

Ensure hepco rail is still at correct datum position of 895mm

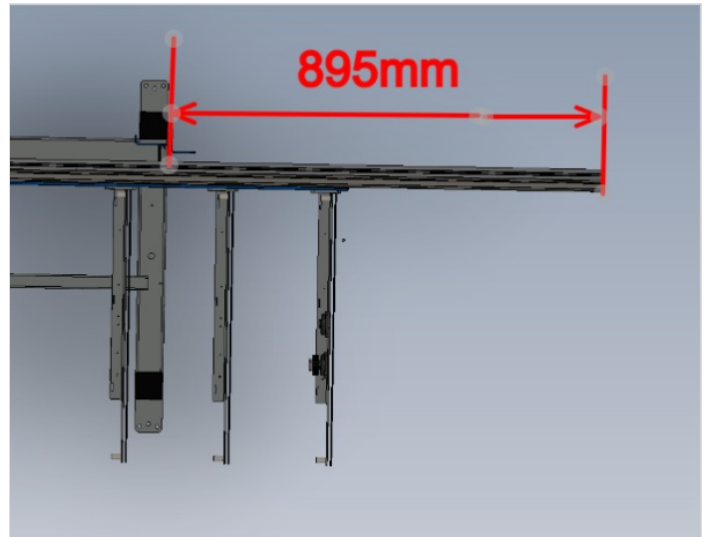

Step 9 - Position cylinder stroke

Check that cylinder is positioned as shown

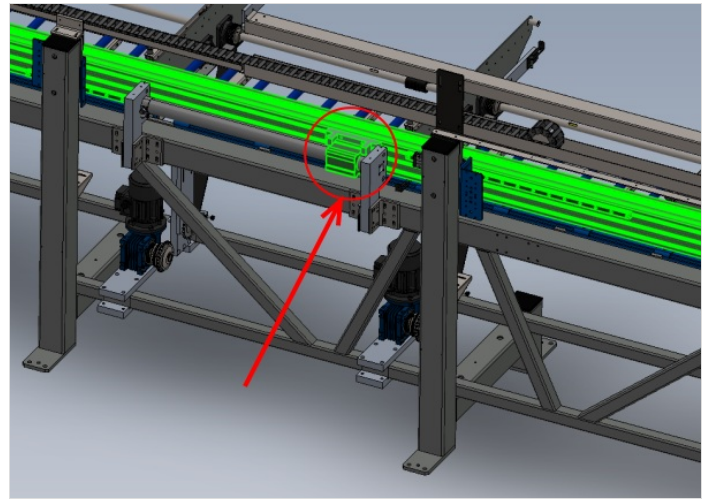

Step 10 - Attach cylinder to beam,

1 Attach cylinder to beam using M8 x 25 socket caps and 4 off F0000315 M8 D- nuts

2 Tension bolts to hold indicated bracket in a vertical position

3 Apply holding tension to these fasteners 1 and 2

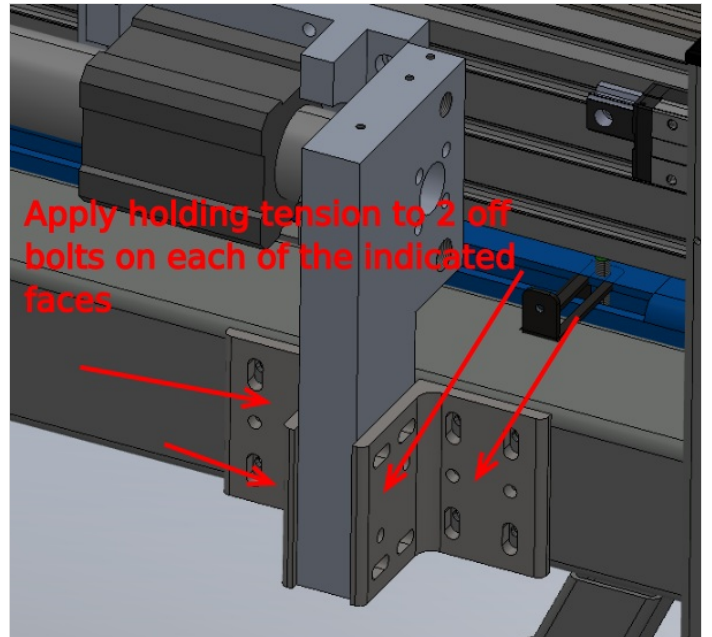
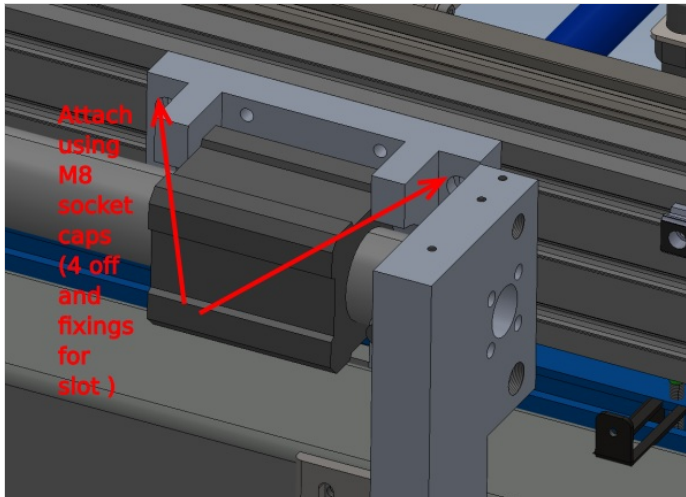

Step 11 - Attach second cylinder mounting bracket

1 Move hepco beam to extended position as shown

2 Apply holding tension to same bolts as other mounting bracket

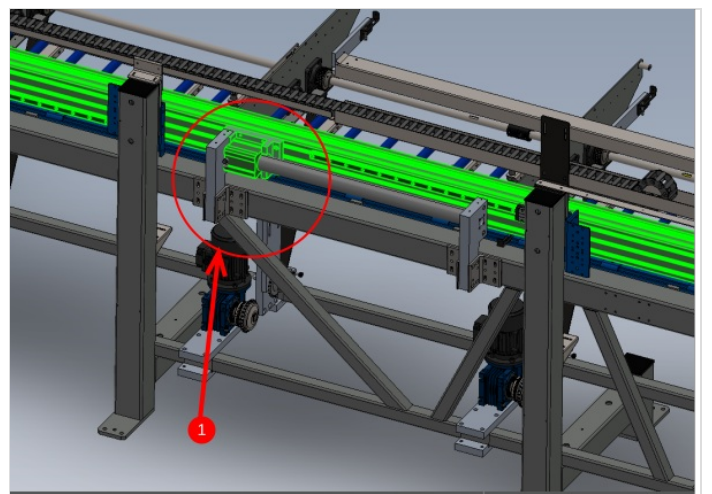

Step 12 - Check Movement

Quality check movement of beam from position 1 to 2

Movement must be free and consistent over the entire stroke of the cylinder

1 If not alignment must be rechecked by adjusting mounting brackets to obtain smooth running

2 Once Movement is free running , secondary check alignment by removing tension of fasteners holding cylinder mount block to hepco beam

3 Check that slight movement is possible between the hepco rail and the mounting block. Block should not move away from hepco rail when un fastened or be held against under pressure. If either of these happen it indicates mis alignment between components , and step 1 should be repeated

4 Tension m8 socket caps and apply final tension

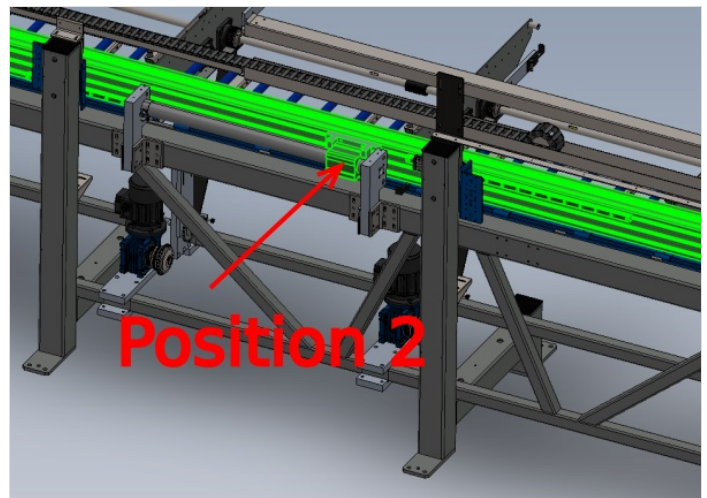
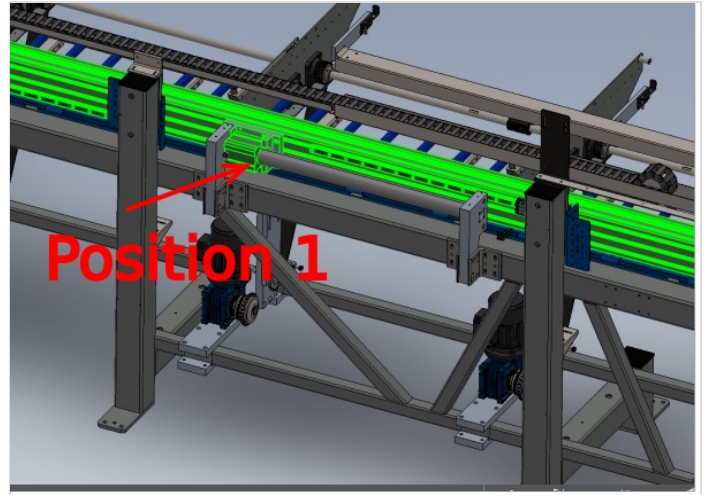

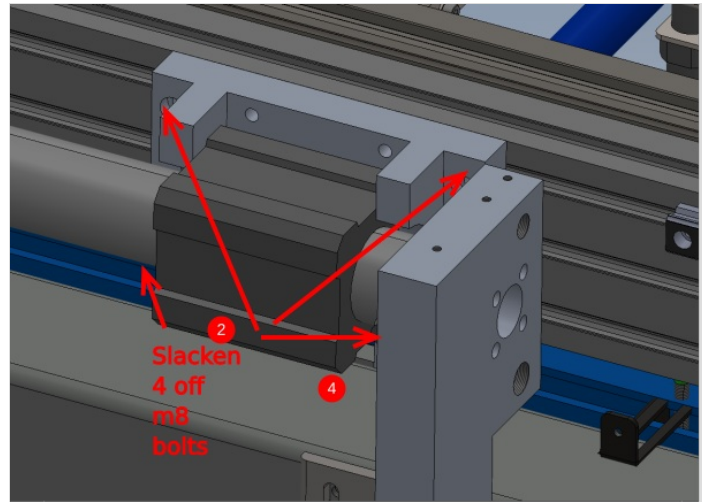
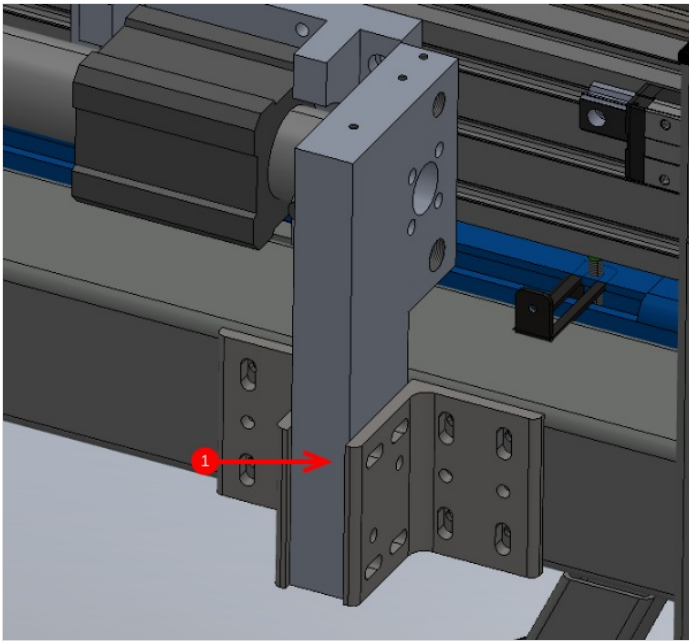

Step 13 - Finalise fasteners

Once alignment has been achieved, 32 off M8 socket caps will need to be individually removed, adhesive applied and finalised.

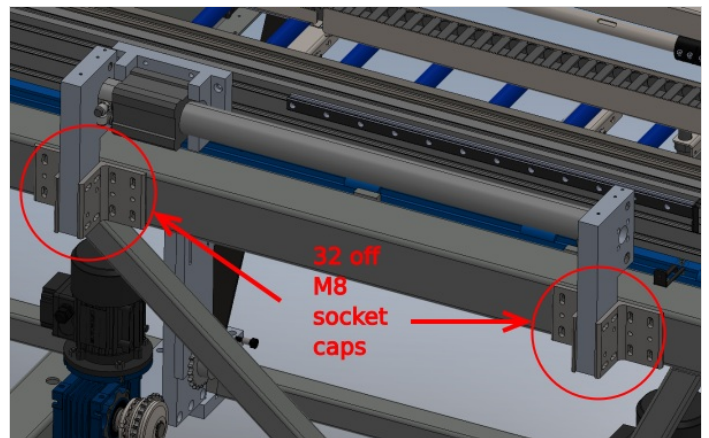

Step 14 - Add hard stops and dampers

1 off of each per side

1 Use 2 off M16 x 80 set bolts and standard M16 nuts

2 P0000109 damper x 2

Do not fully wind in either parts

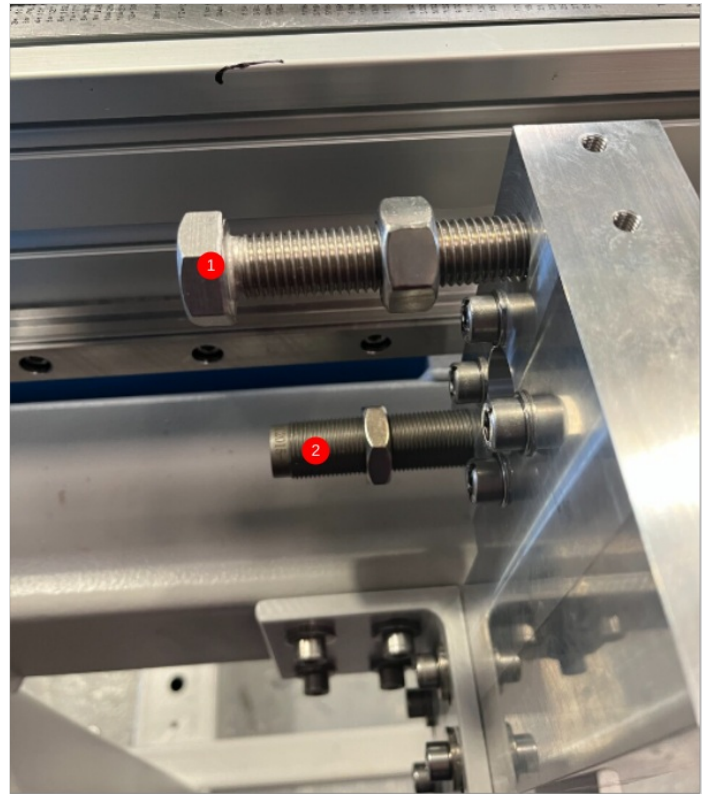

Step 15 - Set cylinder stroke hard stops

Move beam to full cylinder extension in one direction.

1 Linisher flat end of set bolt and adjust M16 set bolt to touch face of cylinder mount when in this fully extended position

2 Move beam away from bolt and rotate an EXACT 3/4 turn clockwise at the hex head to set stop position and lock off with m16 nut

3 Repeat for opposite end set bolt, moving cylinder stroke to the opposite end of travel

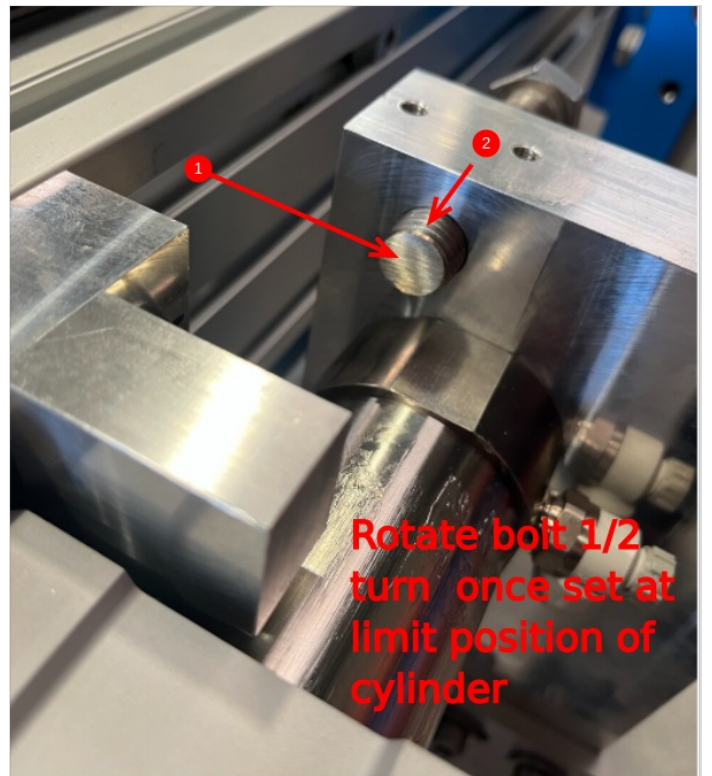

Step 16 - Set damper position

Set damper position by moving cylinder to full stroke, and adjusting damper so a gap of 5mm is left at the indicated point

Lock off damper lock nut

Repeat for both sides



Step 17 - Quality check

To check correct setting of stroke length, a measurement should be taken to confirm. To do this do the following steps.

- 1 Move cylinder to one position against set hard stop
- 2 Measure between Hex bolt thread end and cylinder anchor as shown
- 3 Confirm measurement is between the range of 696-698mm. Any measurement outside of this tolerance requires resetting of hard stops correctly

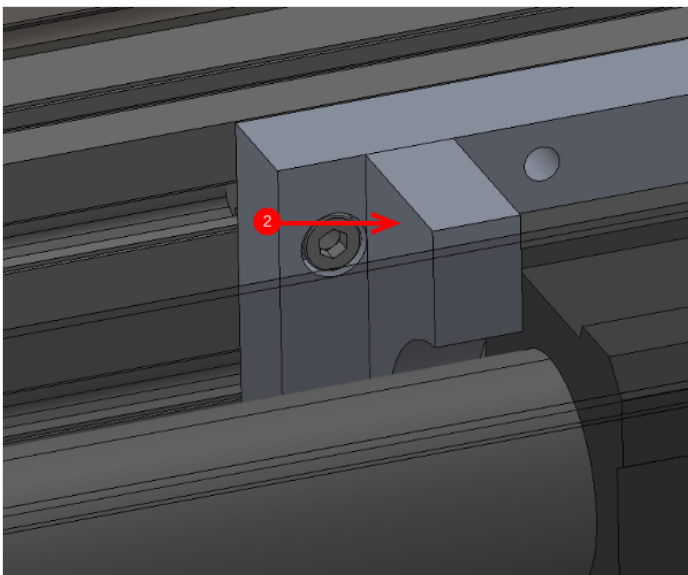
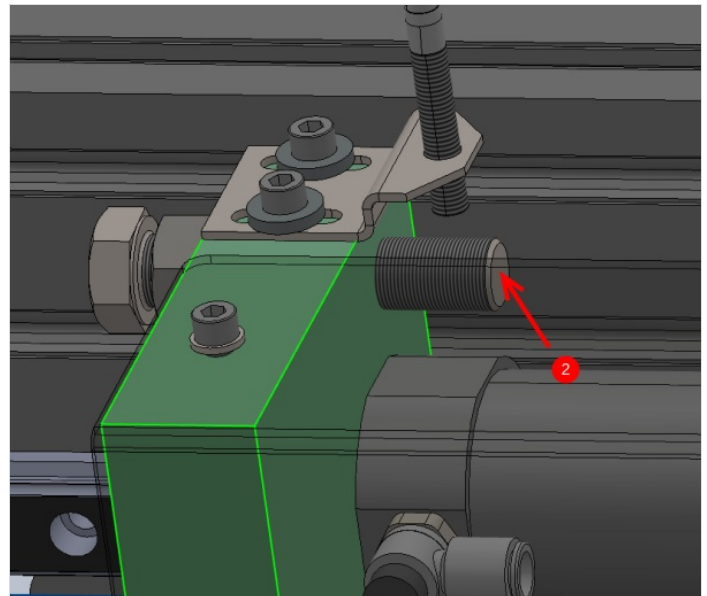
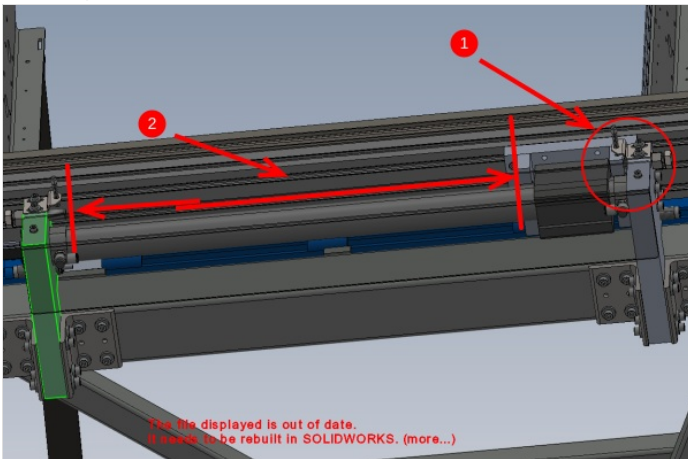

Step 18 - Attach sensors and brackets

1 Mount sensor brackets D0015144 with M6 x 16 socket caps x 2 and heavy M6 washers

2 Fit E0000336 sensor and Adjust bracket using slots to set sensor to edge of block when at full travel

3 Ensure sensor is set as close as possible to reading face

4 Repeat for other side

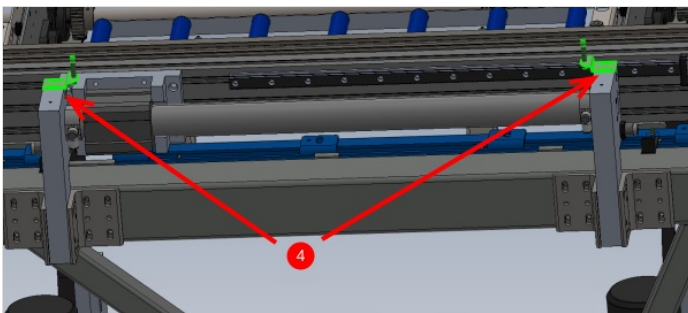
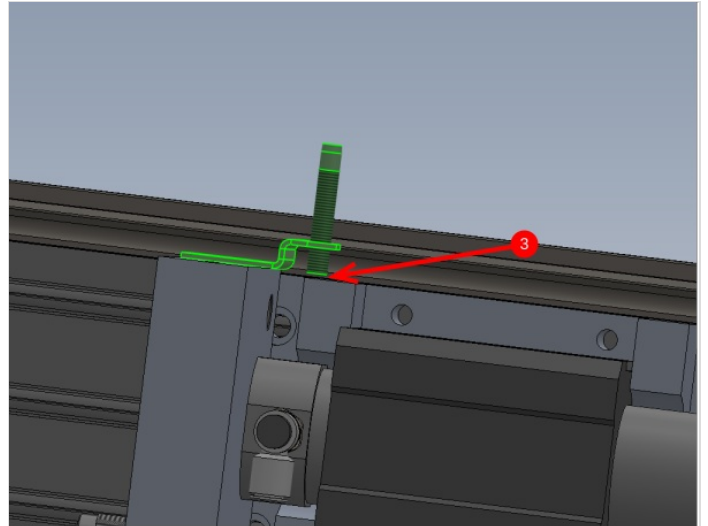
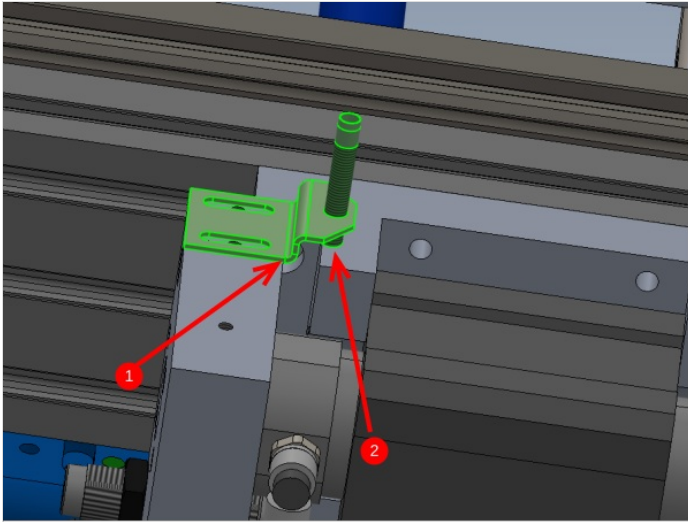

Step 19 - Fit cover

once all above steps have been followed, Guard D0015948 can be fitted

Pics and fastener sizes required
