

# R0015244 Frame ancillaries Fitting

instructions to fit wire basket and other parts onto frame

 Difficulty Easy

 Duration 2 hour(s)

## Contents

Introduction

Step 1 - Mount upper basket

Step 2 - Mount lower support brackets

Step 3 - Fit lower wire basket

Step 4 - Levelling brackets positions

Step 5 - Drill and Fit Levelling brackets

Comments

## Introduction

### Tools Required

115mm disc cutter  
Standard Hex key set  
Standard spanner set  
Standard tape measure  
Standard Tap set  
Standard HSS drill set

### Parts Required

A0001060 Support bracket :Cable basket Tray x 5  
A0001061 Retainer: Wire Basket Cable Tray x 7  
A0001065 Wire cable tray 3m length x 2.5  
D0015611 Reference Levelling Bracket x 2

## Step 1 - Mount upper basket

Cut 1 piece of A0001065 Wire cable tray to the length shown ( 7 sections)

Drill and tap two fixing holes M6 to fit to indicated position on rear of blue support bar

Fix with 2 off A0001061 basket retainers as shown using supplied M6 fasteners with mounting bracket



---

## Step 2 - Mount lower support brackets

Fit 5 off basket support bracket to pre drilled holes at indicated points .

Secure using M8 x 20 socket caps and Large M8 washers

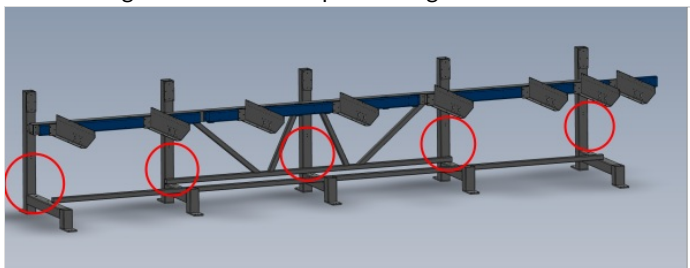



---

### Step 3 - Fit lower wire basket

Mount 2 full lengths of A0001065 wire basket to previous fitted brackets .

1 Join should be at central bracket between two sections and both baskets encapsulated with a retainer

2 Fix wire baskets to support brackets using 5 off A0001061 ( 1 retainer per bracket )

Use M6 x 20 button sockets, M6 penny washers and m6 nyloc nuts

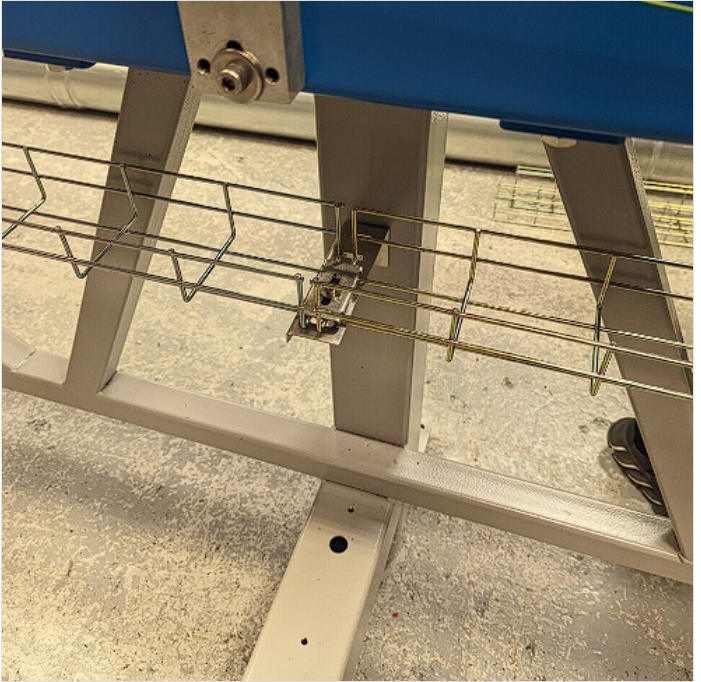
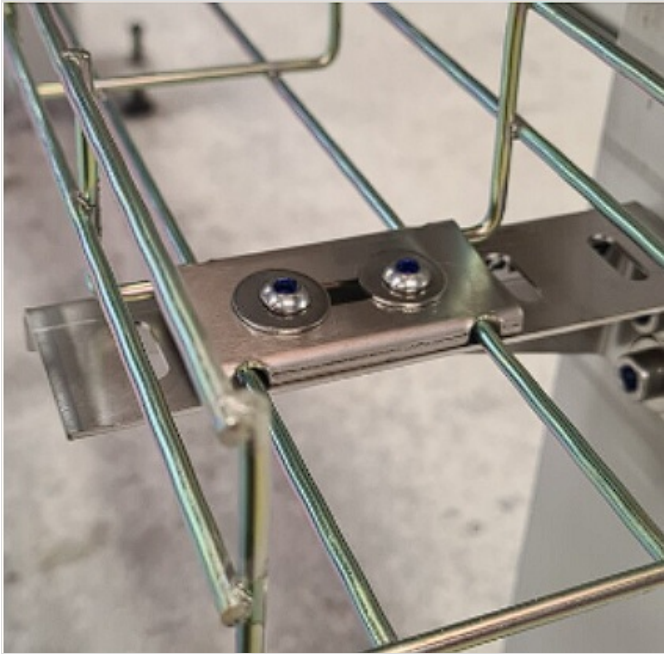
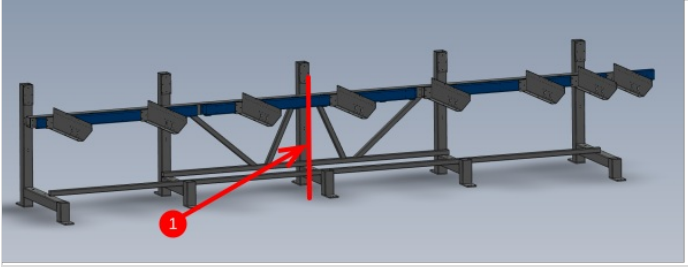



## Step 4 - Levelling brackets positions

2 off Levelling brackets D0015611 need fitting to indicated positions

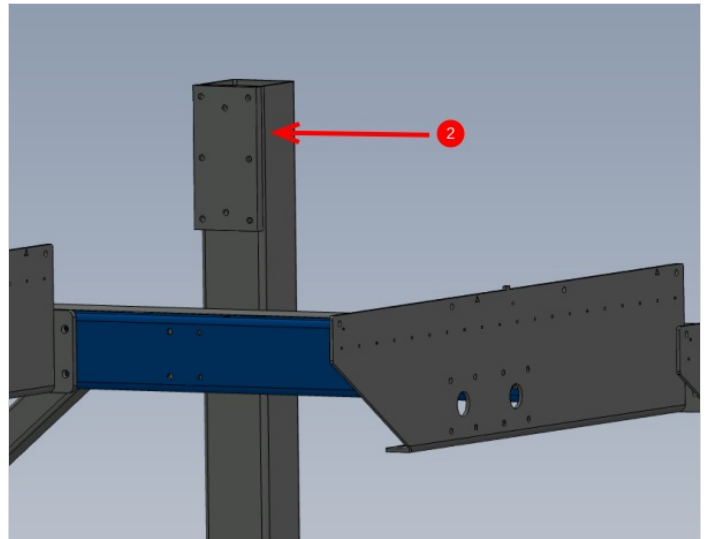
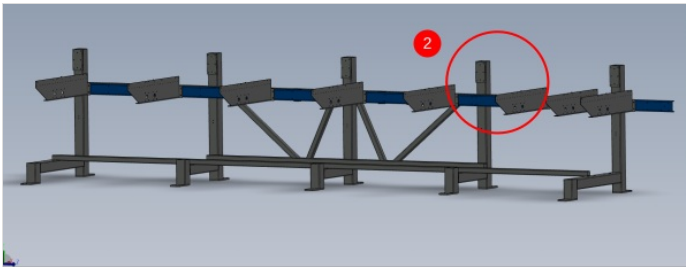
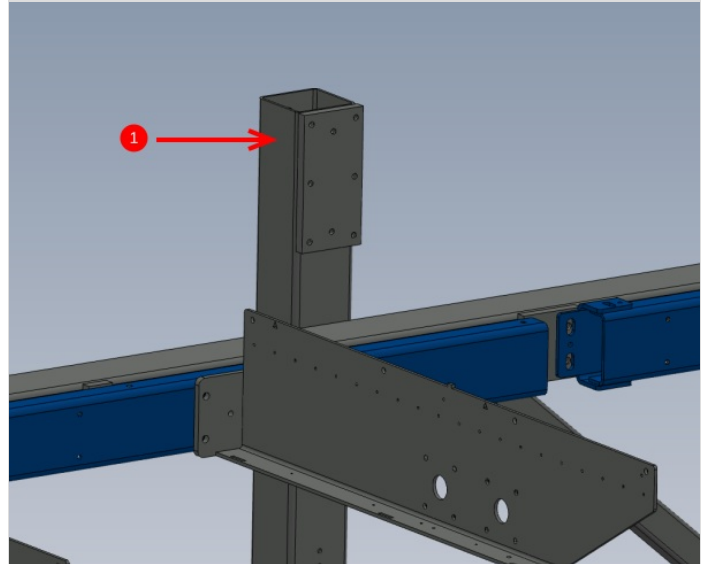
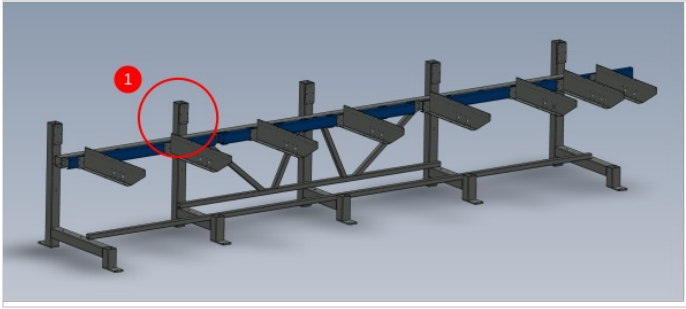

## Step 5 - Drill and Fit Levelling brackets

Position bracket as shown and drill 1 off M6 tapped hole and secure with M6 x 20 socket cap and heavy washer. Use engineers level to level bracket, then mark and drill second M6 tapped hole.

Finalise fasteners, whilst using level to ensure bracket remains level on the indicated plain.

Repeat for 2nd bracket position

