

# R0015243 ZX5 module A-C-E Frame levelling

Method for levelling bare frames for modules A,C and F for ZX5/3 Preparing frame for production

 Difficulty Easy

 Duration 3 hour(s)

## Contents

Introduction

Step 1 - Clean all tapped threads on frame

Step 2 - Add jacking bolts

Step 3 - Add levelling pads

Step 4 - Level Y axis

Step 5 - Level x axis

Step 6 - Fit frame endcaps

Comments

## Introduction

### Tools Required

Standard taps set

standard spanner set

2 meter straight edge

1" parallel blocks

300mm engineers level

### Parts Required

D0015265 Frame

M0000224 100x 100 frame cap 10 off

F0000234 M16 x 1.5 nut 10 off

F0000266 M16 x 1.5 set bolt x 10 off

## Step 1 - Clean all tapped threads on frame

Tap all holes to remove debris from coating process

Ensure all holes cleaned after tapping with compressed air

 ...Ensure eye protection is worn when using compressed air

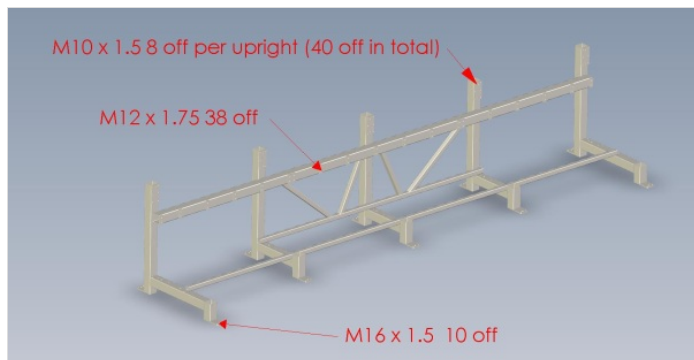

## Step 2 - Add jacking bolts

Fit 10 off m16 x 1.5 x 120 set bolts with standard m16 x 1.5mm nut and copper slip to lubricate lock nut and thread into frame.

 ...~check that nut runs freely up entire length of m16 set bolt before fitting to frame

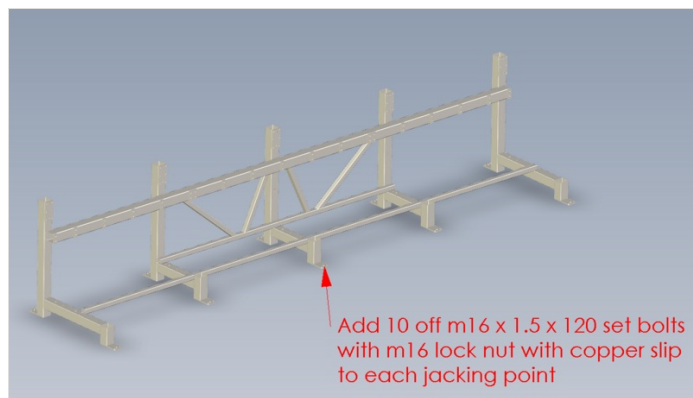

## Step 3 - Add levelling pads

Use a pallet truck to lift frame.

Wind through M16 bolts until approximately 40mm protrusion from below base of foot

Locate each bolts into black nylon levelling pad

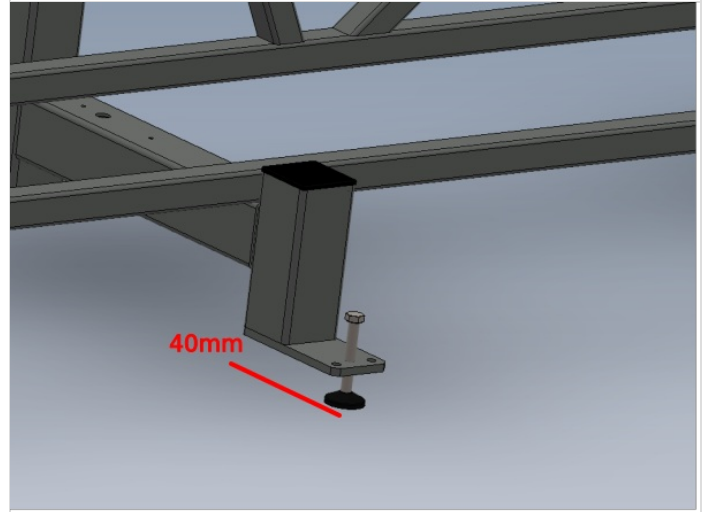
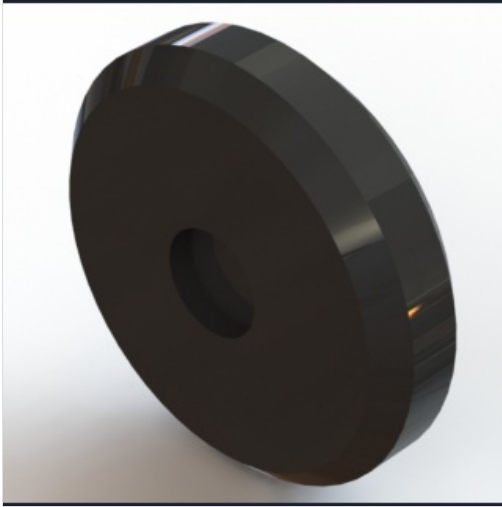

## Step 4 - Level Y axis

- 1 Attach levelling jigs to 5 points across frame
- 2 Use level on jig to indicate current state of level
- 3 Check across all 5 points to identify where to lift frame to achieve level
- 4 Lift frame by jacking bolts to achieve level on level jigs

**⚠** ...Do not try and lift solely on one jacking point. This will cause the frame to rock and give a false level indication.  
Bolts should be increased uniformly until close to desired levelling point.  
For example, 1 turn clockwise on bolt 1, then 2,3,4 and 5 then repeat

- 5 Adjust level on Y axis until all level points are correct.

**⚠** ...Report any discrepancy to Supervisor if levels can not be achieved

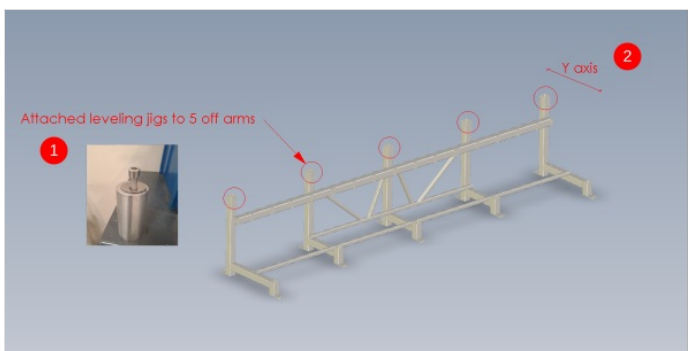

## Step 5 - Level x axis

**i** ...level for x axis will be achieved from using the 5 points indicated. Do not use any other points for levelling, as box section will vary and give inconsistent results.

1 Place one parallel at point 1 and 1 parallel at point 2. Span these with a 2mtr straight edge and use engineers level on top of straight edge to show current level

2 Repeat this between point 2 and 3 , then 3 and 4 and finally 4 and 5. This will highlight the movement required to level frame

3 Use the same method as the Y axis

**!** ...only adjust the indicated bolts in pairs as shown. Failure to do this will lose y axis setting done previously. Ensure accurate turns of bolts are achieved when adjusting . Ie, if point one needs to raise, adjust both indicated bolt 1's exactly the same amount

4 achieve all points 1-5 level , any discrepancy should be reported to the Supervisor

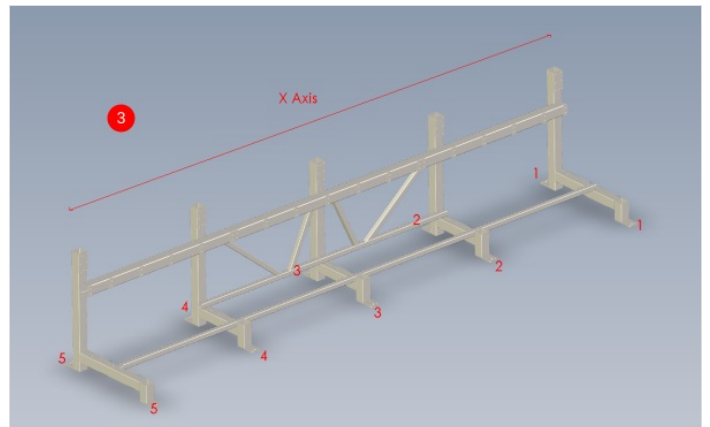
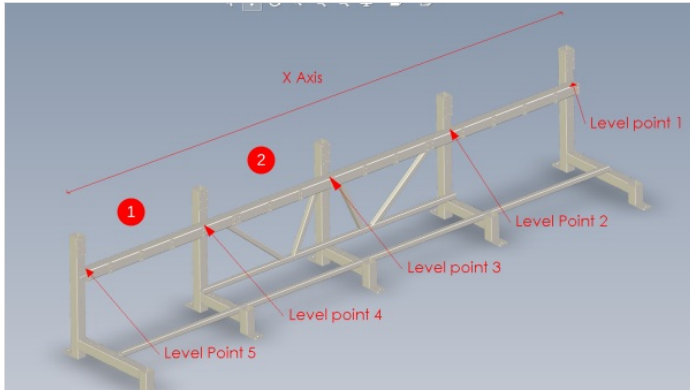

## Step 6 - Fit frame endcaps

Frame end caps will now need fitting to frame

10 off M0000224 fitted to all open cavities of 100mm square box section

