

R0015096 (e) Bench Assemble Transfer Drive Assembly

Instructions to bench assemble drive assembly

 Difficulty **Medium**

 Duration **1 hour(s)**

Contents

Introduction

Step 1 - Unless otherwise stated

Step 2 - Assemble chain tensioner

Step 3 - Attach to mounting plate

Step 4 - Attach Base

Step 5 - Check motor assembly configuration

Step 6 - Fit Drive shaft

Step 7 - Check Configuration of clutch

Step 8 - Fit clutch to motor

Step 9 - Mount motor to base

Step 10 - Attach clamps

Comments

Introduction

Tools Required

External circlip pliers
Internal circlip pliers
Standard hex key set
Standard spanner set

Parts Required

H0007576 x 1
B0000139 x 1
D0007577 x 1
D0015626 x 1
D0015561 x 1
D0015562 x 1
B0001167 x 1
D0015024 x 1
B0001100 x 3
B0001166 x 1
B0000229 x 1
D0015610 x 2

Step 1 - Unless otherwise stated

Use Loctite 243 on all fasteners

Use Loctite 572 on all pneumatic threaded connections

Pen mark all bolts to show finalised



Step 2 - Assemble chain tensioner

1 off

1 Press bearing B0000139 into sprocket H0007576.

If fit is loose, use FE10 solvent to degrease parts and apply bearing fit to fix.

If fit is tight, inspect parts to Drawing to confirm correct sizes

2 Press D0007577 into sprocket and follow above for correct fitment .

3 Captivate with 20mm external circlip

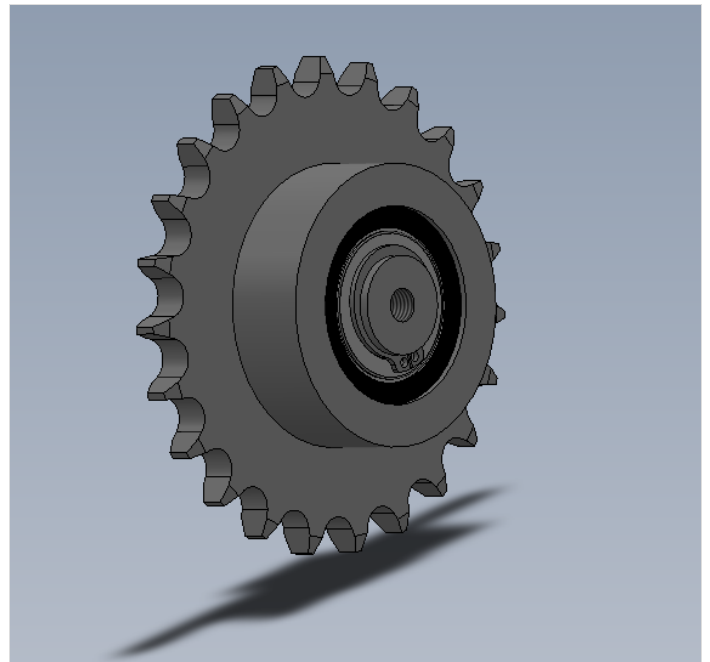
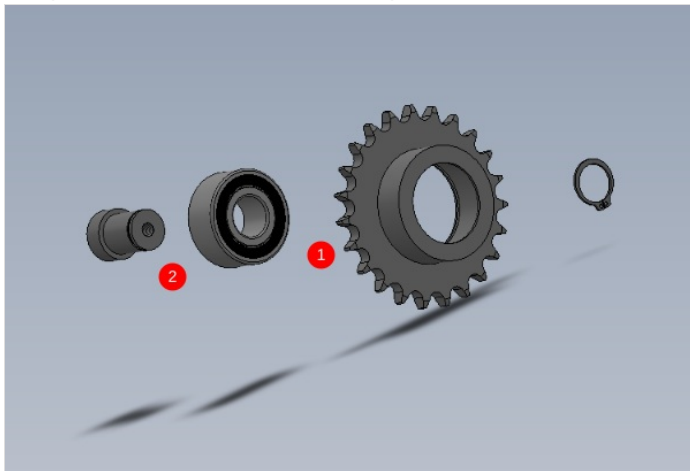

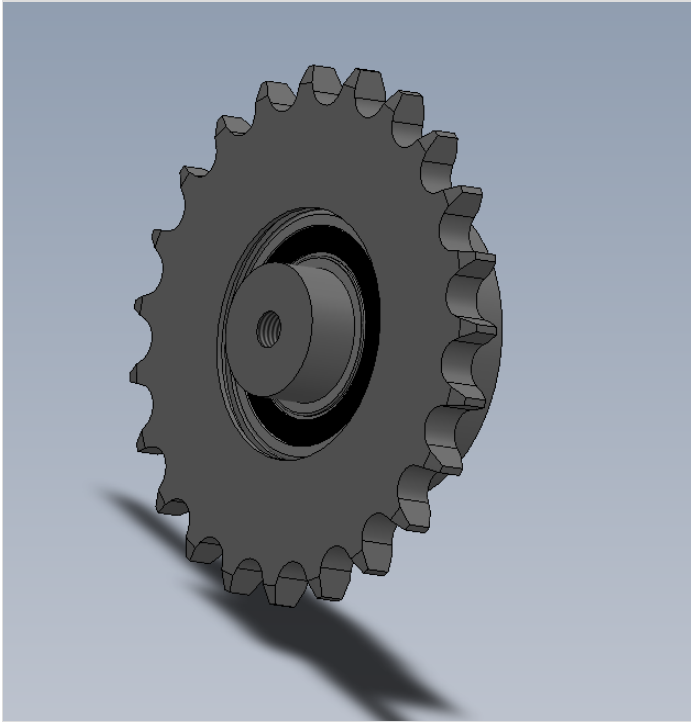

Step 3 - Attach to mounting plate

1 off

Attach sprocket assembly to D0015626 Using M8 Socket cap (length Required)

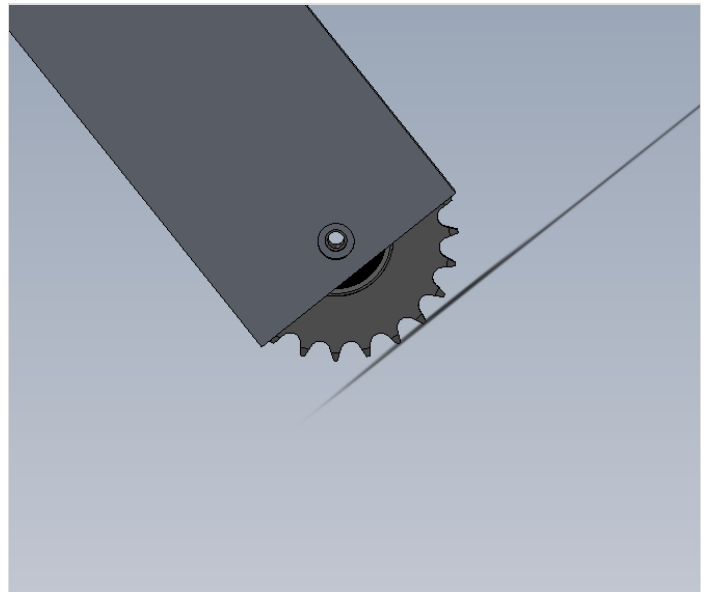
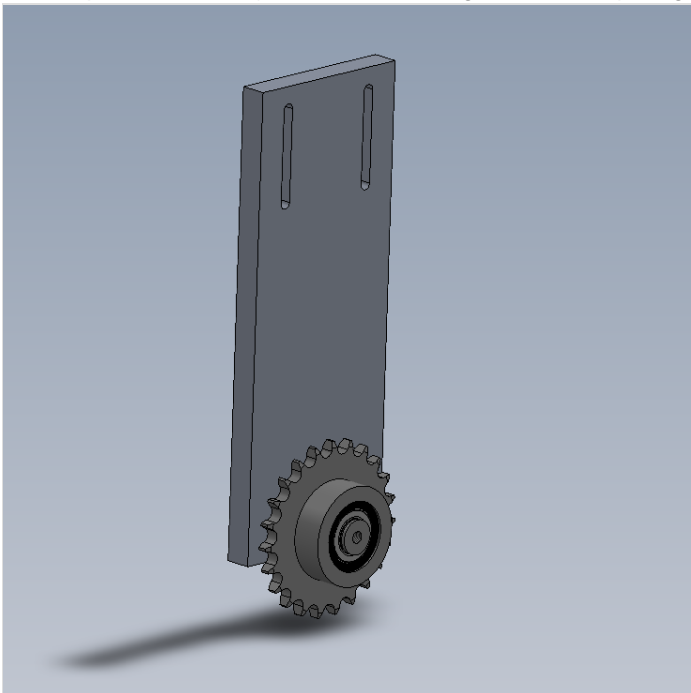

Step 4 - Attach Base

1 off

1 Attach D0015561 to D0015562 as shown using 3 off M8 socket caps (size required)

2 Mount assembled sprocket plate using M6 x 30 socket caps and heavy F0000247 M6 washers

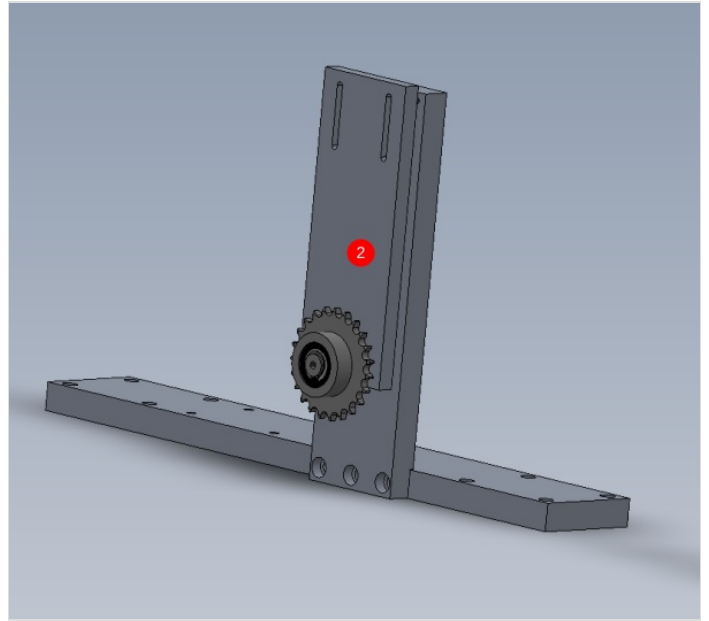
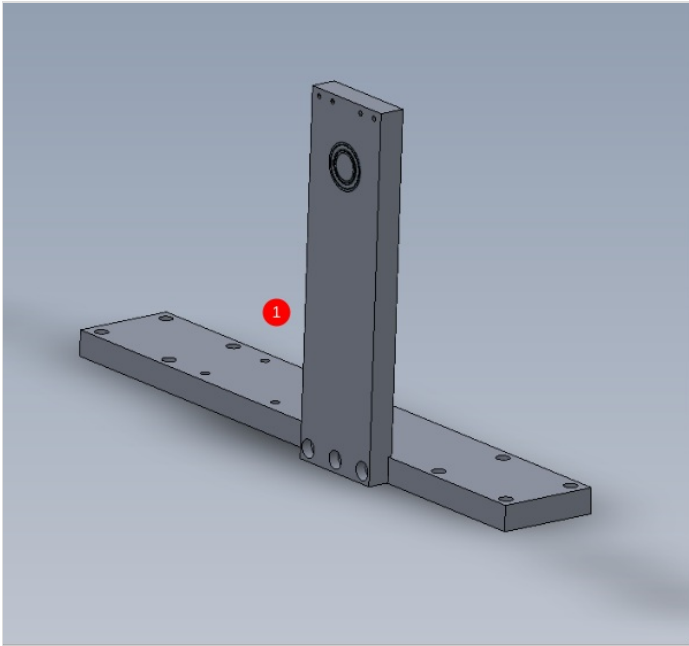

Step 5 - Check motor assembly configuration

Check motor has been supplied in the shown configuration.
Gearbox may need rotating on supplied motor assembly to match orientation shown.
Motor terminal box position is vital

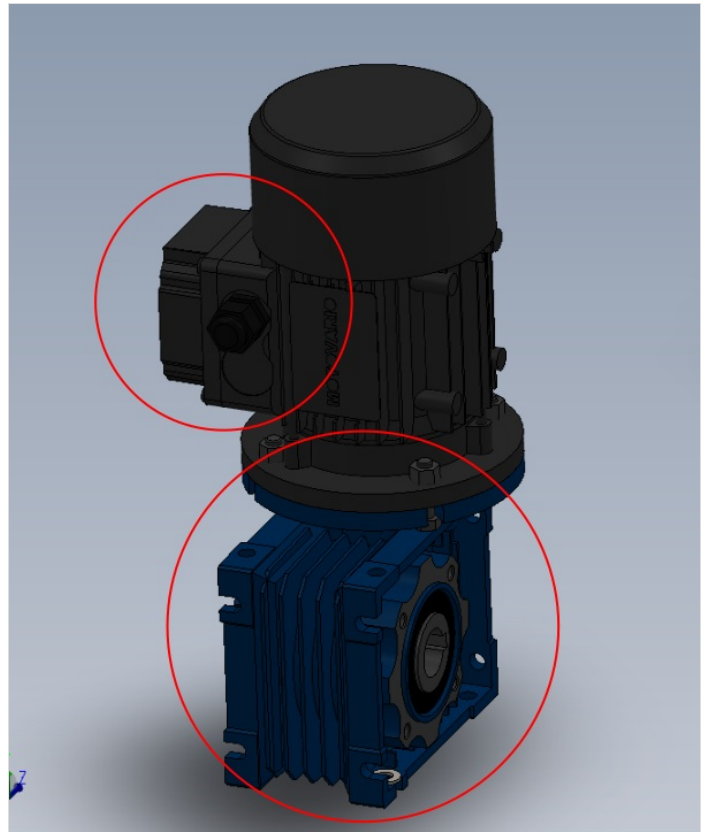

Step 6 - Fit Drive shaft

1 off

1 Insert 3 off B0001100 key into driveshaft

2 Insert driveshaft D0015024 as shown and captivate either side with external circlip (size required)

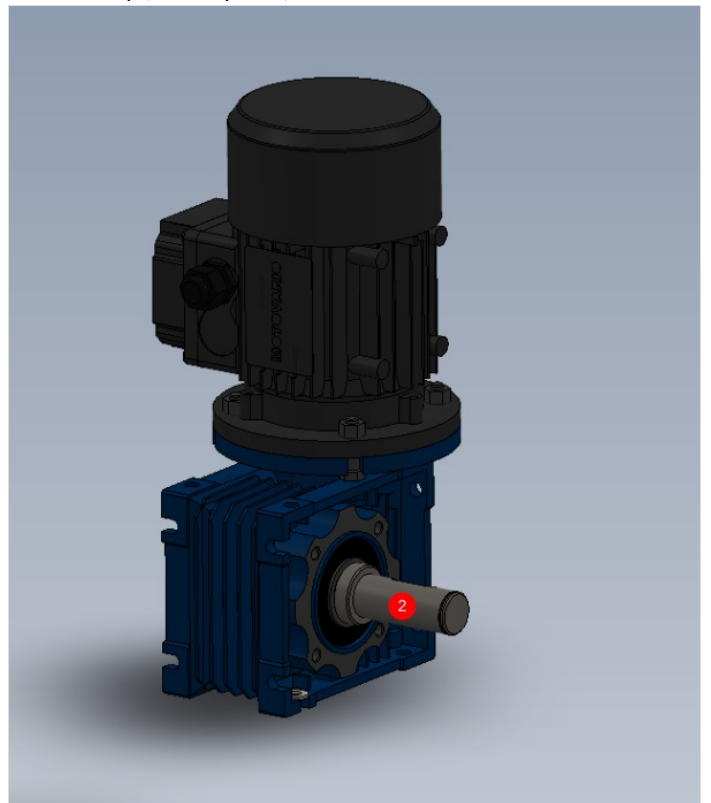
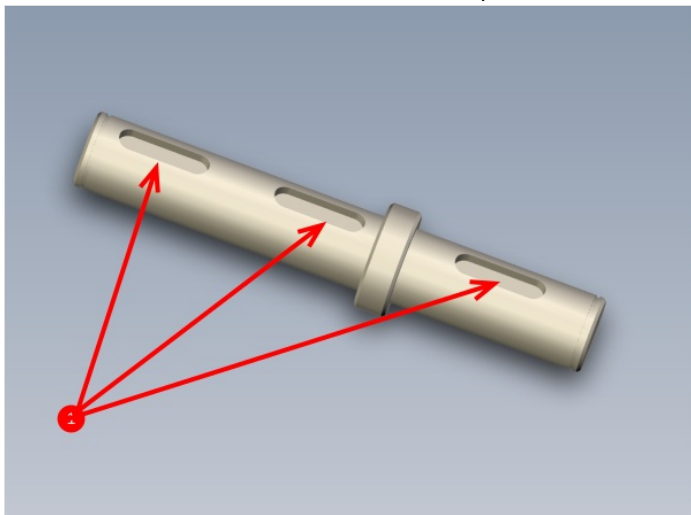

Step 7 - Check Configuration of clutch

Check B0000229 has been assembled in the correct order

- 1 C Spanner pressure nut
- 2 Locking washer
- 3 Spring washer 3 off
- 4 Spreader plate
- 5 Friction washer
- 6 Centralise boss
- 7 Drive sprocket
- 8 Main Flange

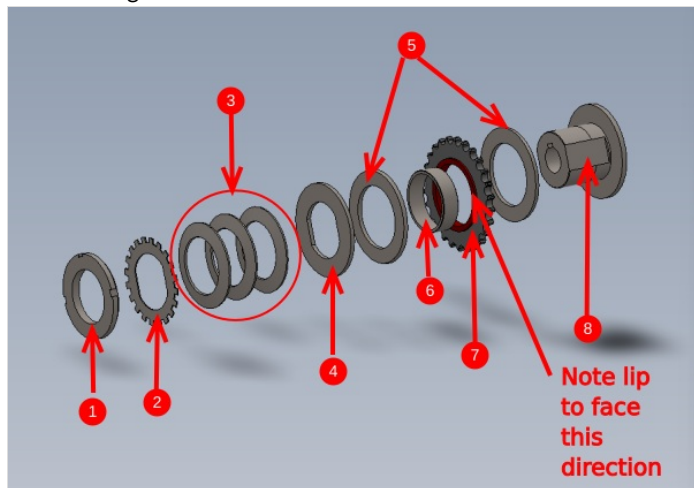

Step 8 - Fit clutch to motor

1 off

Mount clutch assembly as shown and captivate with 25mm external circlip

ECR raised 12/06/23 to address problem of grubscrew lock off missing key fitted.

Until corrected, use M6 x 10 kcp grubscrew to lock on to shaft

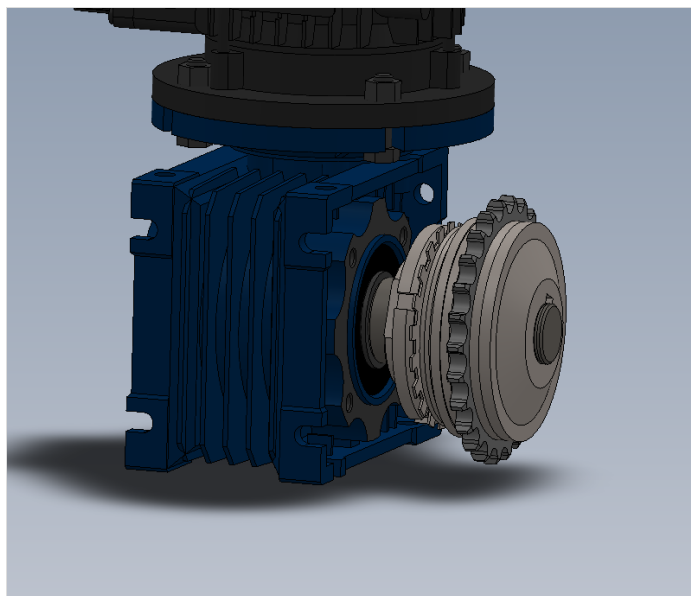

Step 9 - Mount motor to base

2 off

Attach motor to base as shown

Use M8 hex set bolts , A form washers and M8 nyloc nuts to secure

4 off mounting points

(Bolt Length required)



Ensure fasteners are long enough to pass through nyloc section of nut

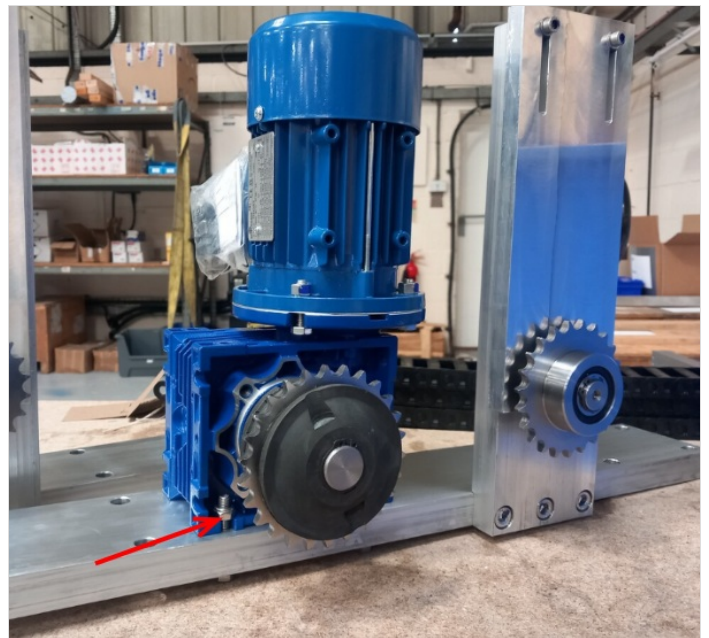

Step 10 - Attach clamps

2 off per assembly

1 off assembly

Use M12 x 100 hex set bolts (check size) and A form washers to attach 2 off clamp plates D0015610 to assembly as shown



.....Do not apply adhesive to these as they will be removed for installation later on

