

Toggle navigation

Search

- [Categories](#)
- [Manuals](#)
- [Items](#)
- [Answers](#)

Create a page

Permission Denied

Oops ! You do not have permission to edit this page because your are not log in. To edit this page [create an account](#) or [log in](#).

- [English](#)
- - [Log in](#)

R0015095 Bench Assemble Infeed Support Arms

- [Page](#)
- [Comments](#)0
- [History](#)

Star

0

I did It

0

- [...](#)
- [Export PDF](#)
- [Embed this tutorial](#)
- [Generate a QR code](#)

This page contains [changes](#) which are not marked for translation.

Instructions to bench assemble infeed support arms

Author [Gareth Green](#) | [Last edit](#) 5/09/2024 by [Gareth Green](#) being drafted

□
 Difficulty
 Medium
 Duration
 5 hour(s)

Instructions to bench assemble infeed support arms

Difficulty
 Medium
 Duration
 5 hour(s)

Contents

- [1 Introduction](#)
- [2 Step 1 - Unless otherwise stated](#)

- [3 Step 2 - Hand of parts issued determines handing.](#)
- [4 Step 3 - Clean all threads](#)
- [5 Step 4 - Align spacers and fit setting jigs](#)
- [6 Step 5 - Fix Rail to arm](#)
- [7 Comments](#)

Introduction

Tools Required

Standard hex key set

Standard tap sete

Setting jigs

Parts required

B0001170 Spacer 180 off

B0001155 open rail 18 off

D0015553 Transfer Support arm R/H (right to left machine) OR D0015552 Transfer Support Arm L/H (Left to Right machine)

D0015554 x 18

M8 x 20 button hex fastener x 18

M5 x 25 socket cap x 180

M5 A form washer x 180

Step 1 - Unless otherwise stated

Use Loctite 243 on all fasteners

Use Loctite 572 on all threaded pneumatic connections

Pen mark all bolts to show finalised

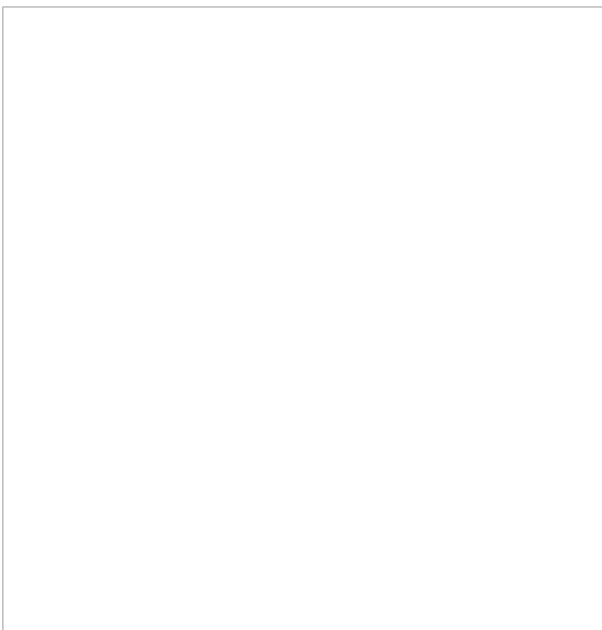



Step 2 - Hand of parts issued determines handing.

Steps shown below will show location and position of parts and procedure for fitting , not orientation

[R0000711 Rotary Base Assembly quality-assurance-testing.png](#)

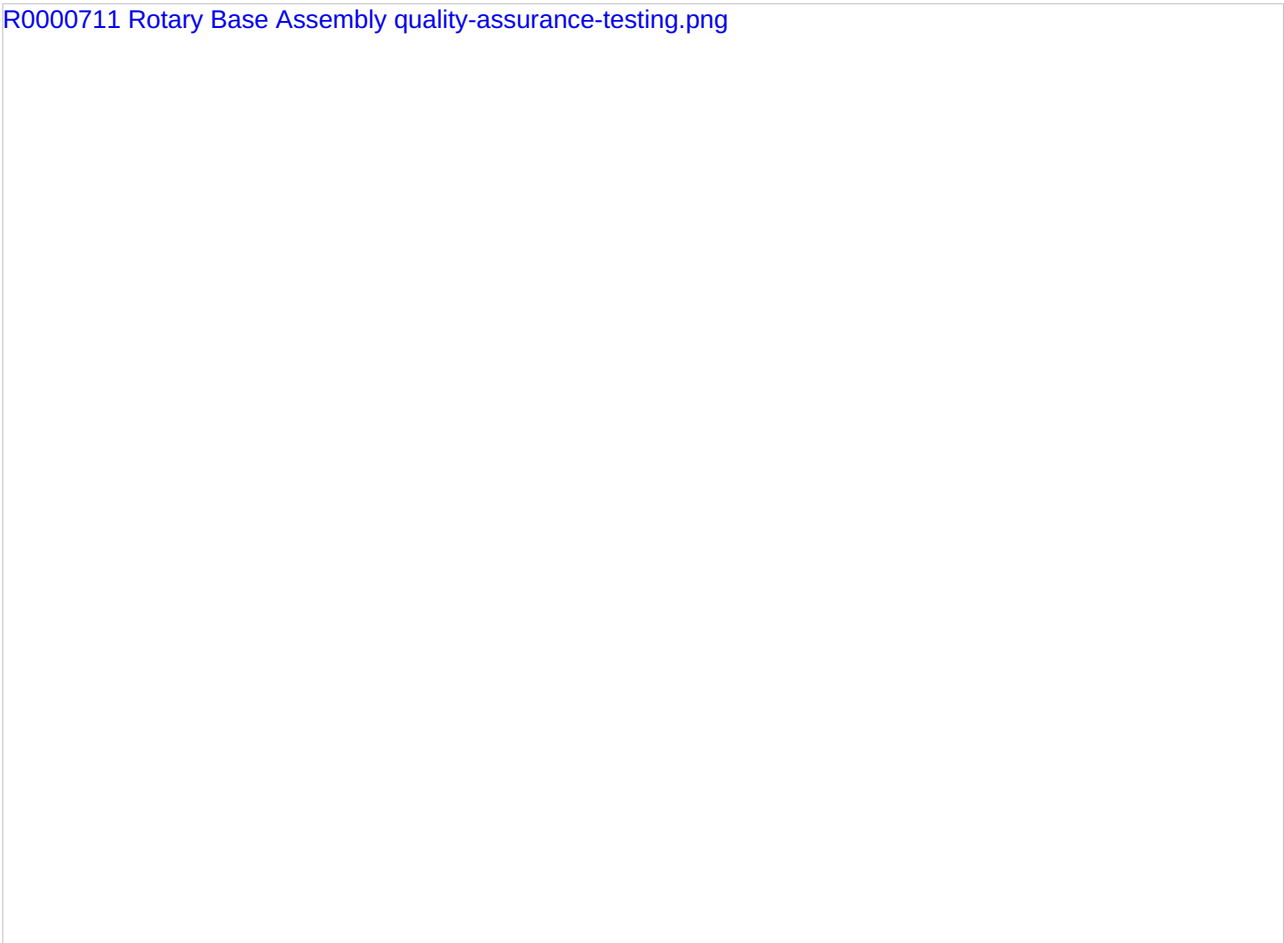

Step 3 - Clean all threads

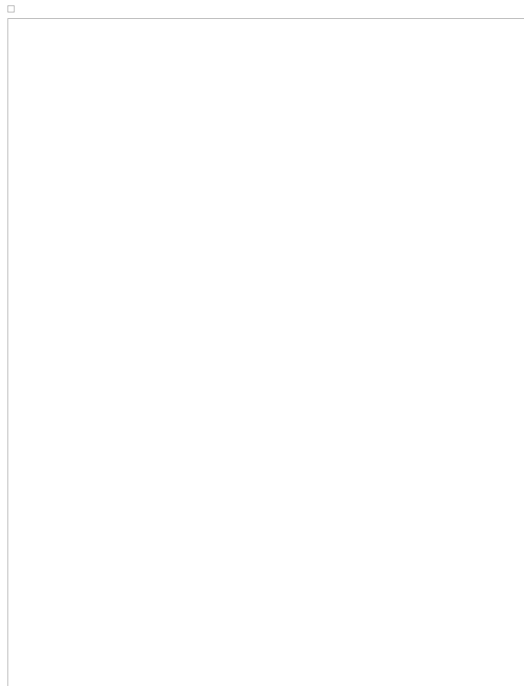

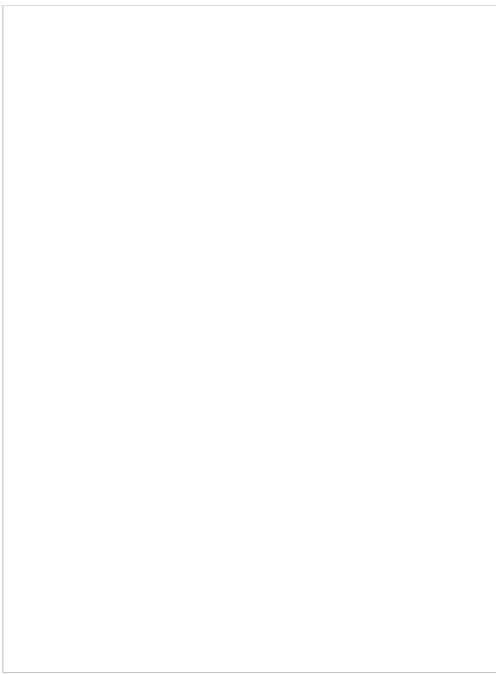

1.

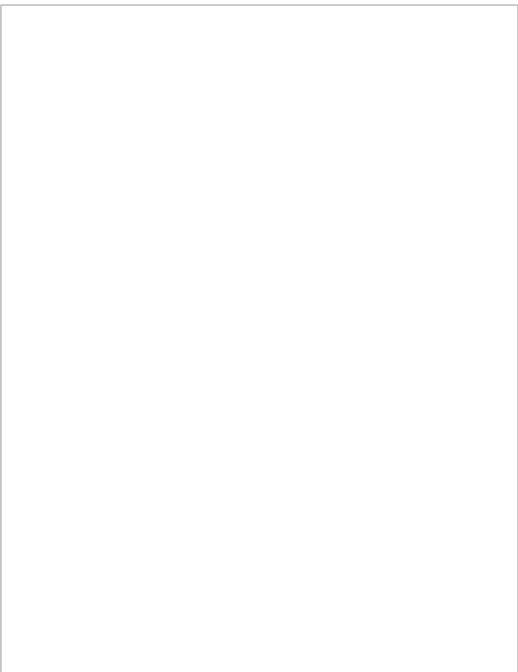

2.

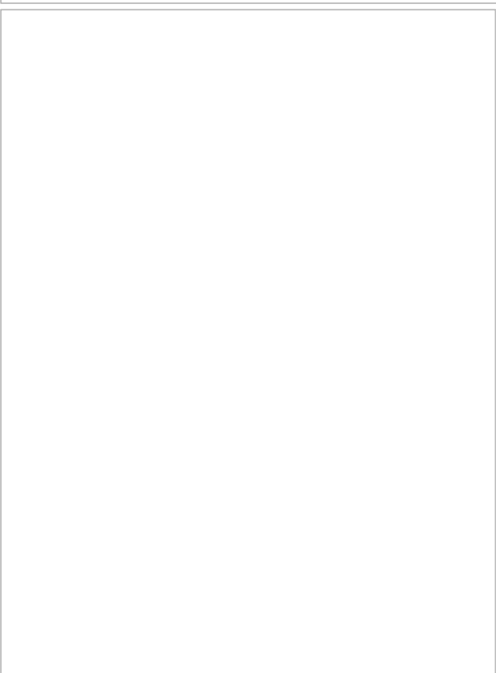

3.

□

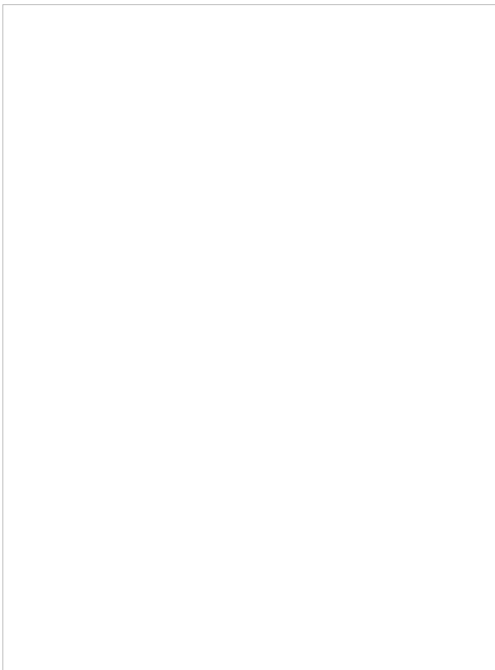
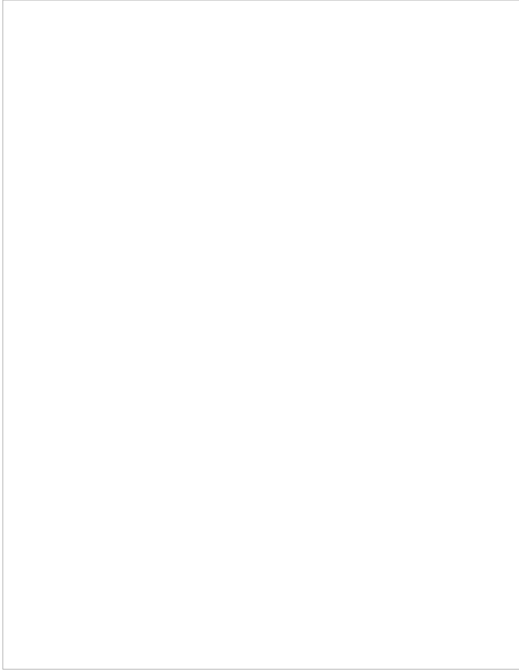

Step 4 - Align spacers and fit setting jigs

1 Mount 4 off setting jigs to arm on the indicated points

2 align 20 off spacers over all m5 holes

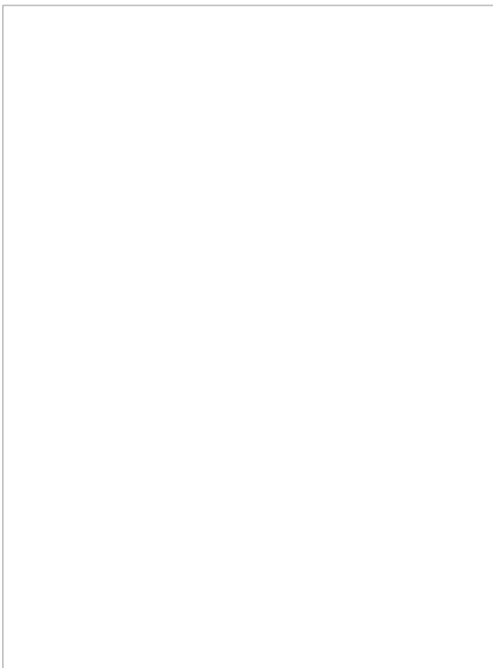
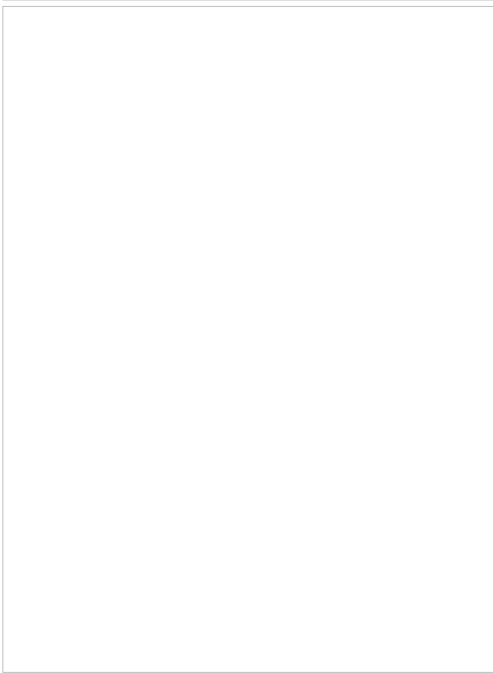
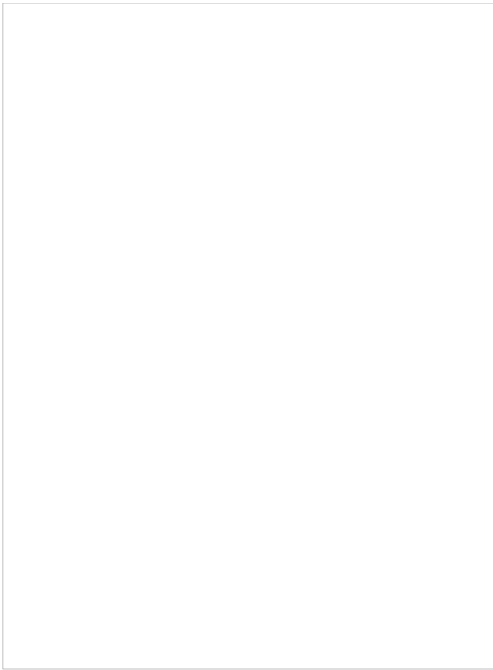

1.

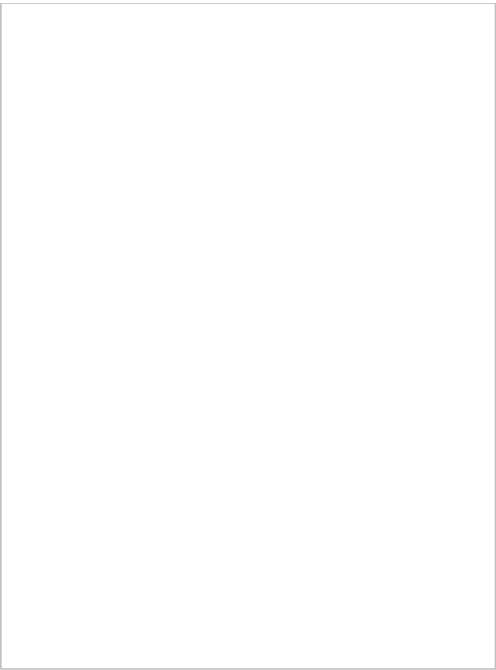

2.

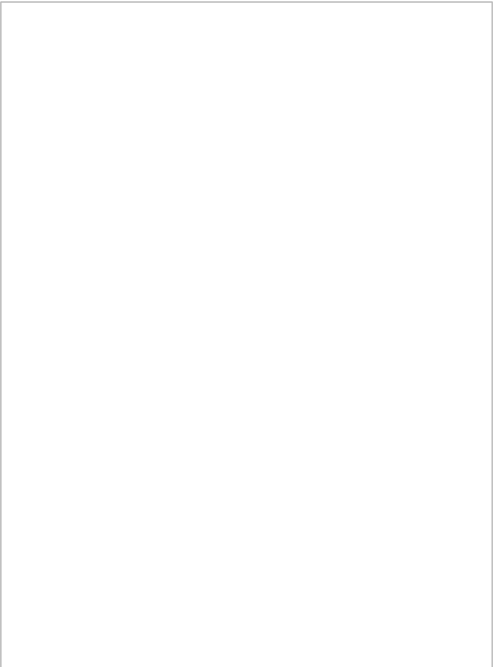

Step 5 - Fix Rail to arm

1 Use M5 x 25 socket cap and A form washer with loctite 243 to fix rail to arm

2 Ensure rail touching setting jig as indicated and two rails are pushed completely together



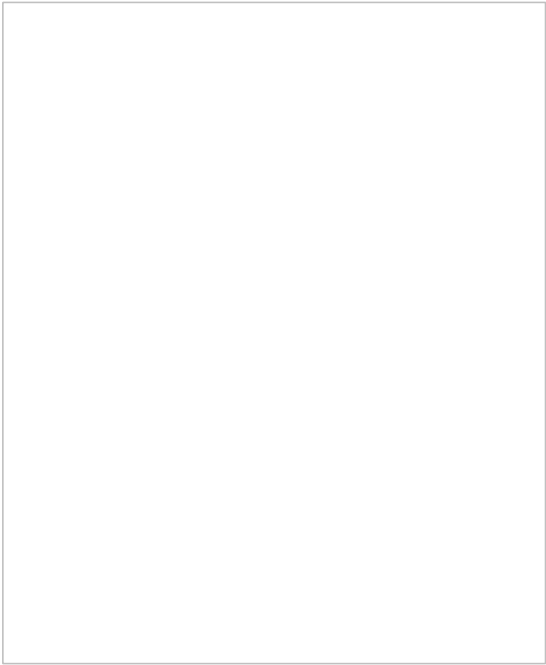
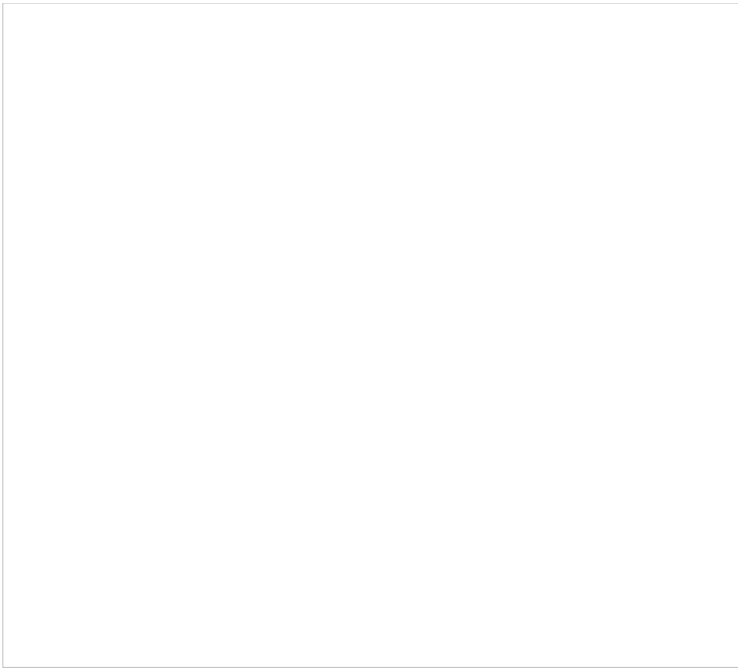

1.

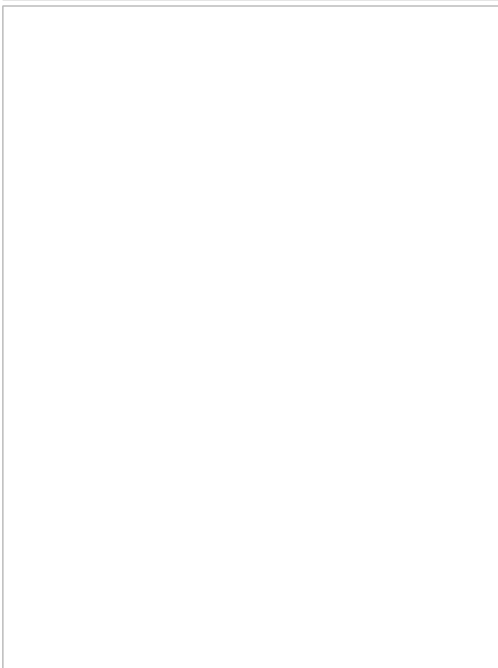

2.

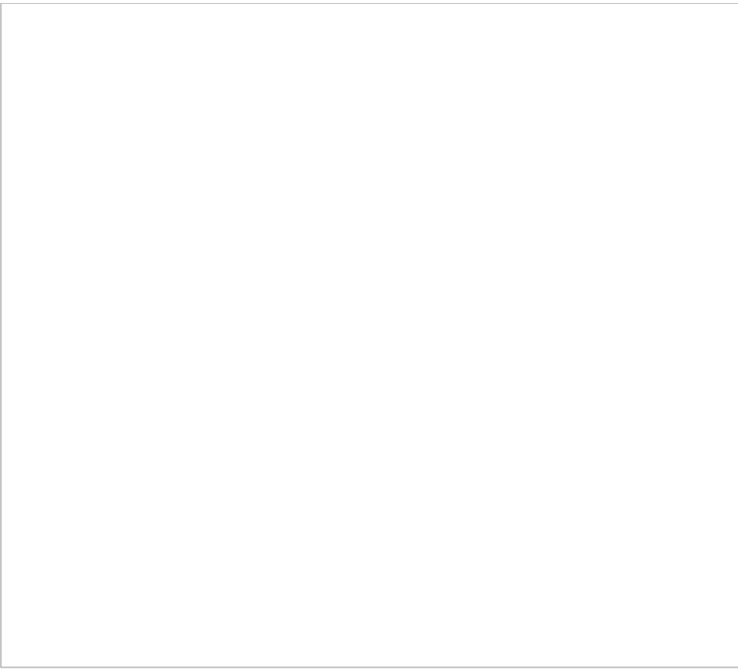

3.

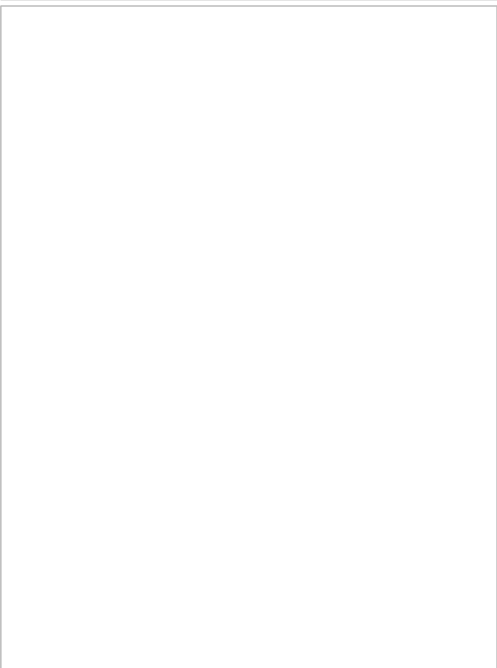
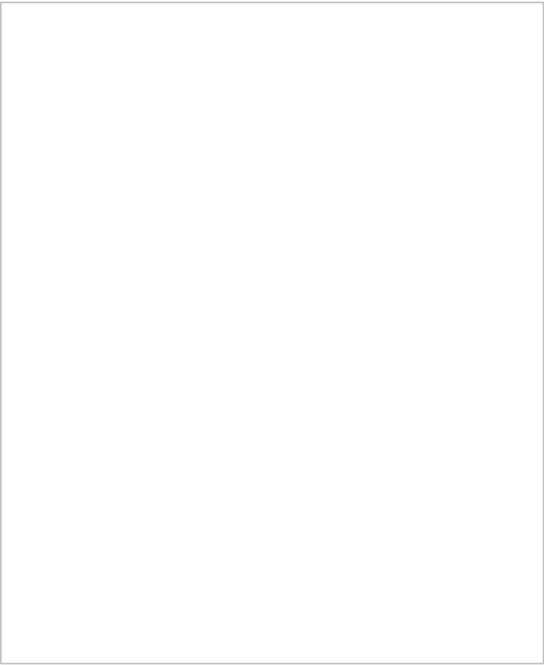

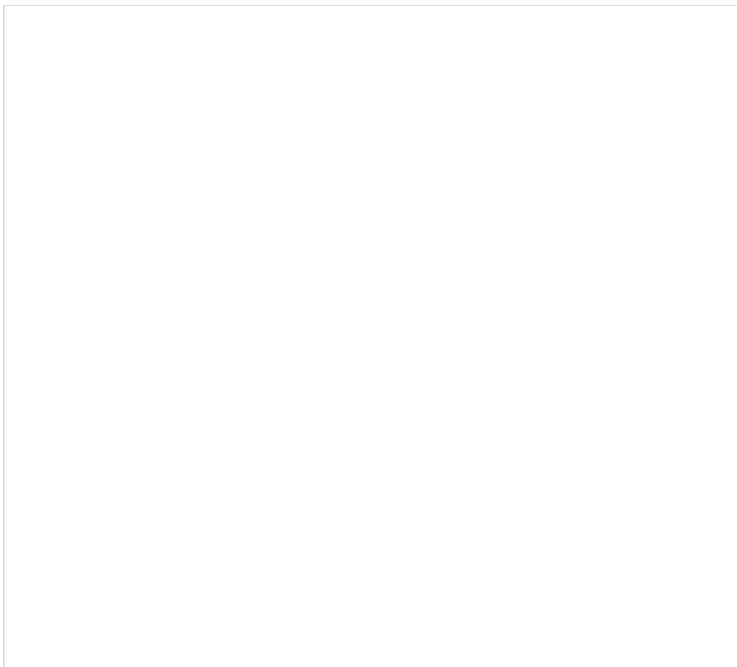

Comments

Draft

×

Error in page name

You entered an invalid page name, with one or many of the following characters :

< > @ ~ : * € £ ` + = / \ | [] { } ; ? #



Log in

You doesn't have an account ? Subscribe to get the best of the plateform !

×

Embed this tutorial on your website

Player size

Color

Copy-paste the code below on your webpage



Select a language

- Français
- English
- Deutsch
- Español
- Italiano
- Português

Cancel

Retrieved from "https://stuga.dokit.app/w/index.php?title=R0015095_Bench_Assemble_Infeed_Support_Arms&oldid=14378"

Categories:

- [Production](#)
- [Tutorials](#)

© 2017 - 2024 Dokit, SAS.

- [Terms of Use](#)
- [Privacy policy](#)
- [Recent changes](#)
- [Help](#)
- [About](#)