

R0015249 Set drive pinions in position

Instructions to correctly set drive pinions into positions on shafts

 Difficulty **Medium**

 Duration **1 hour(s)**

Contents

Introduction

Step 1 - Unless otherwise stated

Step 2 - Set shaft position

Step 3 - Lock shaft position

Step 4 - Set pinion position

Step 5 - Lock Pinion

Comments

Introduction

Tools Required

Standard Hex key set

Parts Required

none

Step 1 - Unless otherwise stated

Use Loctite 243 on all fasteners

Use Loctite 572 on all threaded pneumatic connections

Pen mark all fasteners to show finalised



Step 2 - Set shaft position

- Each pair of shafts that are joined together can be moved in the directions show to give the optimal contact on keys and drive pinions
- Take all 9 arm positions into consideration and position each shaft accordingly to achieve the best overall position to suit all arms
- Pinion lock points should always be above keyways

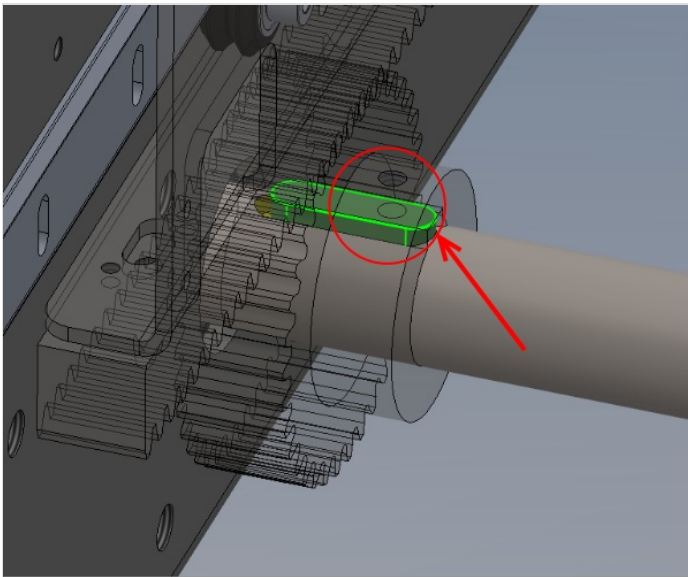
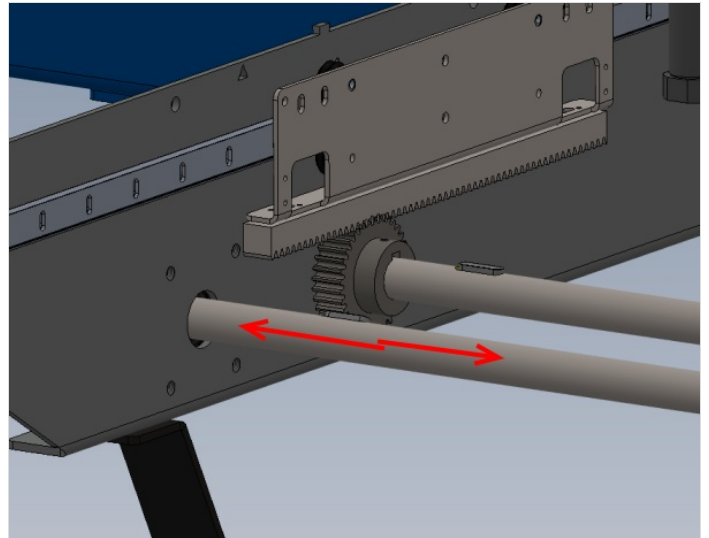
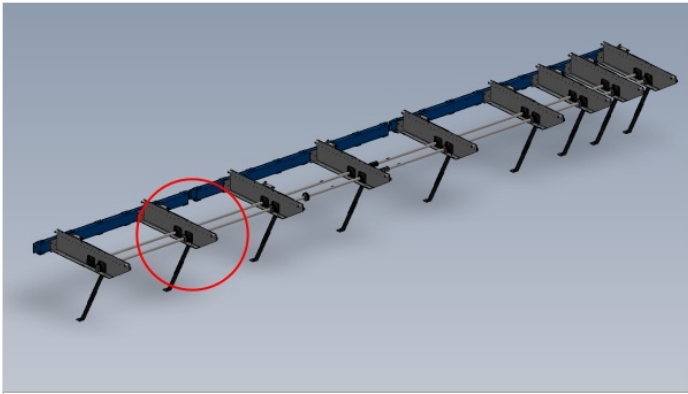

Step 3 - Lock shaft position

Individually remove and apply Loctite 243 to all grub screws on spherical bearings.

2 off grub screw per bearing

18 off bearing

36 off grub screw in total

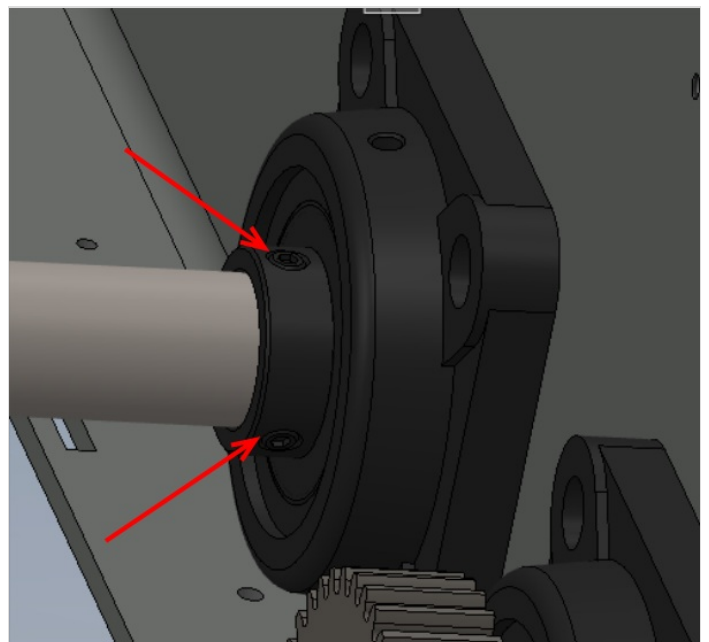

Step 4 - Set pinion position

9 off pinions can now be set in position and finalised
Set position of pinion to achieve as much contact as possible with drive rail, without contacting side of support arm

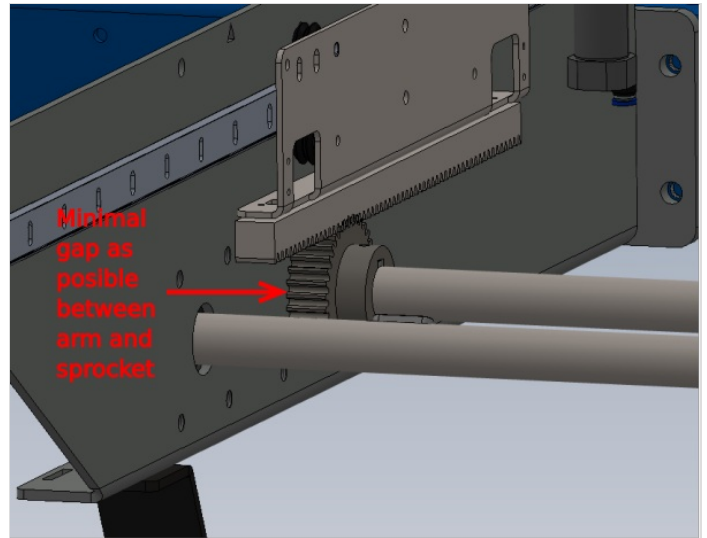

Step 5 - Lock Pinion

lock each pinion in position as follows.

M6 x 10 kcp Grubscrew in hole that contacts key on shaft

M6 x 10 flat bottomed grubscrew on fixing hole that contacts directly onto shaft

