

R0015248 Line up slider units and mesh racks

Instructions to align slider units and mesh racks

 Difficulty **Hard**

 Duration **6 hour(s)**

Contents

Introduction

Step 1 - Drive pinion mesh setting

Step 2 - Check for interference

Step 3 - Set mesh

Step 4 - Repeat

Step 5 - Alignment

Step 6 - Set First and last position

Step 7 - Set Wire line

Step 8 - Adjust Remaining slide units

Step 9 - CAUTION!!!

Step 10 - Fit rack stop one D0015626-OH

Step 11 - Fit rack stop 2 D0015626

Comments

Introduction

Tools Required

Standard hex key set

Stubby hex key set

Wire line

Quick clamps

P0000501 non return valve x 3

Standard HSS drill set

Standard tap set

Tape measure

300mm rule

Parts Required

D0015625 x 1

D0015625-OH x 1

E0000336L x 2

Step 1 - Drive pinion mesh setting

Mesh requires setting between slider unit and drive pinion

1 It is vital that the correct drive meshing is achieved.

2 Once set, there should be 1mm movement in the direction shown, which will indicate the correct tooth meshing has been obtained.

3 This need to be checked at all points of travel as shown

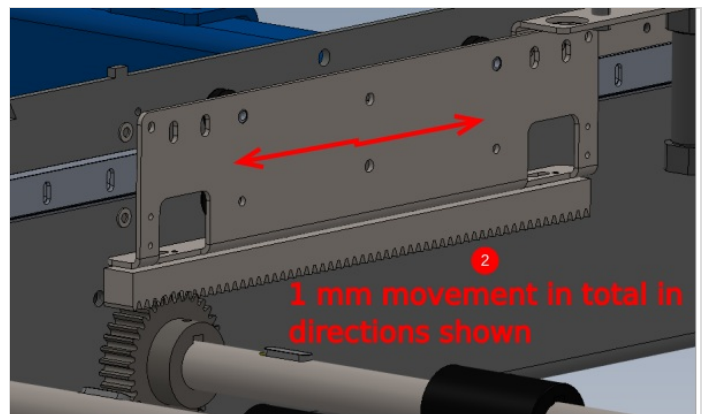
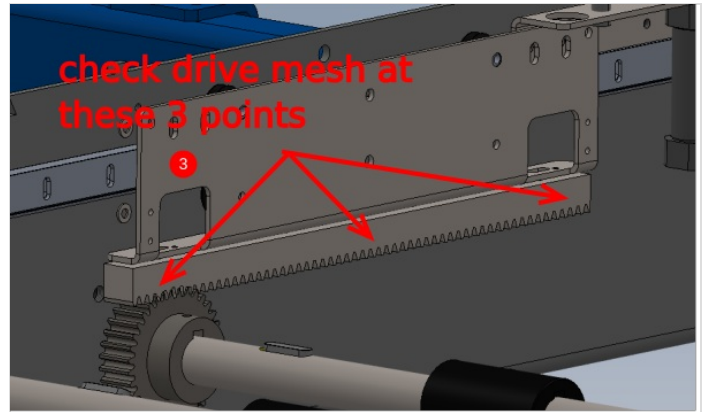
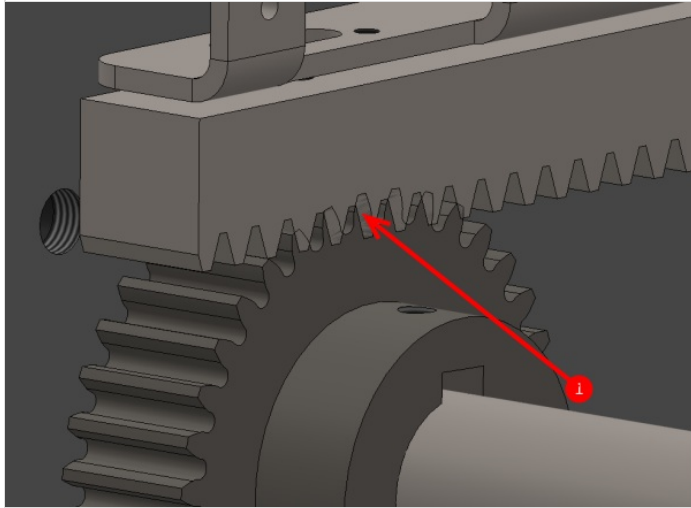

Step 2 - Check for interference

Once drive rack has been meshed, it is vital to check that clearance is present between rack and fixing for bearing block.

Area shown should be checked for clearance, if the fastener hits the drive rail, it should be spaced back with an M10 A form washer on the indicated face to give clearance.

This must be checked on all drive racks

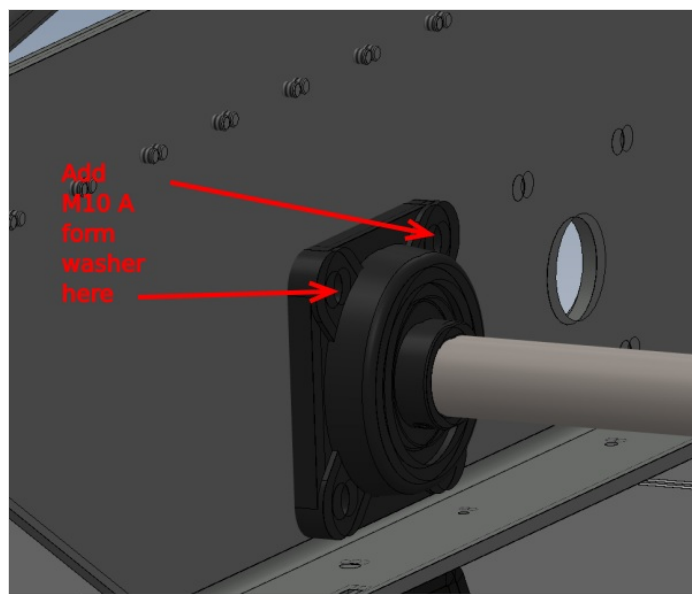
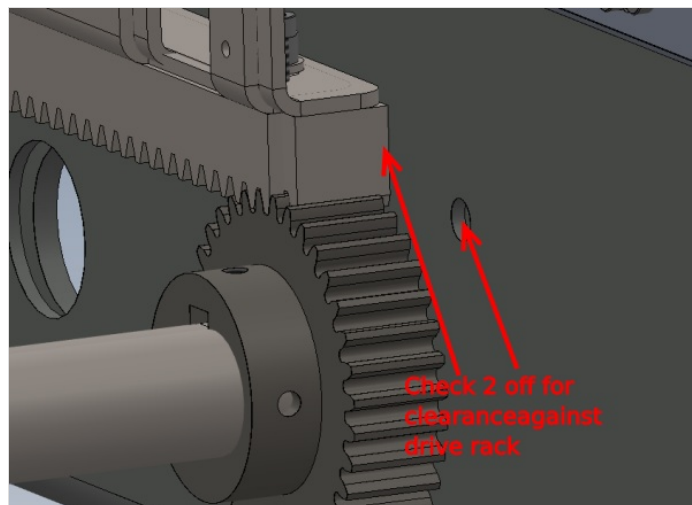
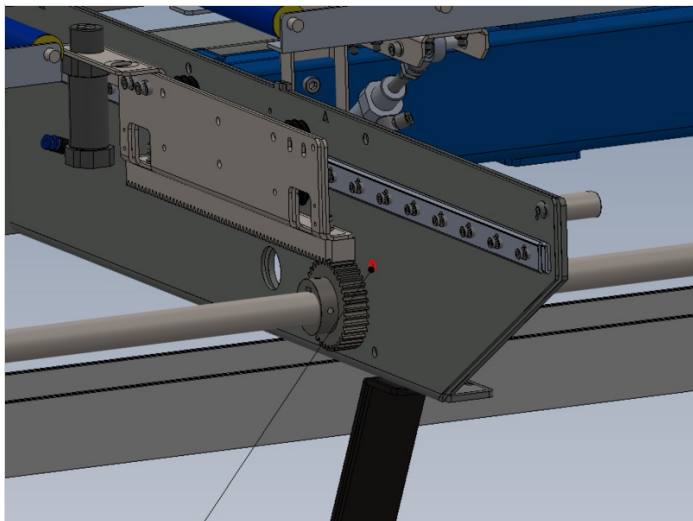

Step 3 - Set mesh

- 1 Slide drive pinion into position 1 under drive rack
- 2 Use M4 adjuster screws to adjust height of rack and M6 to secure
- 3 Slide out drive pinion and move rack to position 2. Refit drive pinion
- 4 Use M4 adjuster screws to adjust height of rack and M6 to secure
- 5 Repeat steps until correct meshing is present at all points indicated to check

Do Not glue any of the M4 /M6 socket caps used for adjustment as this will be done at a later stage

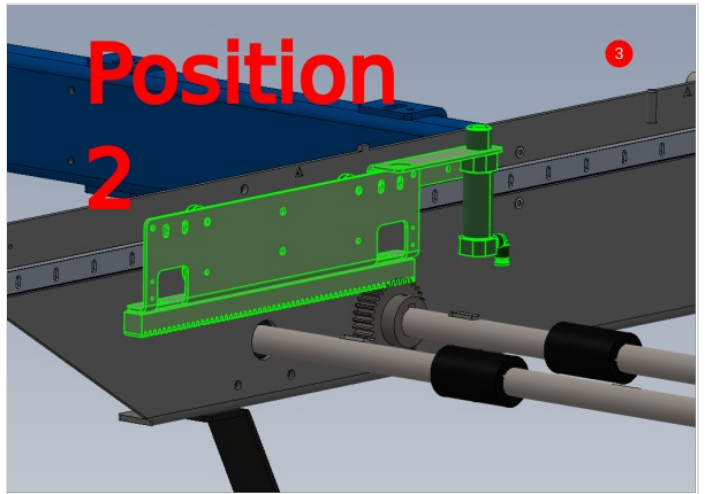
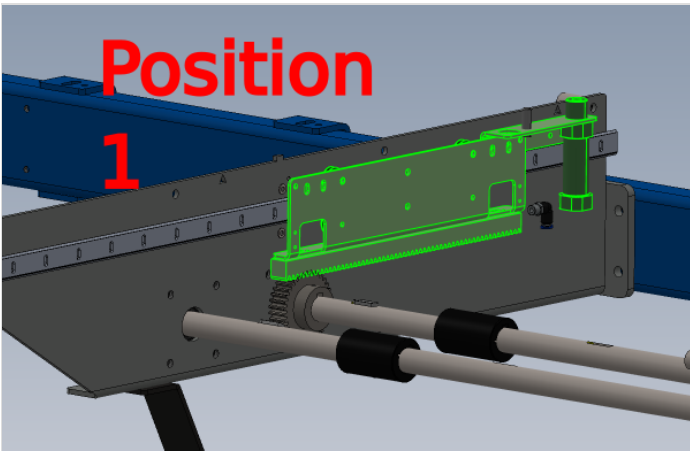
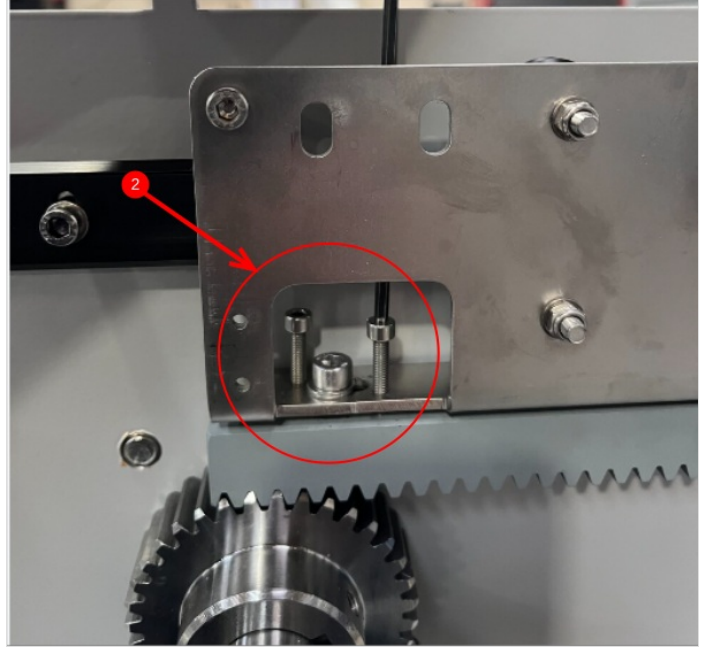
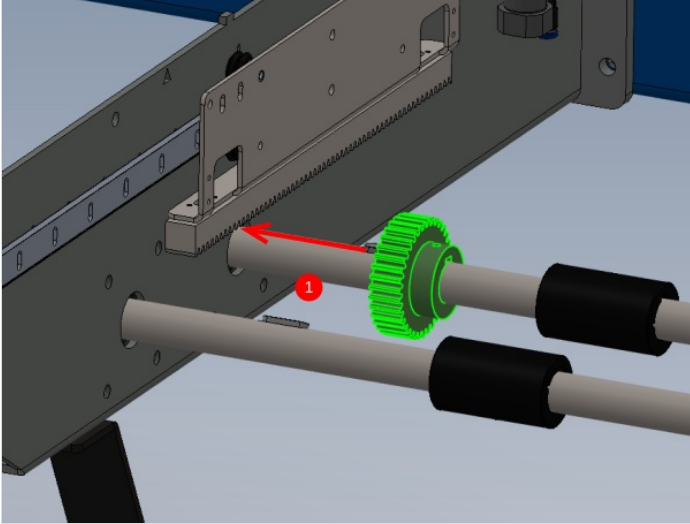

Step 4 - Repeat

Repeat step two for remaining 8 slider units

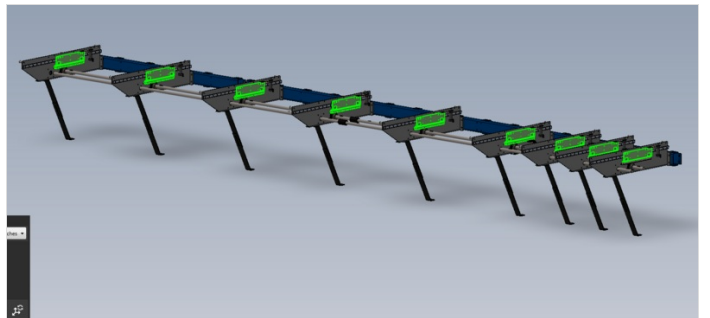

Step 5 - Alignment

Alignment of cylinder pins is vital, and the following should be maintained

1 Alignment should be parallel to main hepco beam

2 Alignment should be Straight

To achieve this the following steps are required

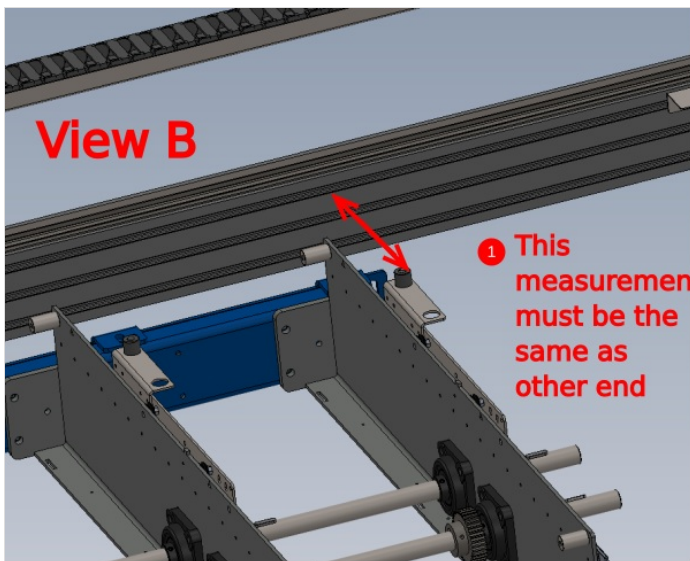
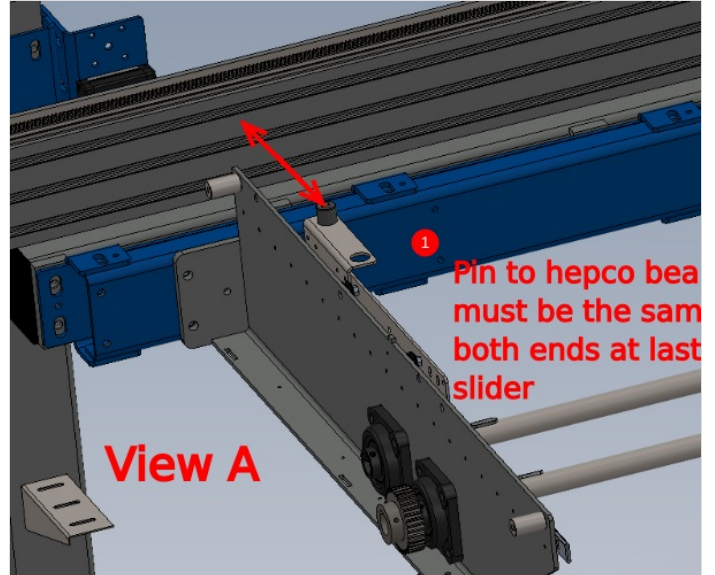
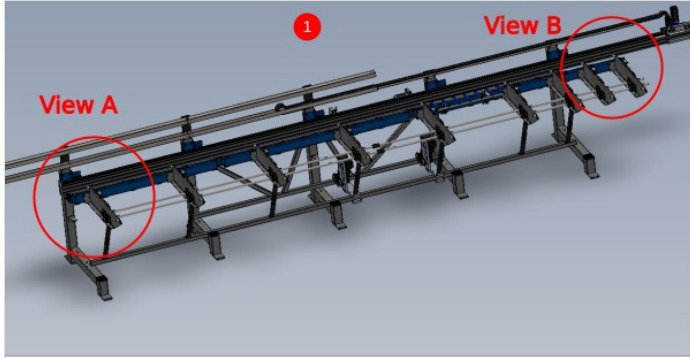

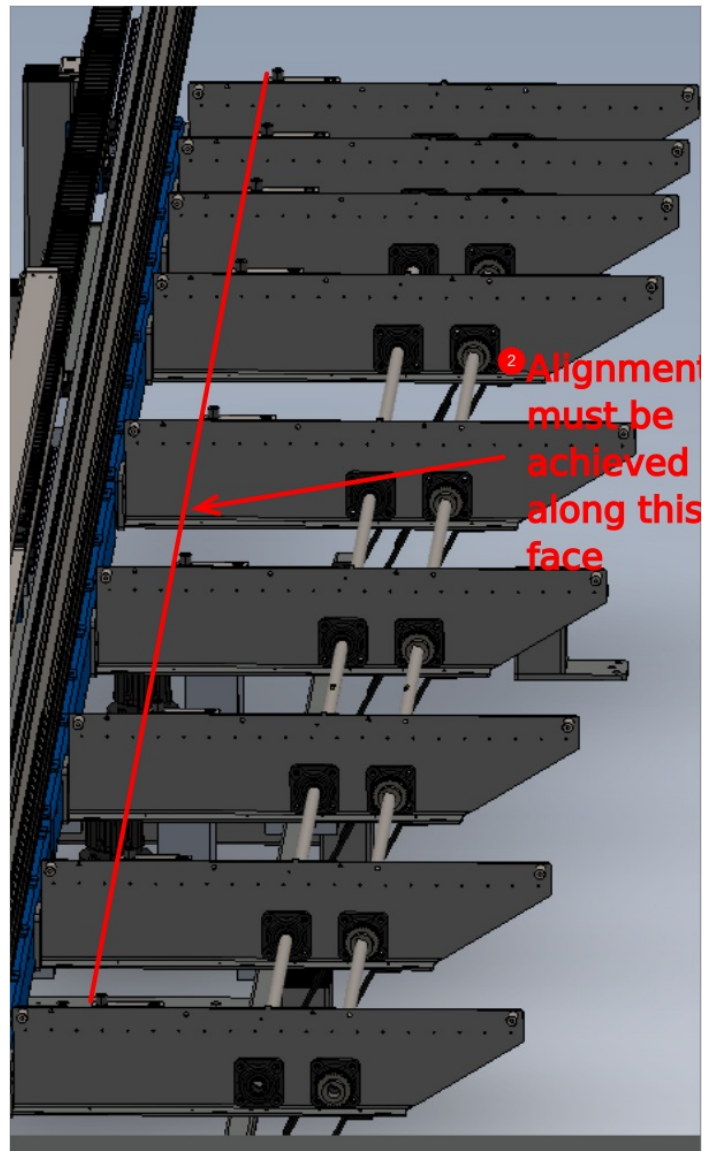

Step 6 - Set First and last position

1 Set First and last slider into the position shown to align indicated hole with fixing point on support arm. Slide pinion into position once slider has been moved to correct point.

2 Fine adjustment can be gained by Removing tension off M6 bolt on drive rail , and using slot to change position of drive rail mounting . Use Socket cap bolt to lock position onto support arm

3 Check measurement between pin and hepcos beam on both sliders to ensure they are the same.

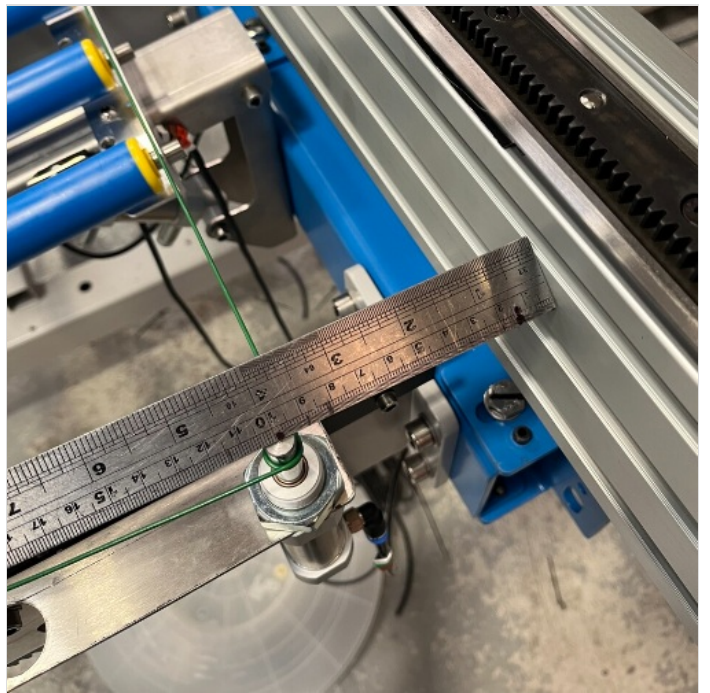
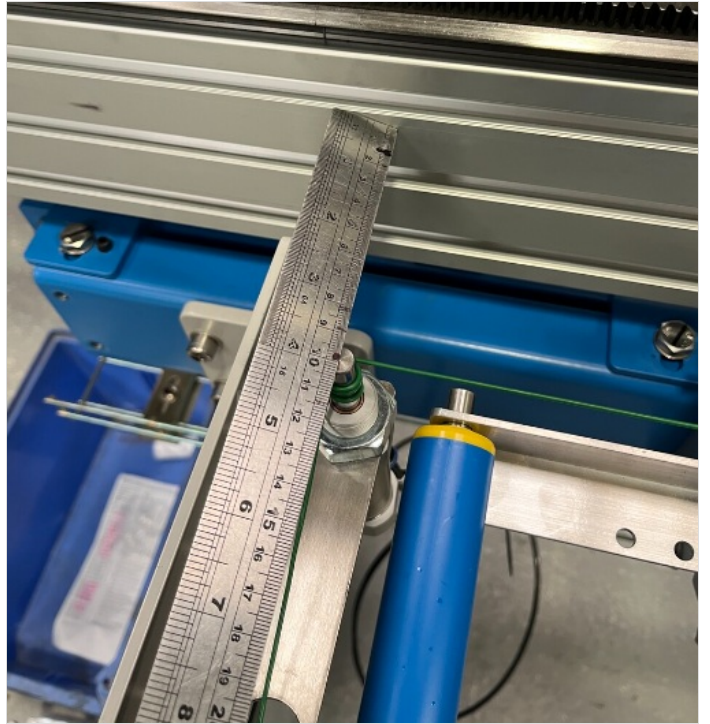
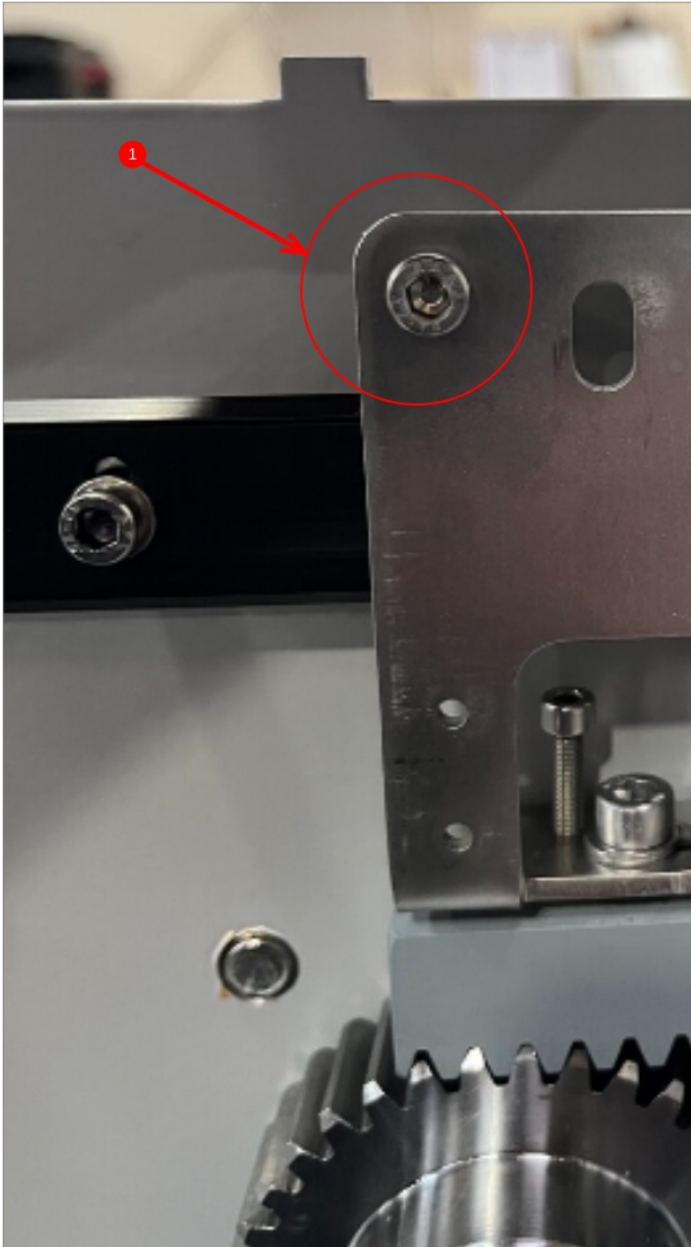

Step 7 - Set Wire line

Use dokit correct use of wire line to ensure alignment is completed correctly

1 Attach P0000501 non return valve with 6mm pipe to first and last cylinder and purge with air to maintain active position of cylinder.

2 Set wire line between these two active cylinders

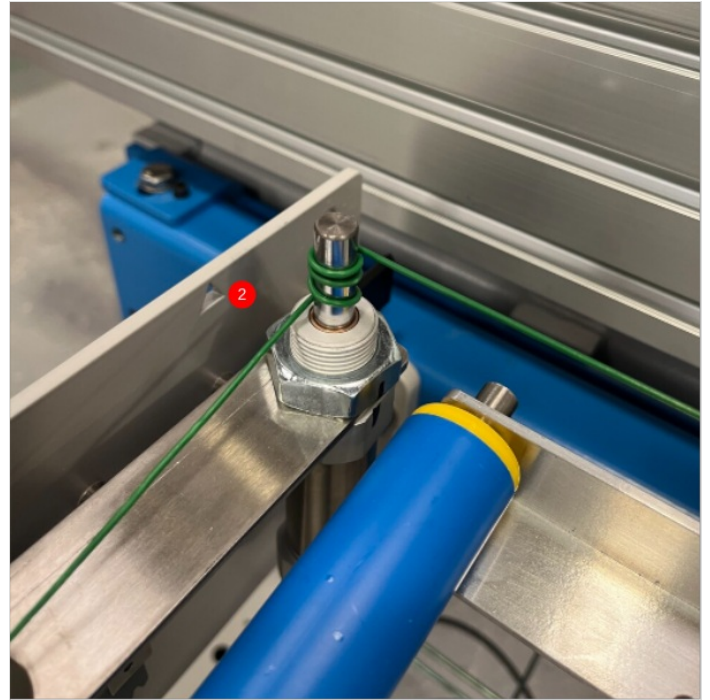
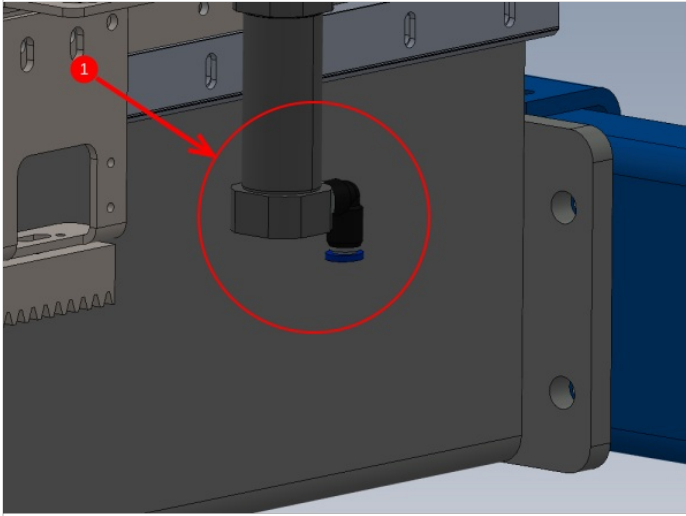

Step 8 - Adjust Remaining slide units

Remaining slide units now need adjusting to align to the wire line . Adjust one at a time, and use a P0000501 non return valve and 6mm pipe to purge each cylinder as you work on it. Once a cylinder is set, remove non return valve and place on next cylinder being set

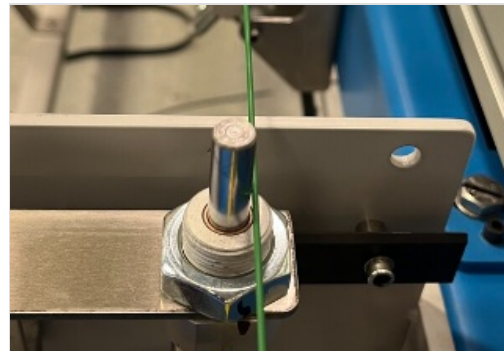

Step 9 - CAUTION!!!

⚠ ...Until rack stops are fitted, it is possible to over position slide units and they will run off drive pinions, and loose all settings previously set. Take care and follow good practice



Step 10 - Fit rack stop one D0015626-OH

1 Assemble one off D015625 and 1 off D0015625 -OH as shown using a M6 x 25 hex set bolt and 2 M6 nuts.

2 Rotate drive shaft to position rack as show

3 Position rack stop as shown and mark, drill and tap to M6. Ensure M6 hex set bolt is set as shown for maximum adjustment
Use M6 x 16 socket caps and A form washers to fix

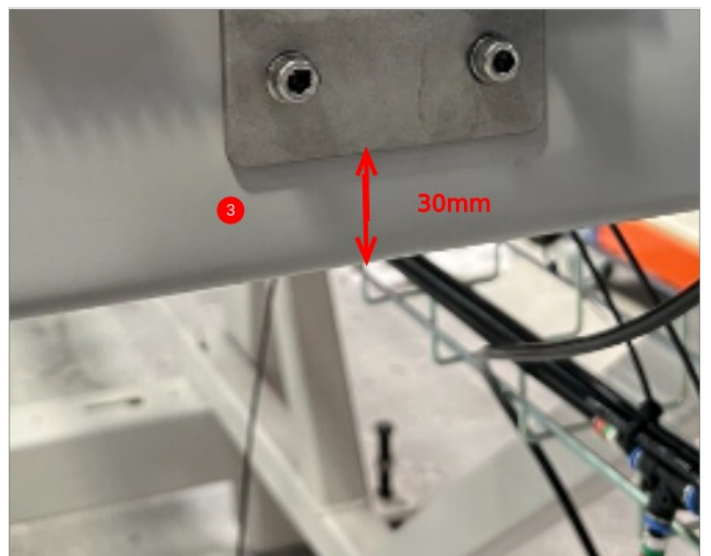
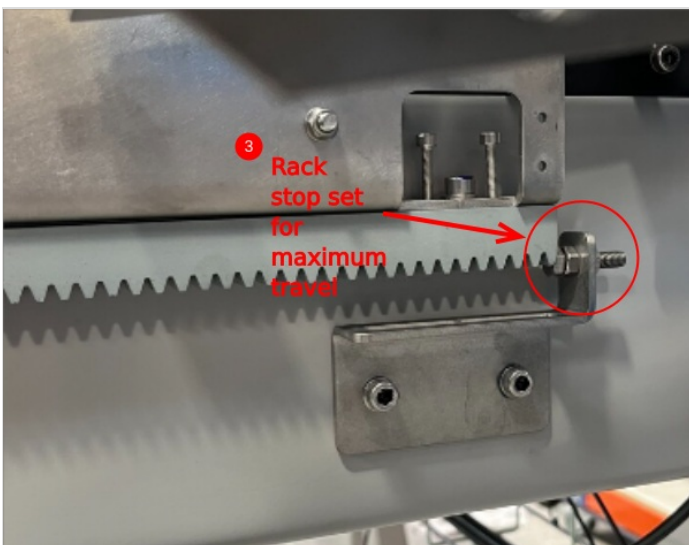
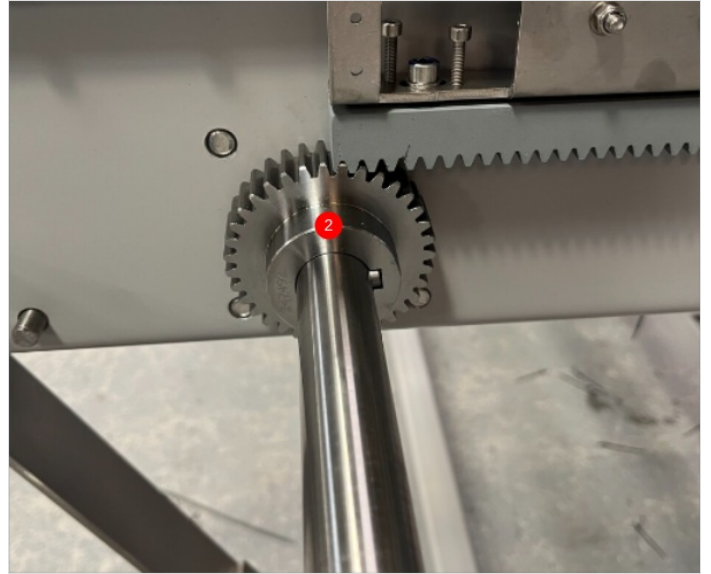
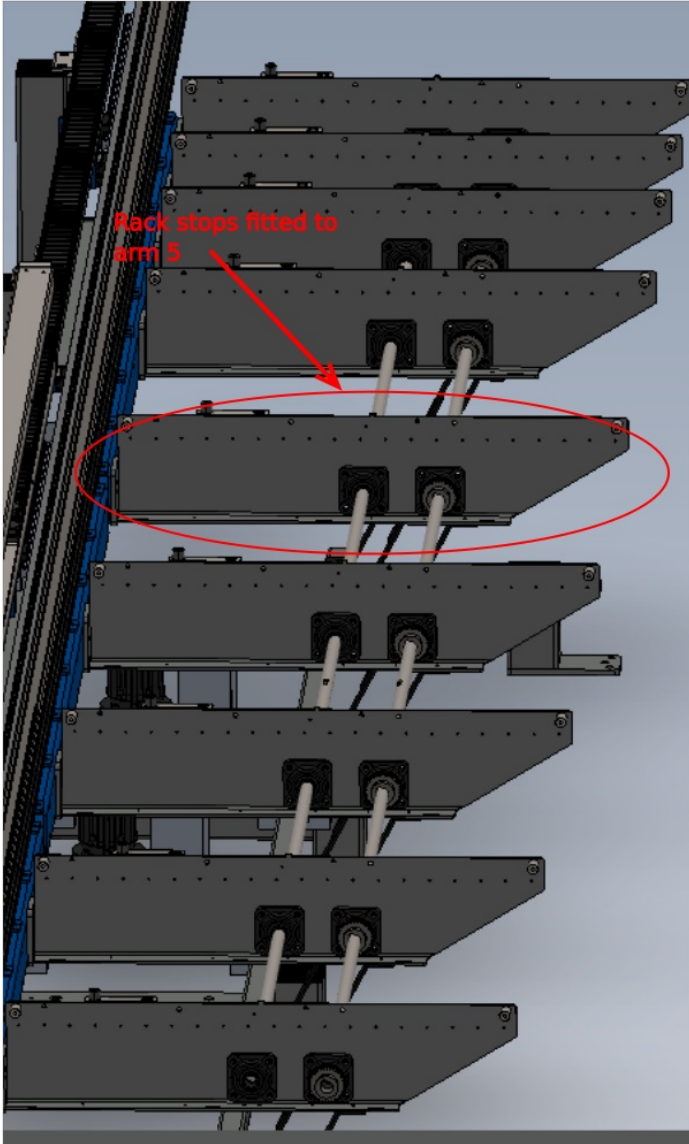

Step 11 - Fit rack stop 2 D0015626

1 Use assembled rack stop from previous step

2 Rotate drive shaft to position rack as show

3 Position rack stop as shown and mark, drill and tap to M6 . Ensure M6 hex set bolt is set as shown for maximum adjustment
Use M6 x 16 socket caps and A form washers to fix

