

R0015090 Bench Assemble Roller Tables

Instructions for bench assembling Roller tables

 Difficulty **Medium**

 Duration **6 hour(s)**

Contents

Introduction

Step 1 - Unless otherwise stated

Step 2 - Assemble Cylinder assembly

Step 3 - Check for rework

Step 4 - Check for rework of following parts

Step 5 - Fit bushes and mount cylinder

Step 6 - Combine support arm and roller bracket

Step 7 - Prepare M3 holes

Step 8 - Process amendment

Step 9 - Assemble Large roller Table

Step 10 - Fit rollers

Step 11 - Assemble medium roller table

Step 12 - Assemble small roller table using pre drilled assembly

Step 13 - Pneumatic pre assembly

Comments

Introduction

Tools Required

Standard Hex key set

Standard spanner set

Tape measure/Rule

8.2mm HSS drill

Drill

Parts Required

P0001110 x 13

P0000049 x 13

P0001198 x 26

D0015001 x 13

B0001103 x 26

D0015481 x 13

B0001220 x 26

D0015603 x 13

D0015010 x 26

D00150002 x 13

D0015603 x 13

D0015005 x 10

B0001092 x 45

D0015004 x 2

D0015003 x 4

D00155547 x 1
E0001120 x 1
P0000200 x 1
P0000160 x 1
P0001030 x 10

Step 1 - Unless otherwise stated

Use loctite 243 on all fasteners

Use loctite 572 on all threaded pneumatic connection

Pen mark all fasteners to show finalised



Step 2 - Assemble Cylinder assembly

!Ensure Fixing nut from indicated point is removed from each cylinder and disregarded

13 off

i ...All Flow regulator fittings P0001198 should be set at this point to the correct flow rate. To do this follow these steps
1 Wind regulation screw clockwise until fully in. Do not overtighten, stop when light resistance is felt.
2 Turn regulation screw exactly 2.5 turns anticlockwise to set flow rate

1 Fit 2 off P0001198 fittings to cylinder P0001110

2 Fit spherical bearing P0000049 to cylinder end , Do not add final tension to the nut

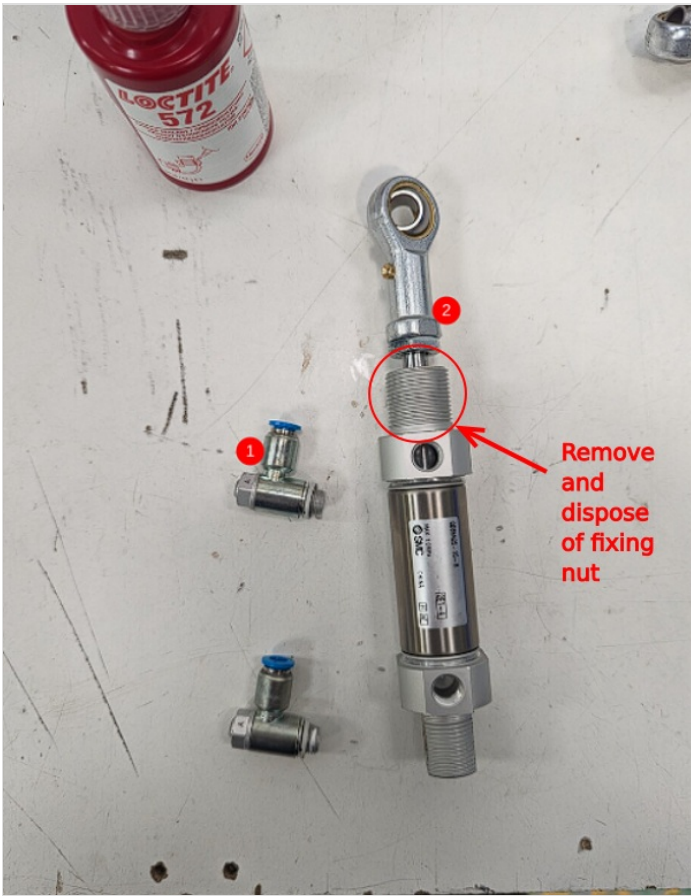

Step 3 - Check for rework

13 off

Check part D00150001 has been supplied to new specification
Check indicated hole, should measure 8.2mm. If not open up with
hand drill
Drawing change requested 06/06/23 to amend from 8mm to
8.2mm



Step 4 - Check for rework of following parts

1 D0015006B indicated holes should measure as shown. Rework by hand if issued old spec
ECR raised 06/06/23

2 D0015002 rod end shaft . Check fit in P0000049 spherical bearing . Polish down diameter to allow shaft to pass through.
ECR raised 06/06.23 to improve tolerance of shaft to allow better fitment

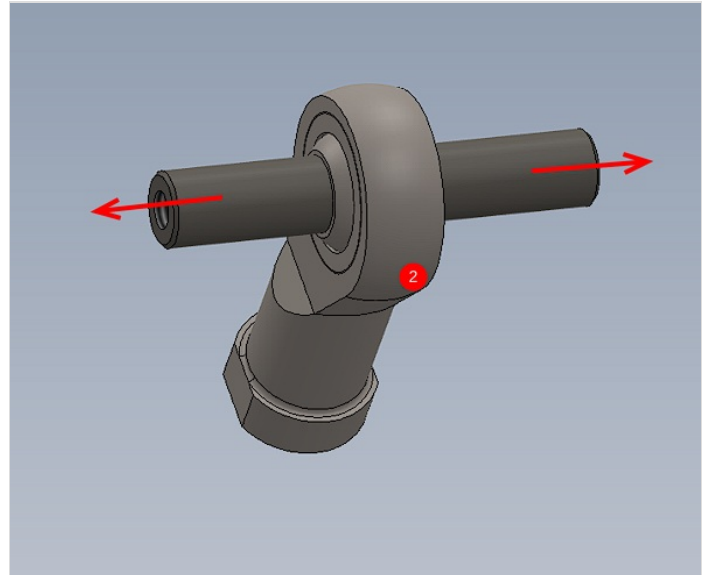
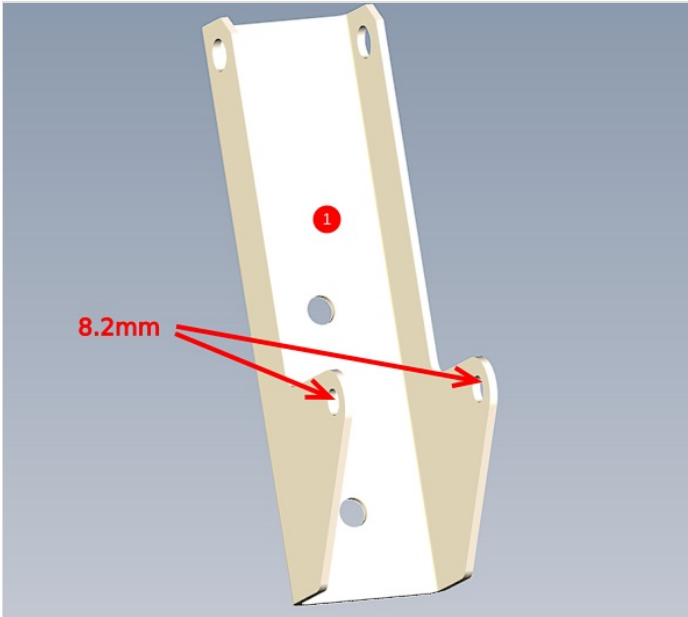

Step 5 - Fit bushes and mount cylinder

13 off

1 Combine D0015481 shaft and B0001220 spacer as shown to mount cylinder to bracket. Use M6 x 12 socket caps and A form washers to fasten

2 Fit 2 off B0001103 bushes to D0015006B

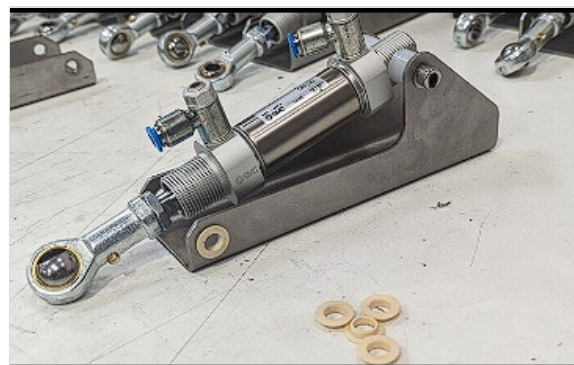
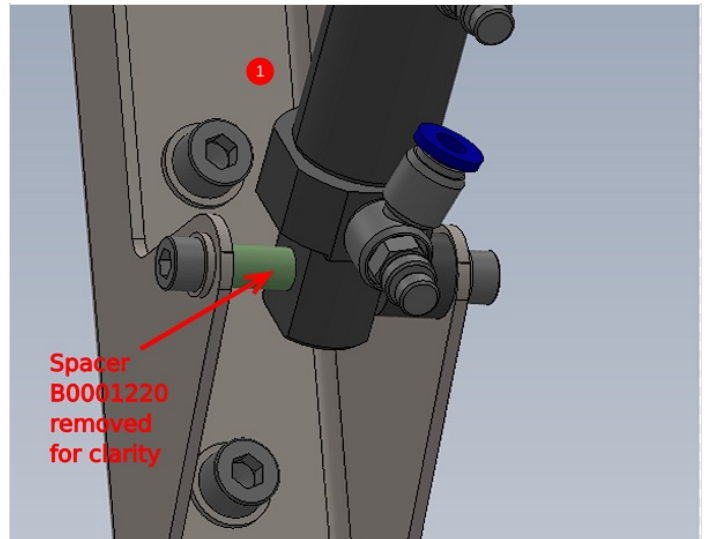
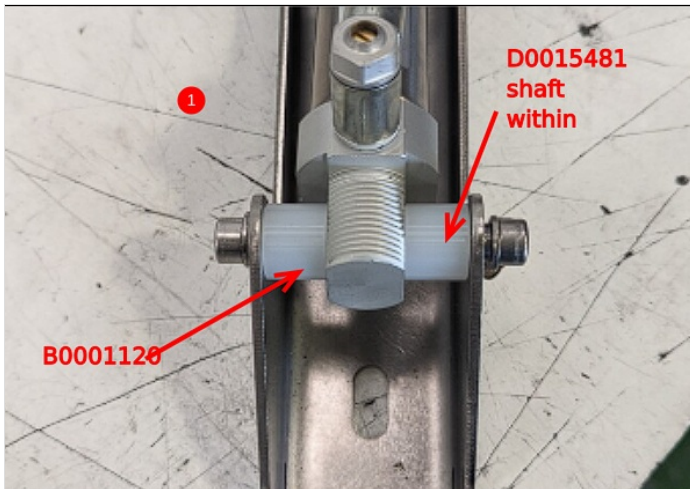

Step 6 - Combine support arm and roller bracket

13 off

1 Fit 2 off D0015010 spacers, 1 off d0015002 shaft through spherical bearing and fix with 2 off m6 X 12 socket caps and A form washers

2 Fit 1 Off D0015603 pivot shaft with 2 off M6 x 12 socket caps and A Form washers

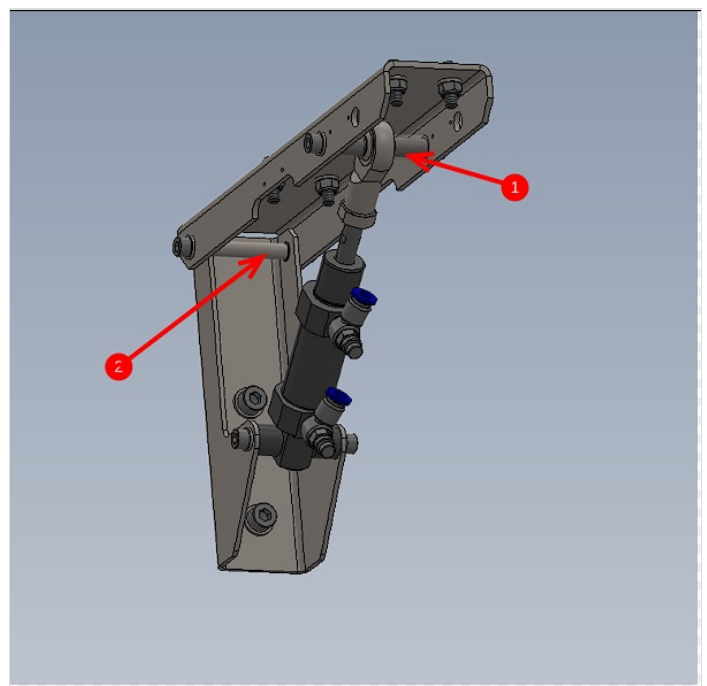

Step 7 - Prepare M3 holes

1 off only and mark for later Reference

Tap 2 off indicated holes M3

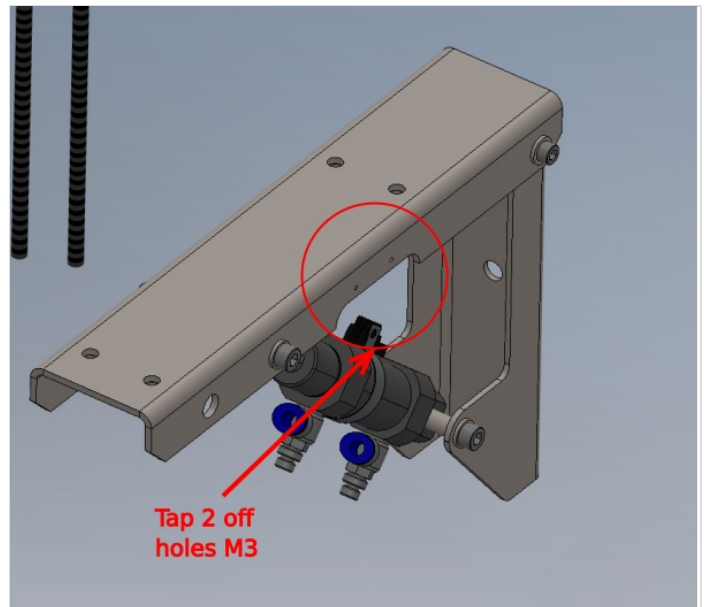

Step 8 - Process amendment

Process for bench assembly of roller beds has been amended to aid fitment later on in build process.

Once roller beds are assembled, connection between cylinder and rod end bearing should be disconnected

Please take pictures of this please

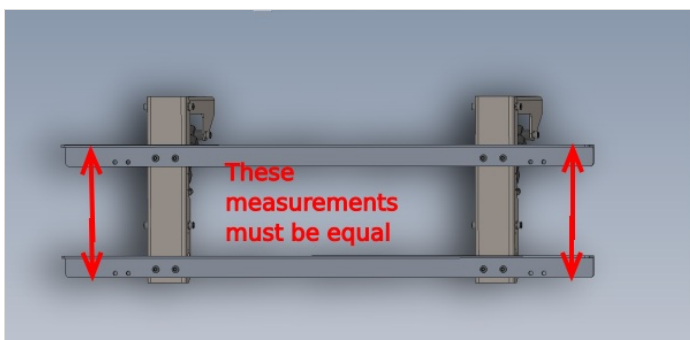
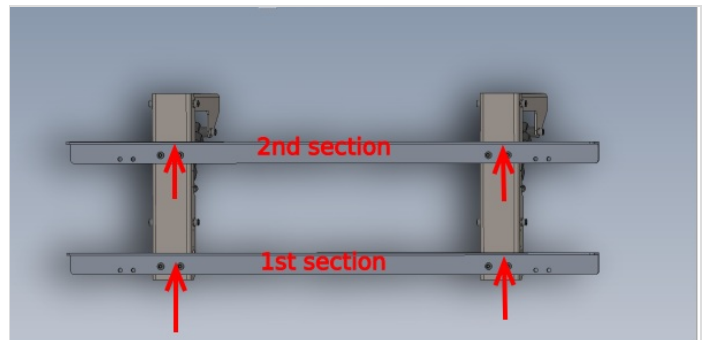
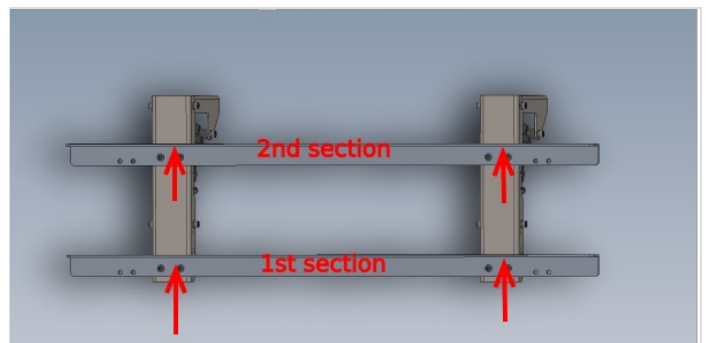

Step 9 - Assemble Large roller Table

5 off to be assembled

1 Mount 2 off D0015005 to prebuild cylinder assemblies as shown

Use M6 x 20 button socket , A form washer and M6 nyloc nuts to fix.

Do not use washer under head of button head screw, on use on on nut side

2 Adjust the 2 off D0015005

1st section pushed against edge of clearance hole in direction shown

2nd section pushed in same direction

3rd Check parallel and adjust to correct

4th check squareness by taking corner measurements and adjusting if required

Once all above is achieved, finalise fasteners

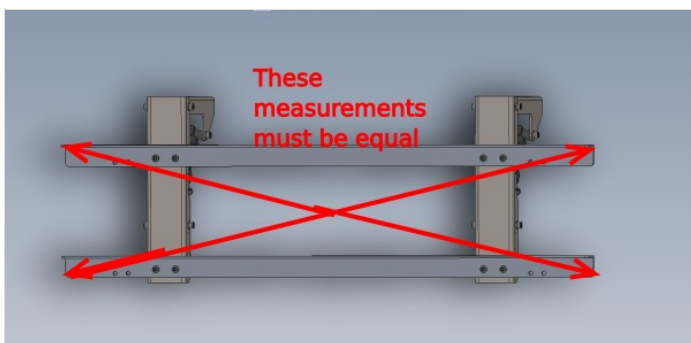
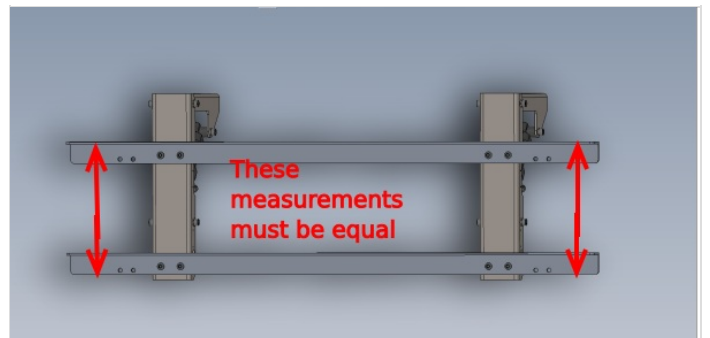
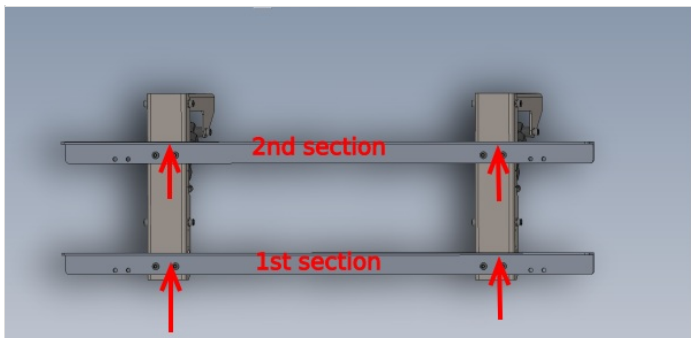
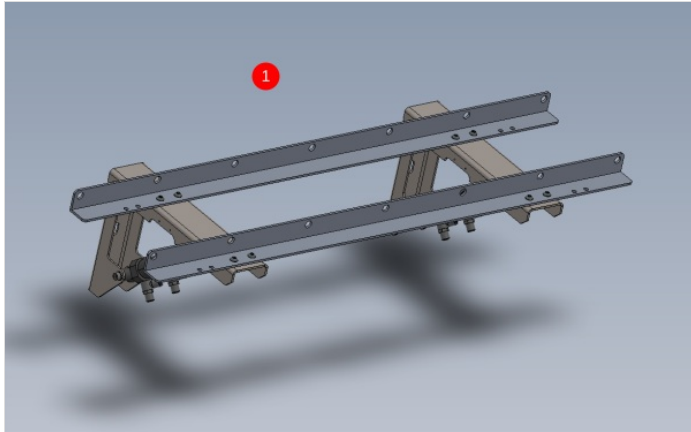

Step 10 - Fit rollers

Fit 3 off B000102 roller to each assembly

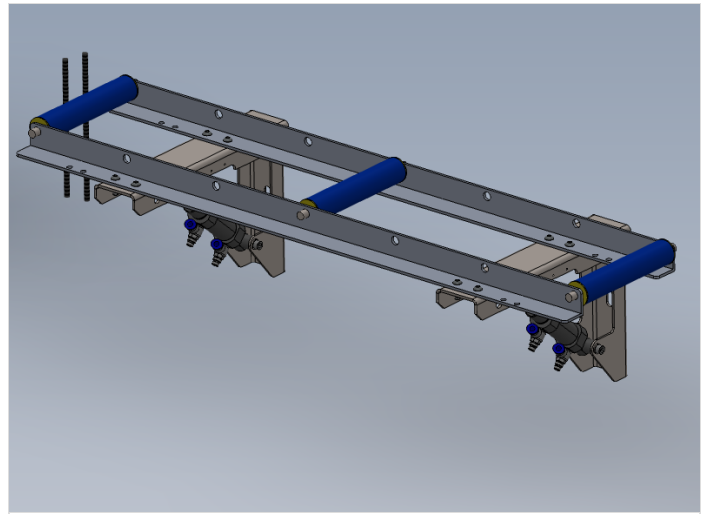

Step 11 - Assemble medium roller table

Using same checks and setting as above assemble 1 off roller table with 4 rollers as shown

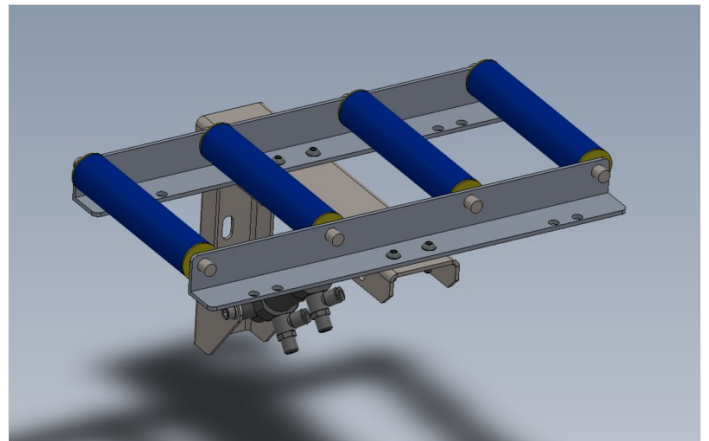

Step 12 - Assemble small roller table using pre drilled assembly

1 Using same checks and setting as above assemble 2 off roller tables with 4 rollers as shown,

Use the pre built cylinder bracket with m3 tapped holes for 1 off, and add 1 off Sensor E001120 ,1 off Blower P0000200 , 1 off P0000160 flow regulator and 1 off bracket D0015547 as shown. Label as 3759

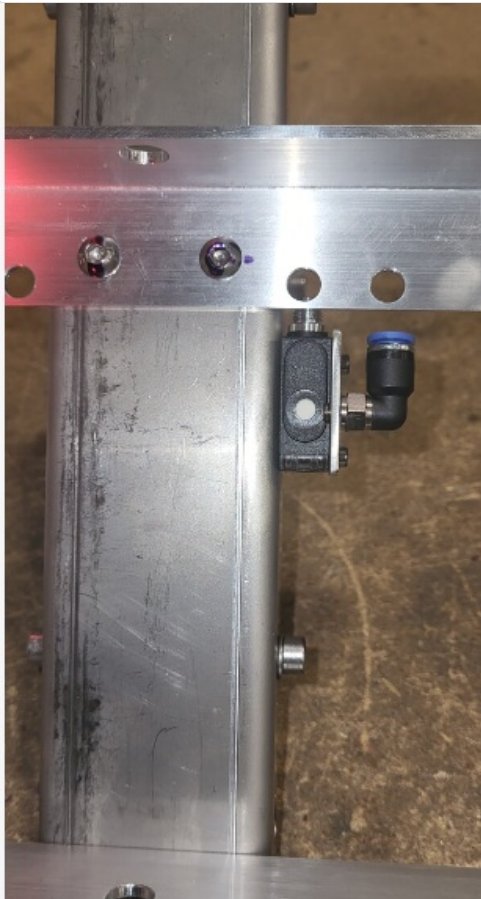

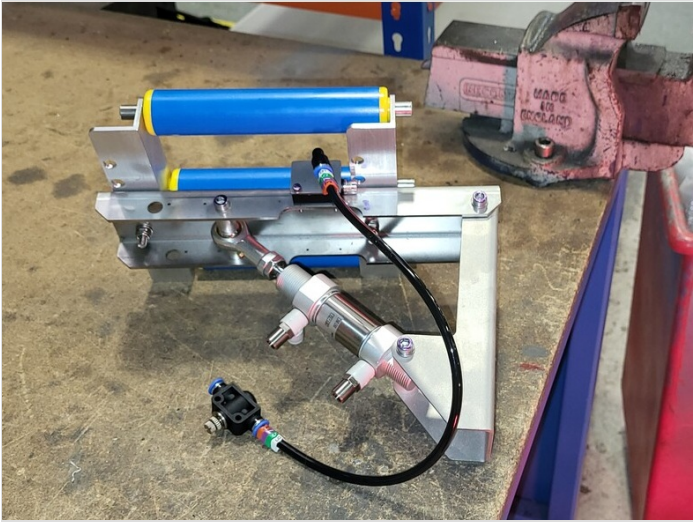
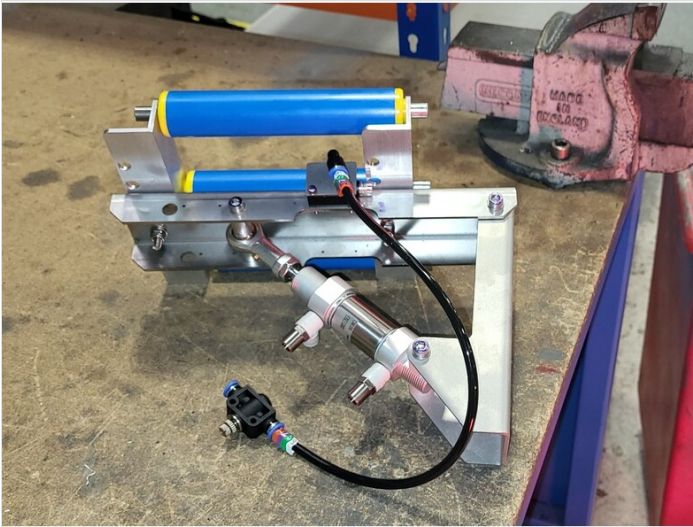
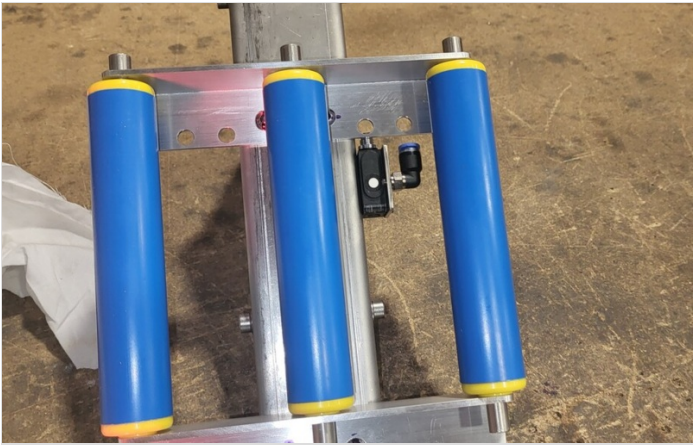

Step 13 - Pneumatic pre assembly

5 off

Large Roller bed assemblies with two cylinders require pneumatic pipe installation.

Use identification numbers as follows

1571 Home position (up)

1579 Active position (down)

