



R0015264 Fit Loader chains to arms

Instructions to fit loader chains to arms

 Difficulty **Medium**

 Duration **2 hour(s)**

Contents

Introduction

Step 1 - Important amendment added

Step 2 - Unless otherwise stated

Step 3 - 1st stage fix of drive sprockets

Step 4 - Fit chains

Step 5 - Finalise Sprocket fasteners

Step 6 - Tension chains

Step 7 - Fit D0016035 Loading pegs

Step 8 - Double check

Step 9 - Quality check

Comments

Introduction

Tools Required

Standard hex key set

Standard spanner set

150mm rule

Long nose pliers

Loctite 290

Straight ended 4mm hex key and extension bar

Parts Required

Pre assembled R0000699 9off loader chains

Step 1 - Important amendment added

Please note, important amendment added to include details for new style of loading pegs D0016035 and specific fixing required



Step 2 - Unless otherwise stated

Use loctite 243 on all fasteners

Use Loctite 572 on all threaded pneumatic connections

Pen mark all bolts to show finalised



Step 3 - 1st stage fix of drive sprockets

Add M8 x 20 kcp grubscrew to each chain drive sprocket. Do not add adhesive at this point

⚠ ...Warning . Ensure the next step is adhered to. Please read carefully !!!!!

Align sprocket with faces shown and tighten grubscrew ensuring the

******flat on the driveshaft ******

is **aligned** with the fixing grubscrew .

Repeat for all 8 remaining sprockets

⚠ ...Sprocket to chain runner alignment is vital for free running of load system. Ensure faces as shown as item 3 are set correctly

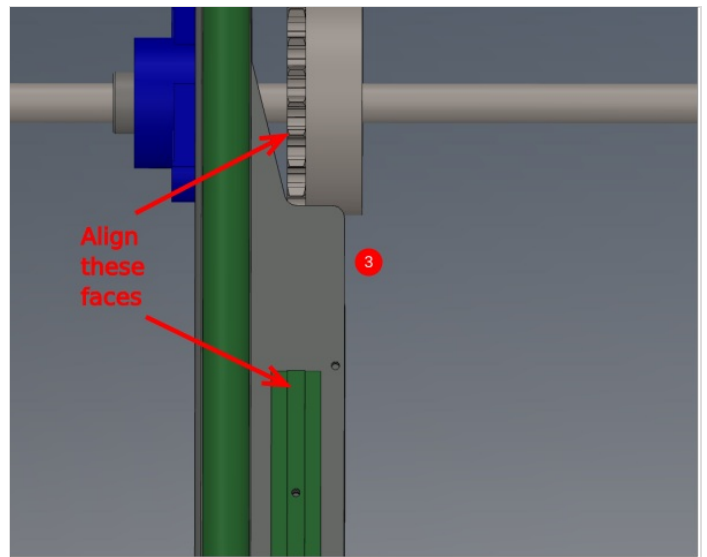
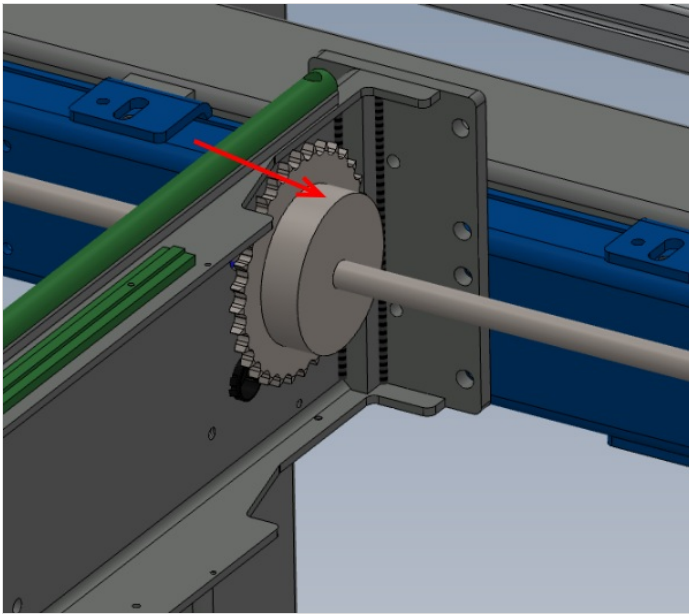

Step 4 - Fit chains

Remove chain joining link from chain assembly and fit chain in position

⚠ ...Ensure drive shaft does not rotate when fitting chains

It is vital all chains are fitted in the same position, to do this

1 When fitting chain use datum point to align chain paddle

2 Attach chain link joiner

Repeat for all 8 remaining chains

If chains are tight to connect adjust M8 set bolt to reduce tension on chains

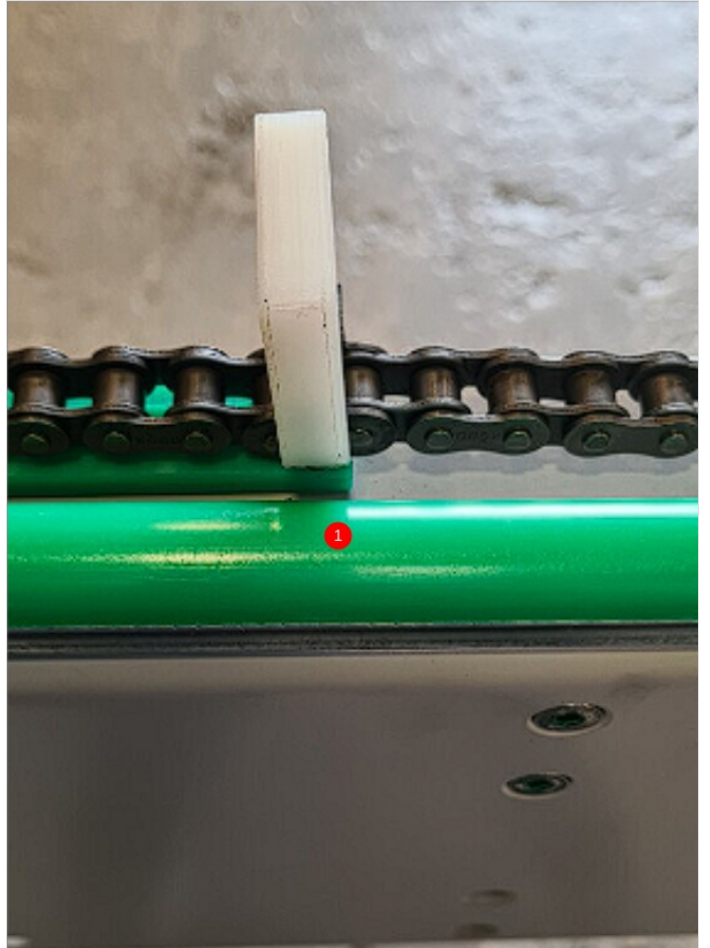
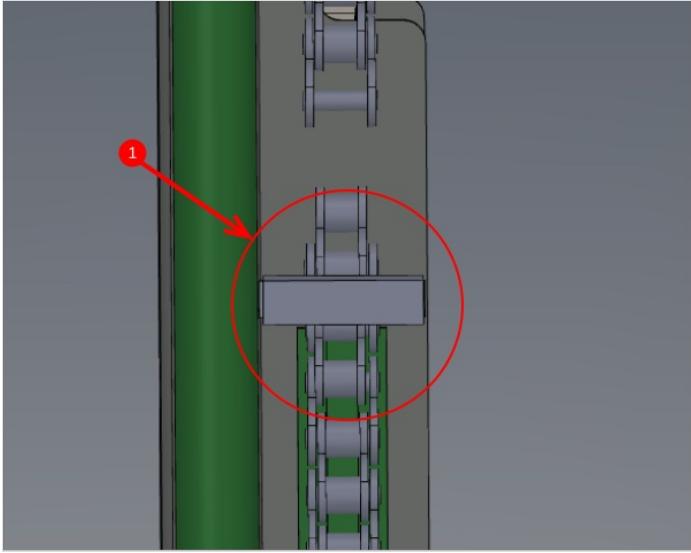

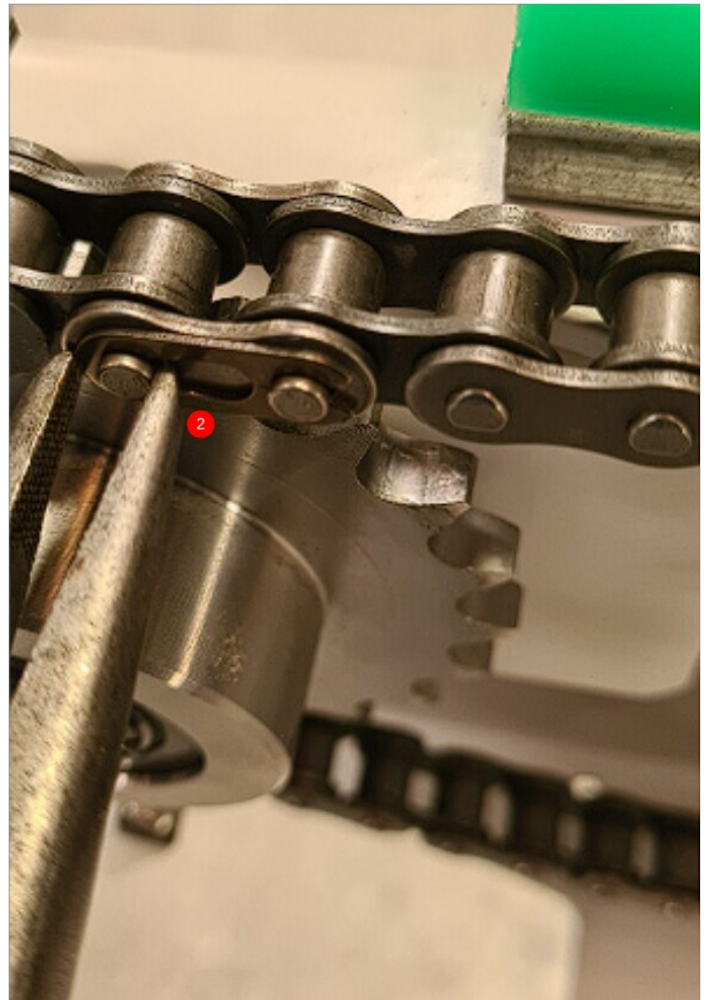

Step 5 - Finalise Sprocket fasteners

It is vital to tension the securing grub screw for the drive sprockets correctly

Use a straight ended 4mm hex key and extension bar to apply as much tension as possible to the m8 grub screw

Then add 2 drops of self wicking thread locker to complete the tension process

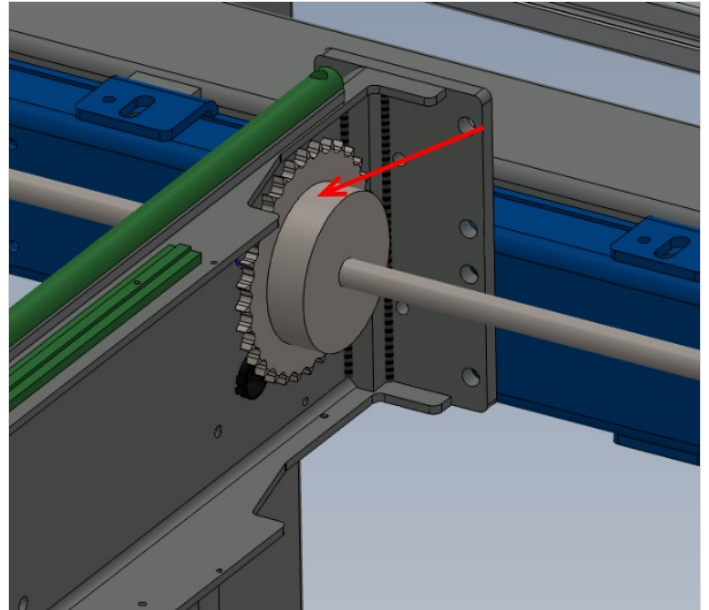

Step 6 - Tension chains

Using the M8 adjusting set bolt, set shown gap to the range shown. (30-33mm approx)

This will give a starting position for chain adjustment

Once set, gauge feel of the chains to note any difference in tension between all chains

Check clearance between bottom flights on chains and bottom of arm

Adjust individual chains to match correctly tensioned chains, and ensure all chain flights are clear from bottom arm face

ALL CHAINS SHOULD BE THE SAME TENSION

Once set, lock off M8 locking nut

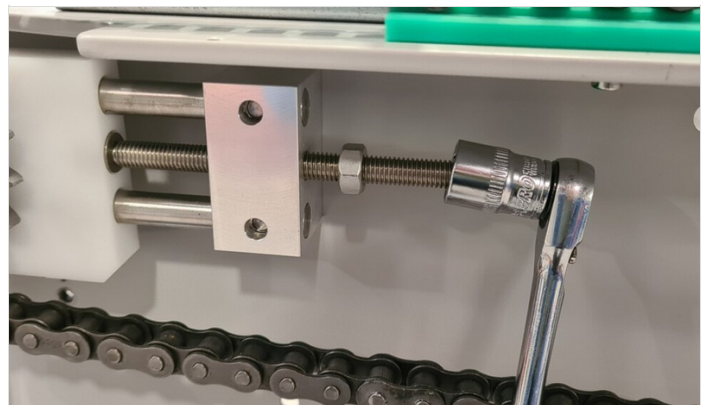
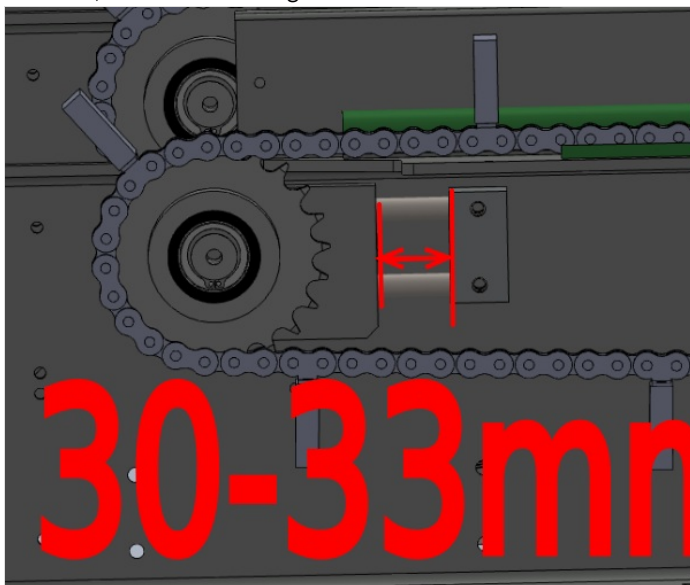



Step 7 - Fit D0016035 Loading pegs

i ...The loading pegs will be fitted in batches to the top facing chain fixing points accessible. Chains must be then rotated to provide access to the next batch of loading pegs to be fitted. Please repeat these steps until ALL loading pegs are fitted and secured

Fitting process for loading pegs

- 1 Fit D0016035 loading peg to chain attachment point
- 2 Insert 1 off 4.2mm self drill screw into position shown to space cavity
- 3 Drill and fix at point shown to drill/screw fixing in and finalise fixing
- 4 Remove spacer screw

A ...Ensure fixing screw is fitted to the same side of all loading pegs on every chain

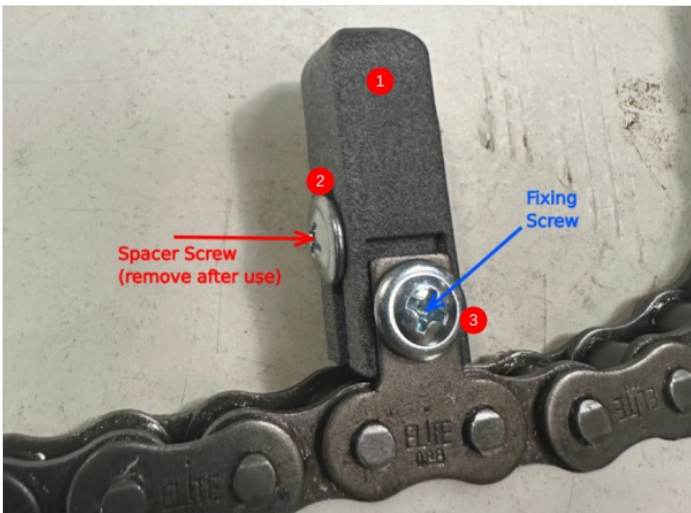

Step 8 - Double check

Double check that ALL loading pegs have appropriate fixings added and none has been missed .

Fully rotate chains to check all pegs



Step 9 - Quality check

1 Once all chains are fitted a visual check should be performed to confirm alignment . When looking over the length of the table, all chain flights should be inline

2 Chain flights should be checked for interference on loading arms. Rotate chains by hand at least one full rotation and check for any clashes between flights and arms in the indicated areas

Report any discrepancies to supervisor for correct remedial action

