

# R0000738 Pneumatic Installation

Pneumatic installation details for ZX5 module B

 Difficulty **Hard**

 Duration **8 hour(s)**

## Contents

Introduction

Step 1 - Unless otherwise stated

Step 2 - Machine Handing

Step 3 - Fit pre assembled valve bank and bracket

Step 4 - Y269 Ring blow output

Step 5 - Y270 Clamp hold

Step 6 - Y350 Clamp infeed top

Step 7 - Y351 infeed side clamp

Step 8 - Y360 work blowers

Step 9 - Y386 Outfeed clamps

Step 10 - Y389 V cut

Step 11 - Y395 Clamps V

Step 12 - 12mm blue connections Ring feed

Step 13 - 12mm blue connections Valve bank supply

Step 14 - 12mm blue connection V cut valve

Step 15 - Rear pipe exit handing

Step 16 - Finalise Blue 12mm ring main

Step 17 - Ring Spindle anti drop valve installation

Comments

## Introduction

### Tools Required

Pipe cutters

Pipe identification numbers

### Parts Required

D0015703 Air Gun Bracket x 1

P0000010 Elbow Adaptor 6mm - 1/8 BSPT (Taper thread) x 2

P0000046 Fitting: 'Y' Adaptor 6mm x 4

P0000053 6mm T (P16) x 2

P0000075 Parallel Y Connector 8mm x 1

P0000077 Straight Adaptor 8mm - 1/8BSP x 3

P0000160 Fitting: Flow Controller In Line 6mm x 4

P0000161 Plug-in Reducer 6mm Tube 8mm Fitting x 6

P0000401 6mm inline non return valve x 2

P0000470 Valve: 5/2 PnPnu 1/8BSP x 1

- P0000513 Ball valve with QS connector x 1
- P0000551 6mm inline Quick Exhaust Fitting x 6
- P0001106 Plug in reducer 12mm to 8mm x 7
- P0001107 12mm Y connector x 8
- R0015114 Bench Assemble Valve banks and Regulators

## Step 1 - Unless otherwise stated

- Use Loctite 243 on all fasteners
- Use Loctite 572 on all threaded pneumatic connection
- Pen mark all fasteners to show finalised



---

## Step 2 - Machine Handing

Exit point of shown pipes changes in respect to hand of machine

Photo shows L-R configuration

For R-L configuration, the pipes must exit the trunking on the left side ( opposite to shown picture)

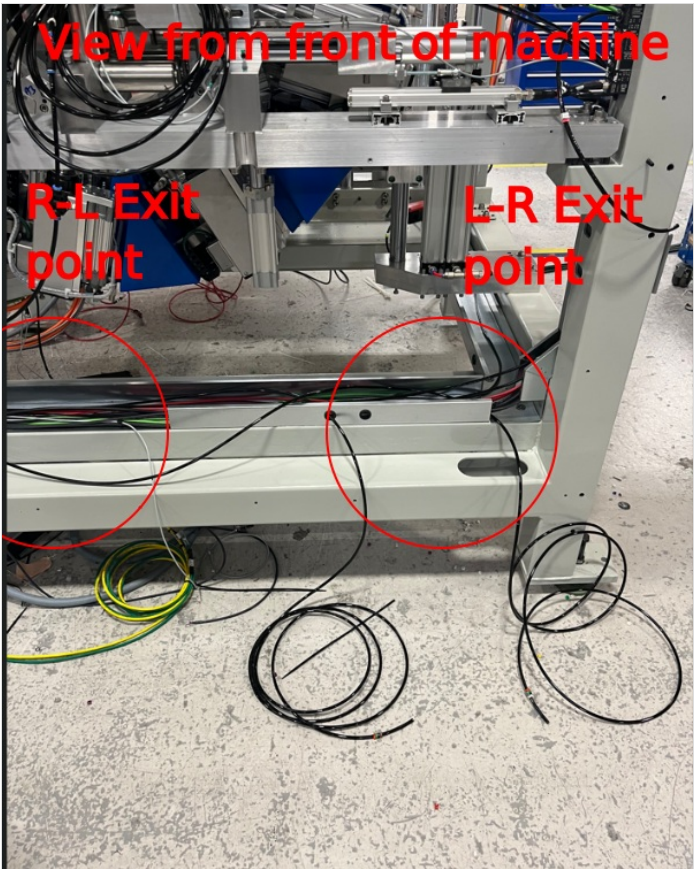

## Step 3 - Fit pre assembled valve bank and bracket

Use 3 off m6 x 12 Socket caps +and 3 off M6 A form washers to fix

Note the position shown is correct for L-R and R-L machines

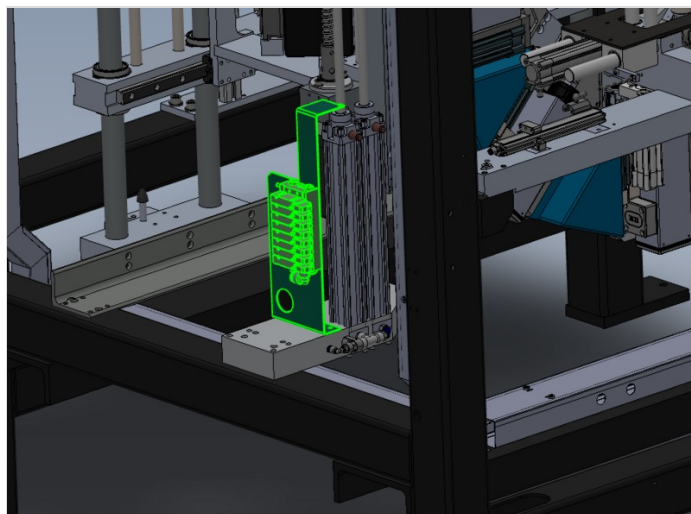
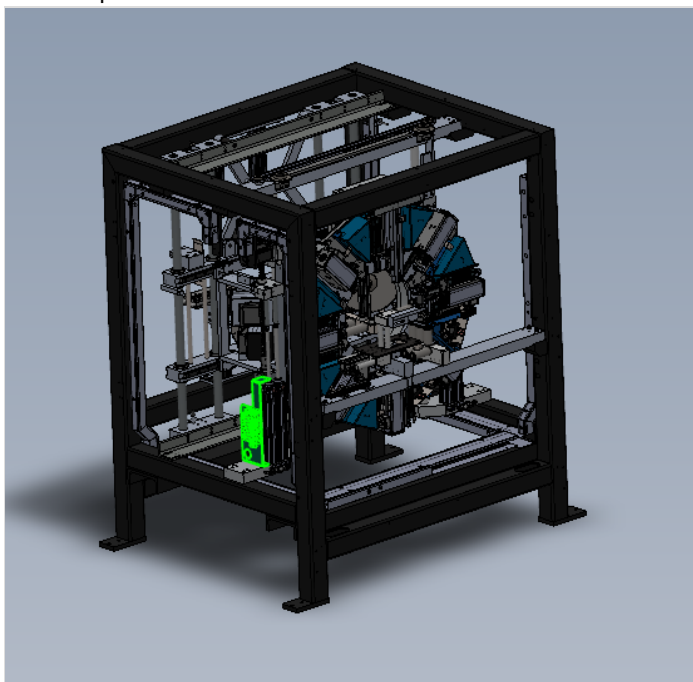

## Step 4 - Y269 Ring blow output

Pipe id 2699

Pipe trailing from rotary head energy chain  
Route into trunking and exit as shown to valve bank

Blank port 2



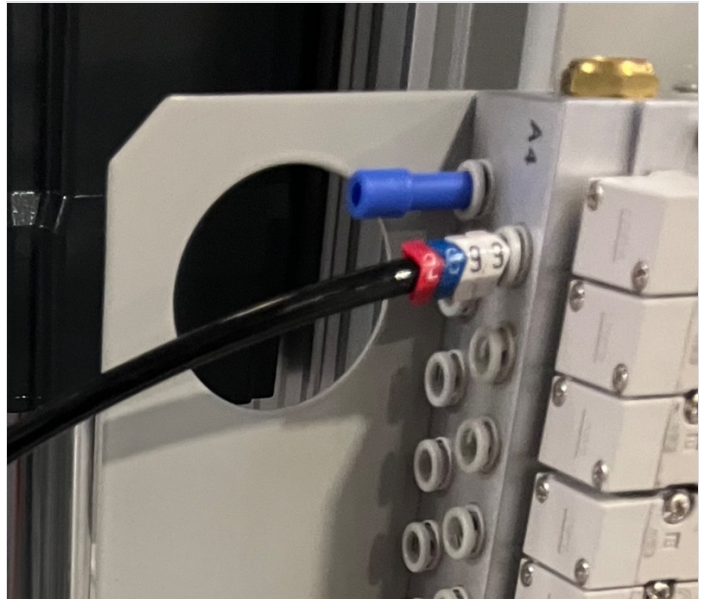
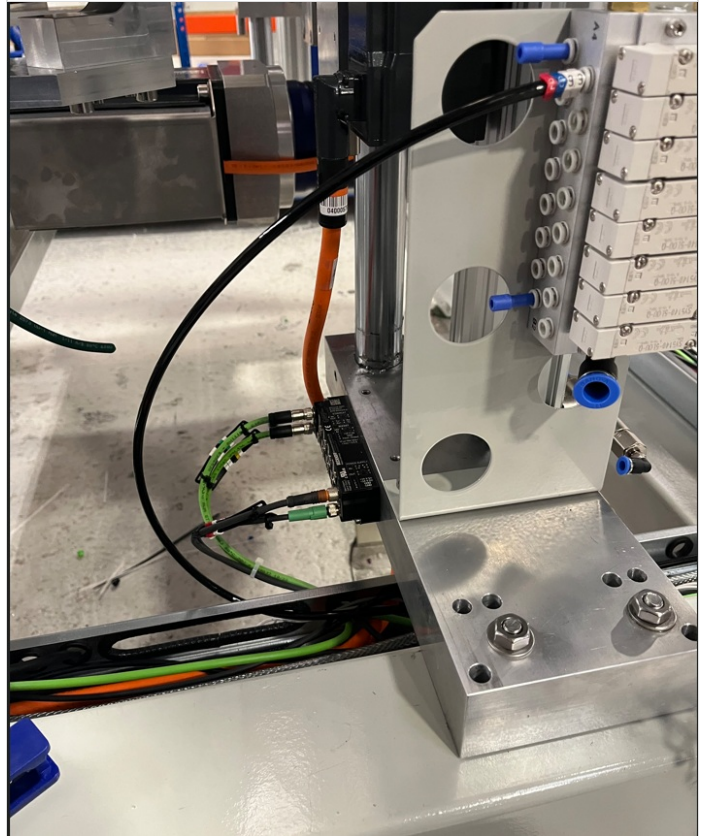

## Step 5 - Y270 Clamp hold

Pipe id 2701

Connect to port 2 on valve bank

Through trunking as shown

Connect to Nose of clamp hold cylinder

Pipe id 2709

Connect to port 4 on valve bank

Through trunking as shown

Leave 2 meter tails on both pipes exiting the trunking

Handing. Pipes always exit trunking as shown next to side clamp assembly

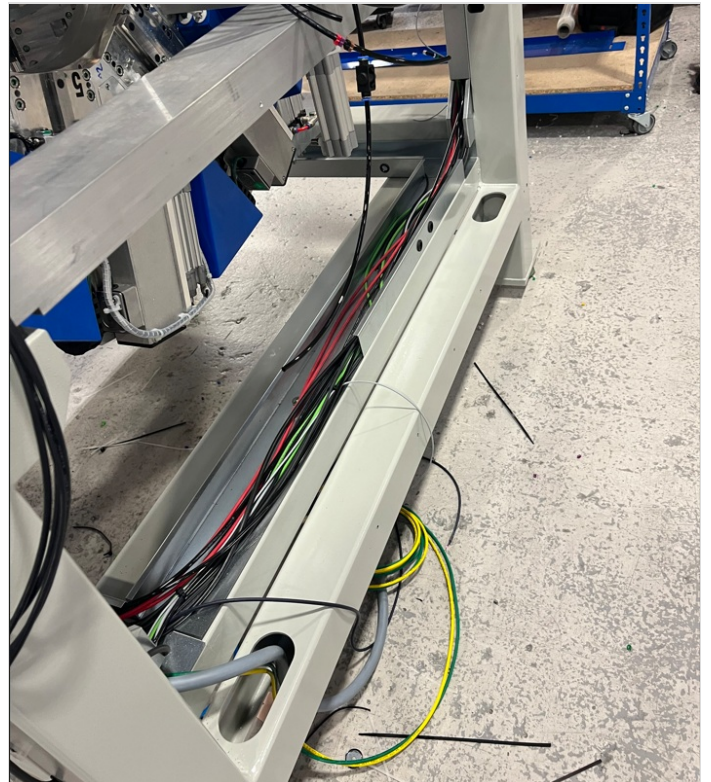
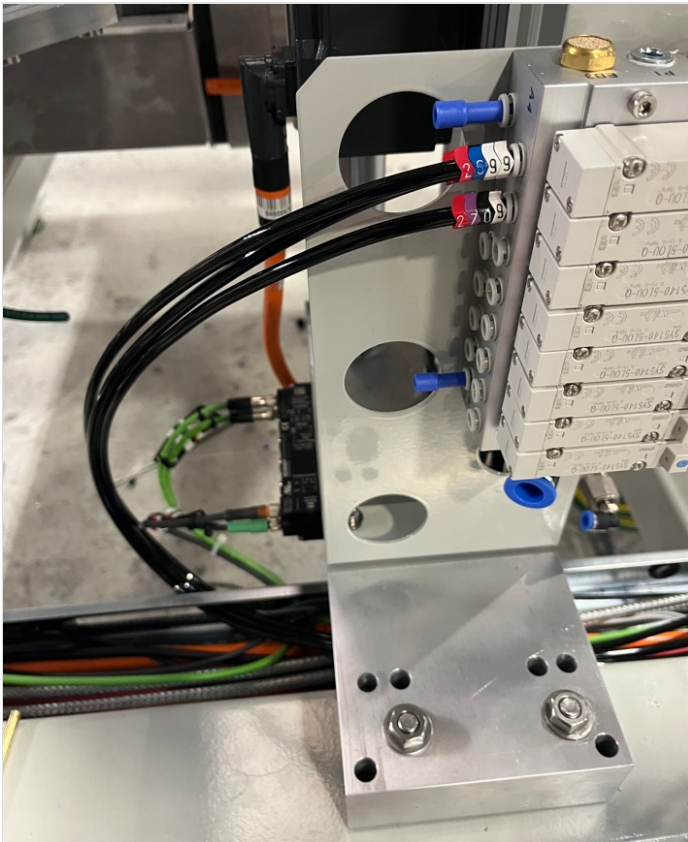

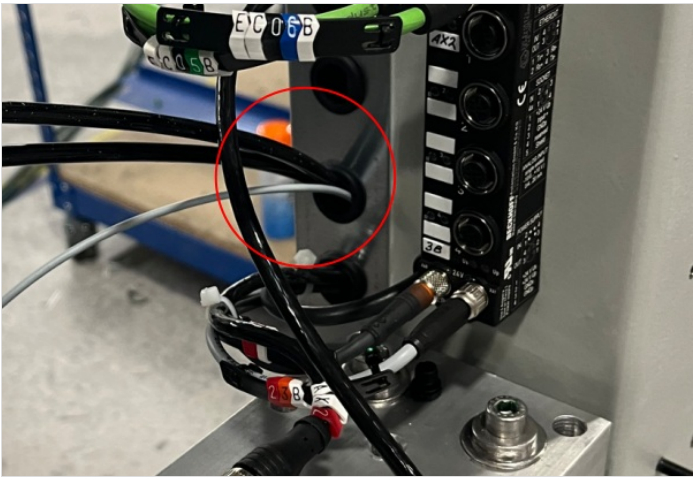
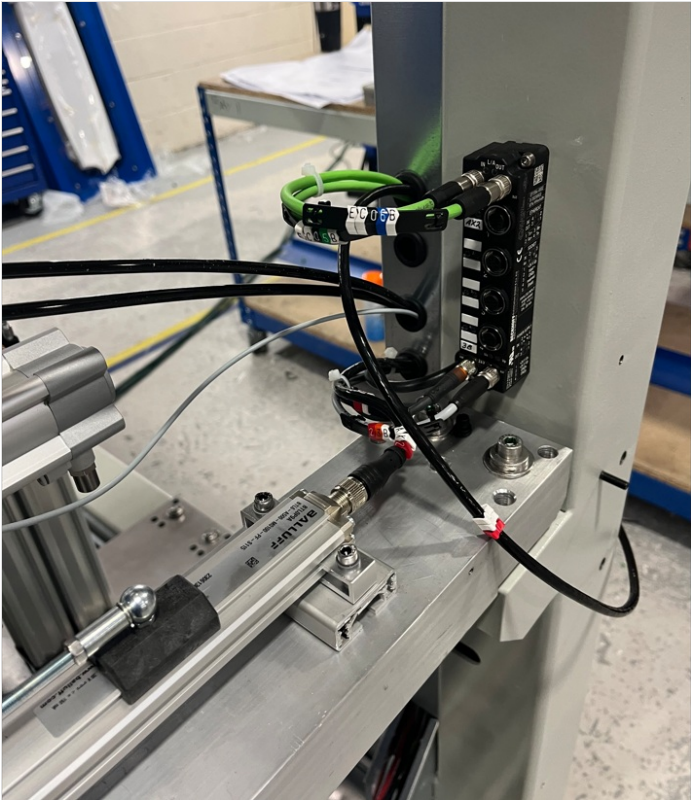

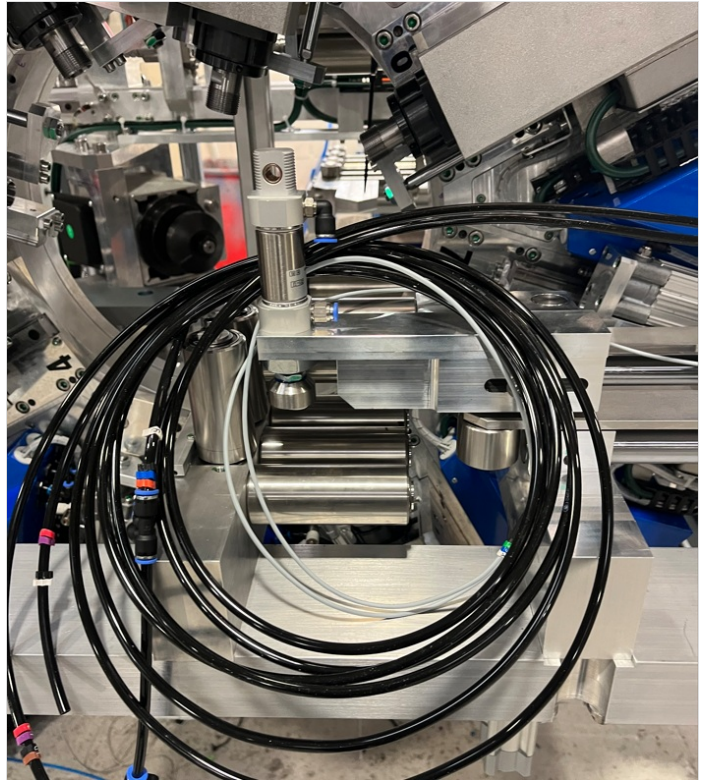

## Step 6 - Y350 Clamp infeed top

Pipe id 3501

Connect to port 2 on valvebank

Through trunking and exit at point shown

Pipe id 3509

Connect to port 4 of valvebank

Through trunking and exit at point shown

Pipe ID 3502

Run pipe between points shown

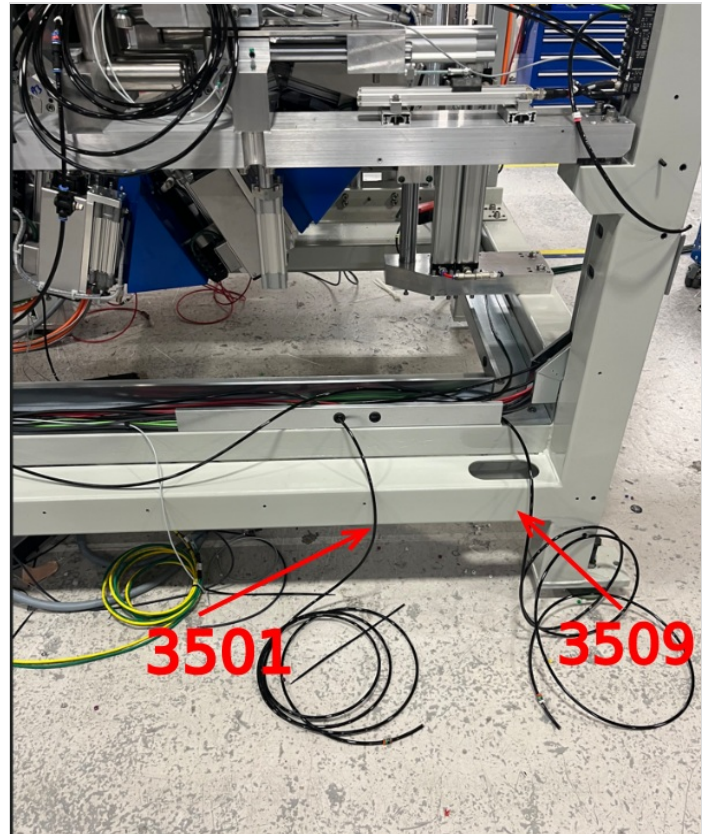
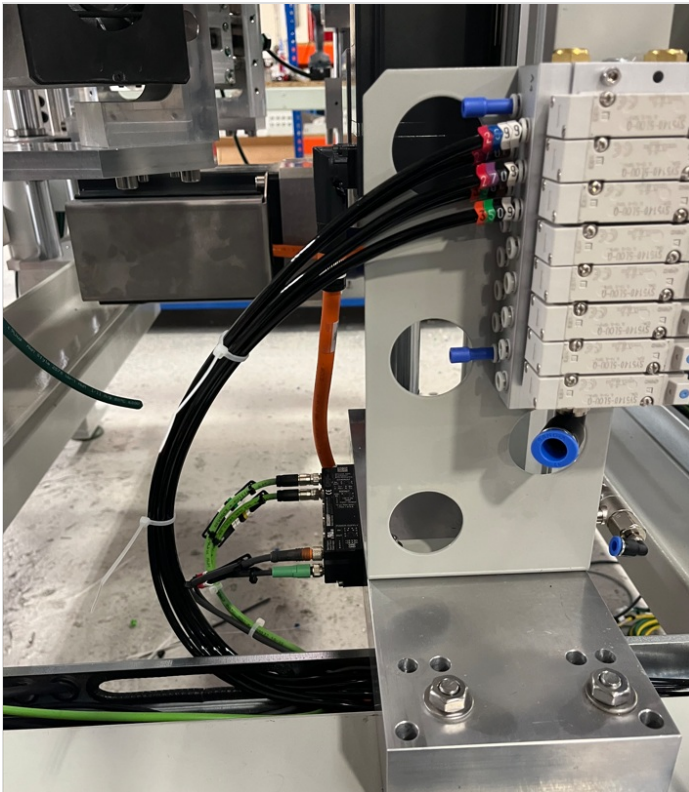



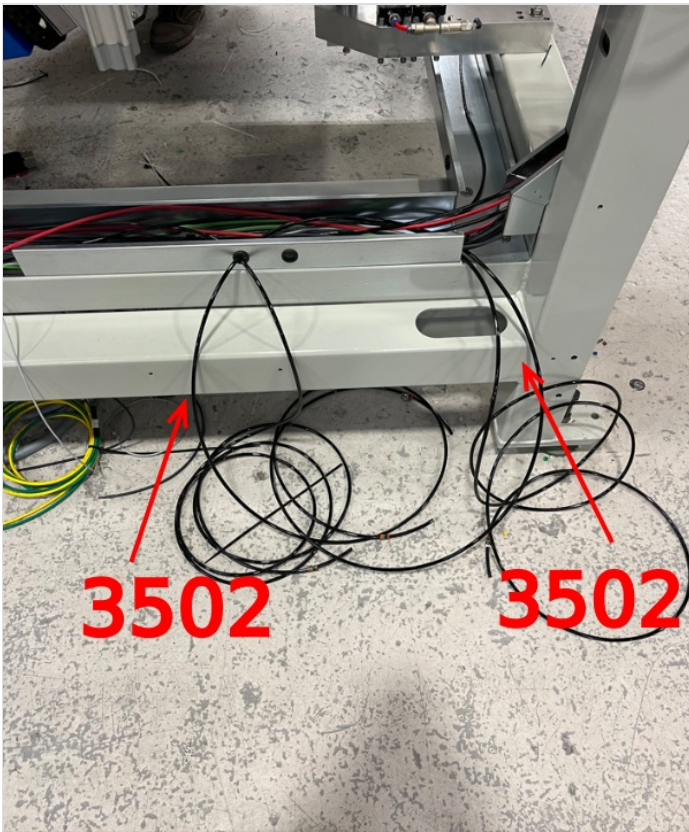

---

## Step 7 - Y351 infeed side clamp

Pipe ID 3511

Connect to port 2 on valve bank

Through trunking and exit at point shown

Pipe ID 3519

Connect to port 4 on valvebank

Through trunking and exit as shown

Pipe ID 3512

Through trunking and exit as shown

leave pipes coiled up ready for later connection

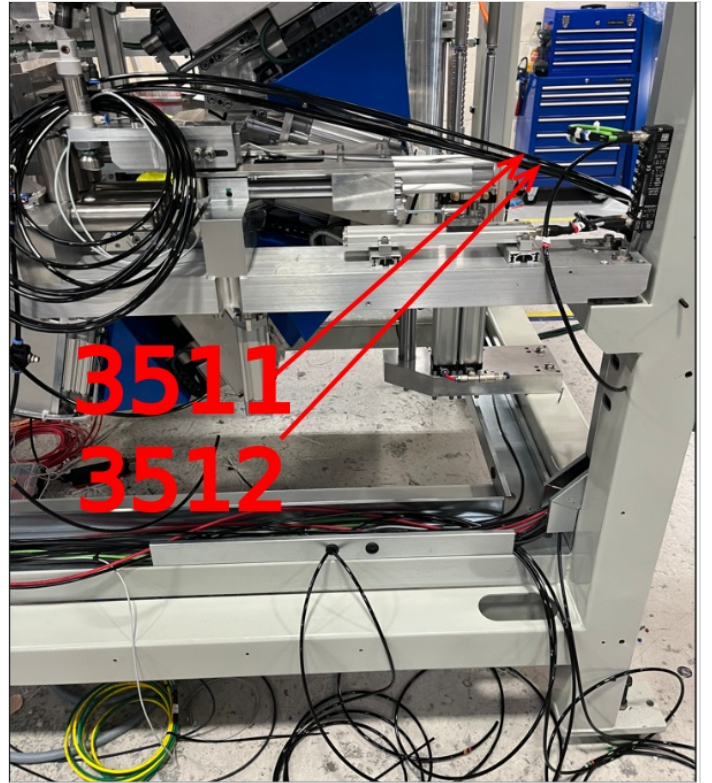
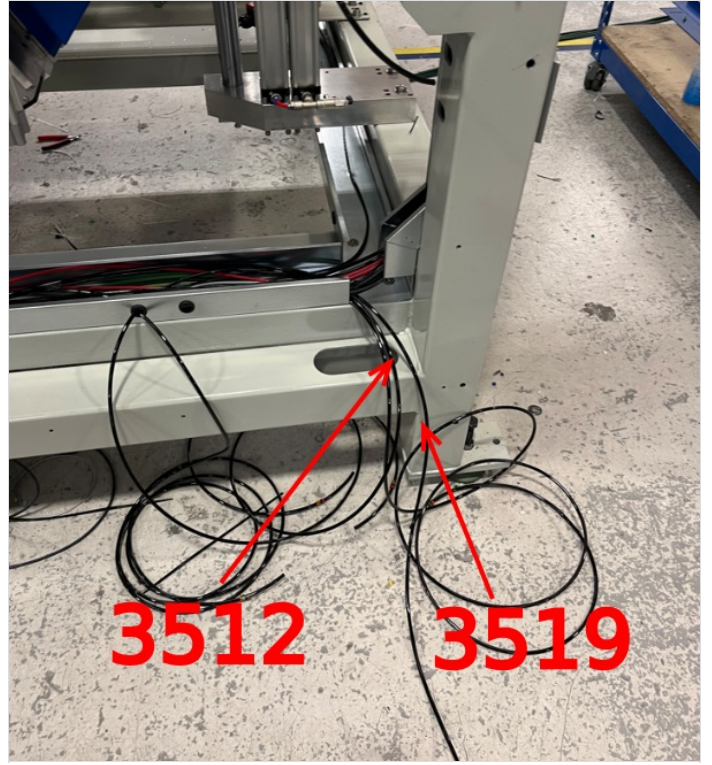

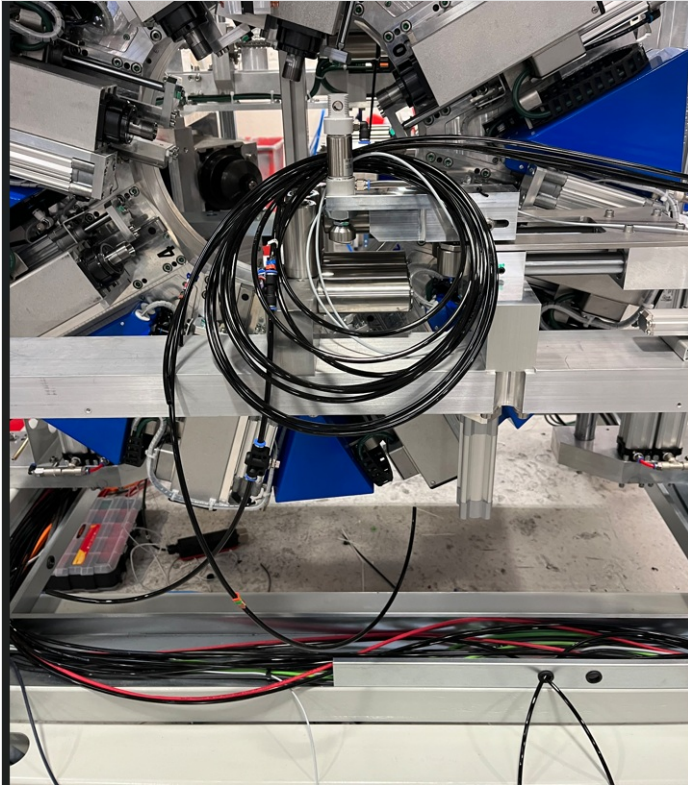

---

## Step 8 - Y360 work blowers

Pipe Id 3609

Connect to port 4 on valvebank

Blank port 2

Route through trunking and exit as shown.

Leave 1.5meters of pipe from trunking exit

Handing, pipe will always exit trunking at side shown opposite to side clamp connections

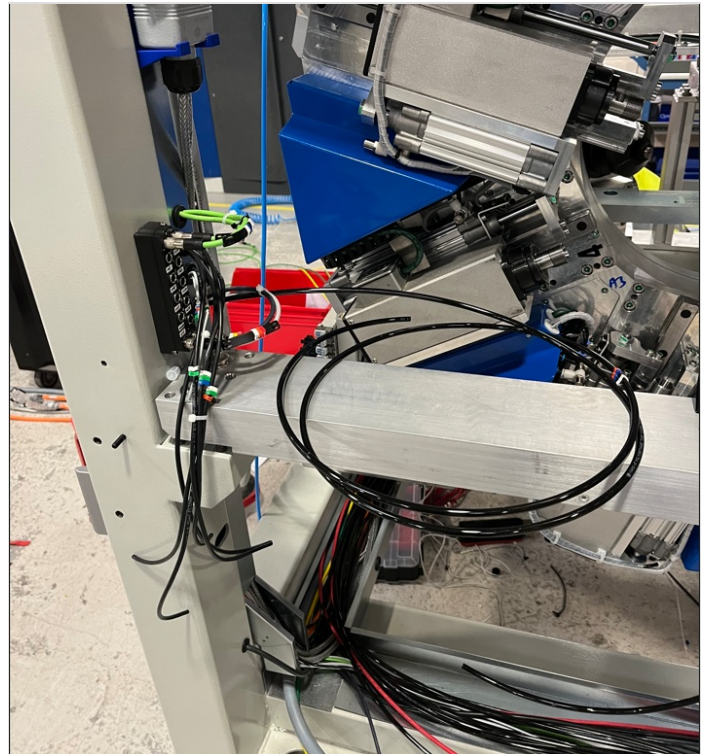
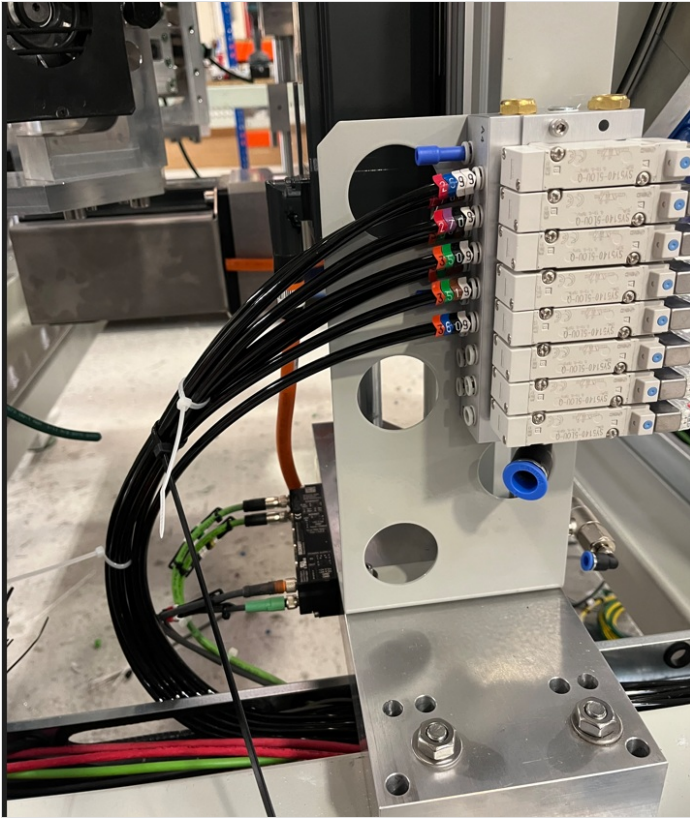

## Step 9 - Y386 Outfeed clamps

Pipe 3861

From port 2 of valvebank directly up to clamp area shown

3862 routes from clamp area to point shown out of trunking

3863 routes from clamp area to point shown out of trunking

3869 connects from port 4 on valve bank and routes to trunking exit point as shown

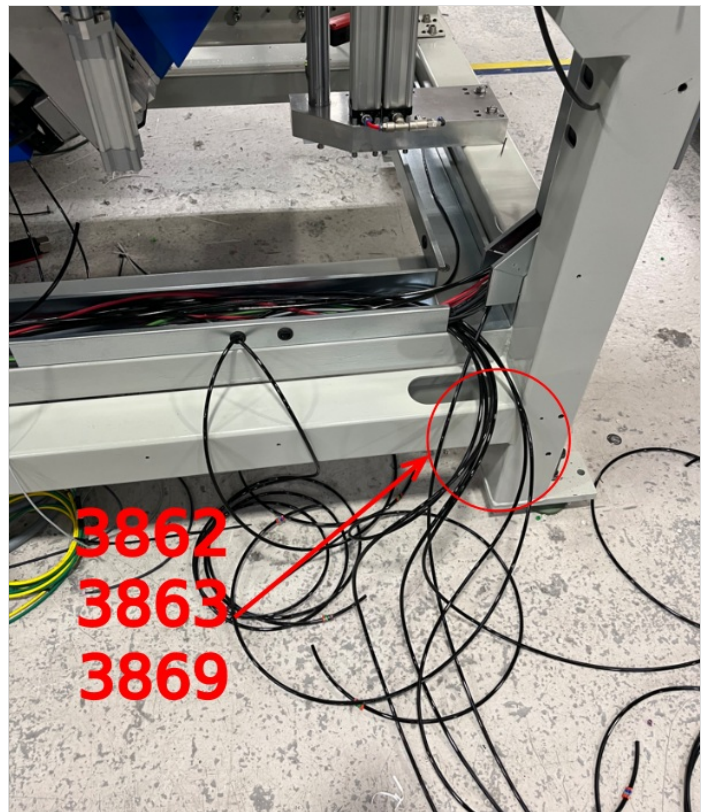
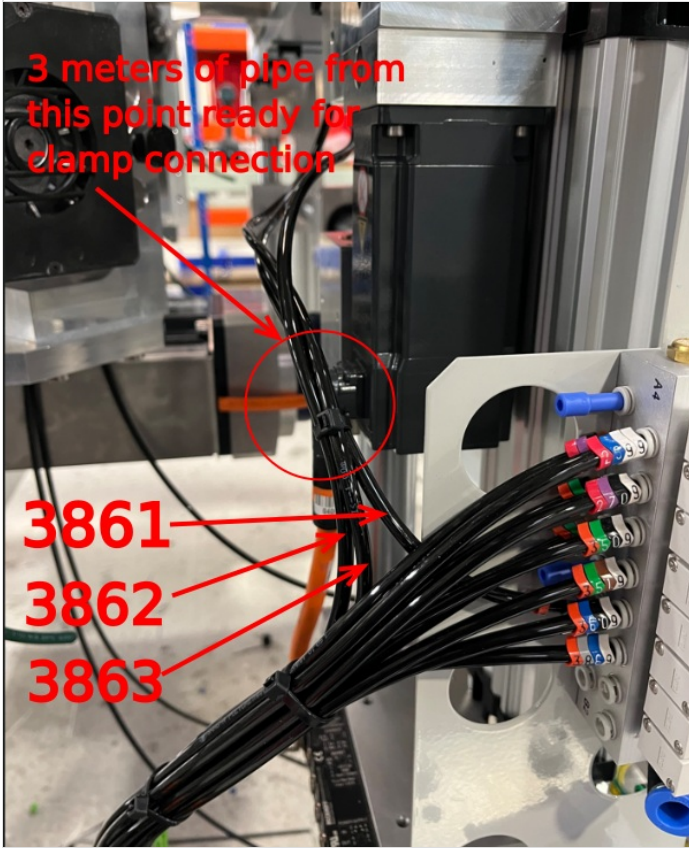

---

## Step 10 - Y389 V cut

Connect pipe 3891 to port 2 of valve bank and route as shown . Leave 1 meter tail exiting trunking

Connect pipe 3899 to port 4 of valve bank and route as shown . Leave 1 meter tail exiting trunking

Handing. Pipe exit will always be the trunking closet to the support cylinder with air adjustment fittings

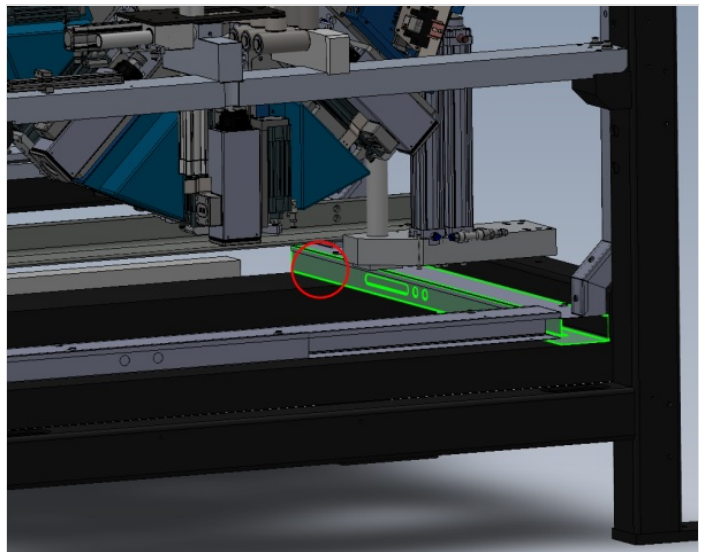

# Step 11 - Y395 Clamps V

3951

Connect to port 2 on valve bank then route through trunking and exit as shown

3959

Connect to port 4 on valve bank then route through trunking and exit as shown

3952

Route between points shown

3953

Route between points shown

Ensure 3 meters of pipe are left for connection once pipes exit trunking

Leave coiled ready for later connection

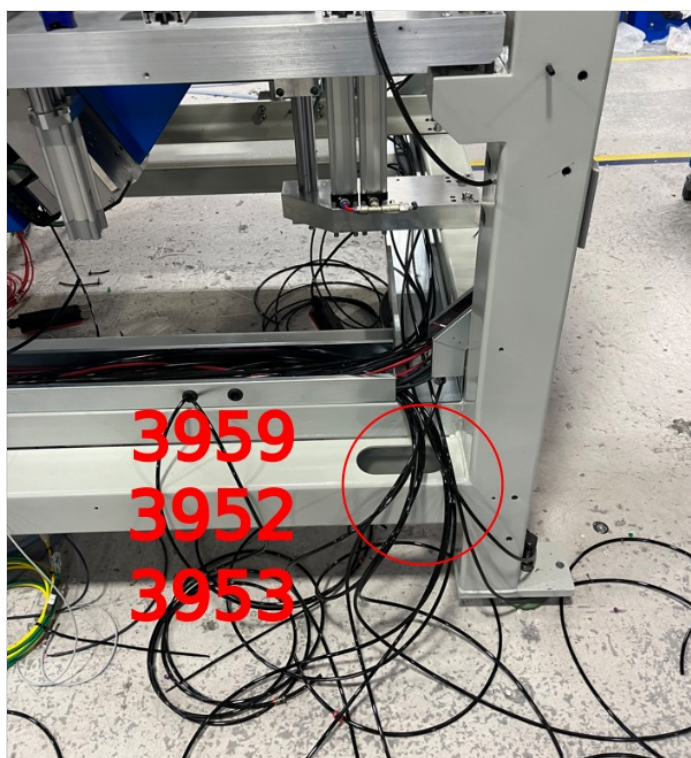
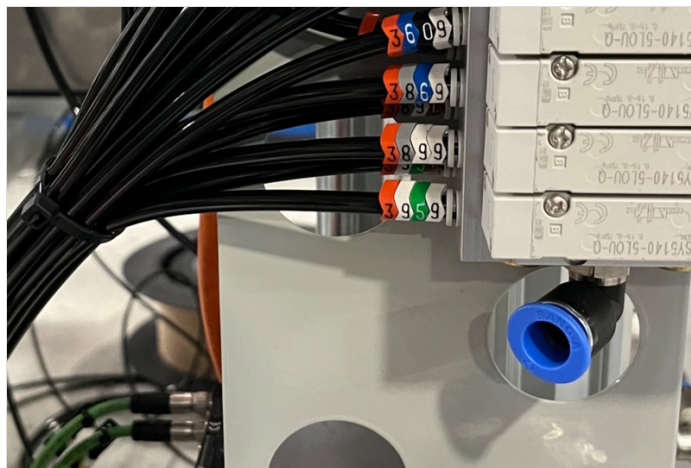
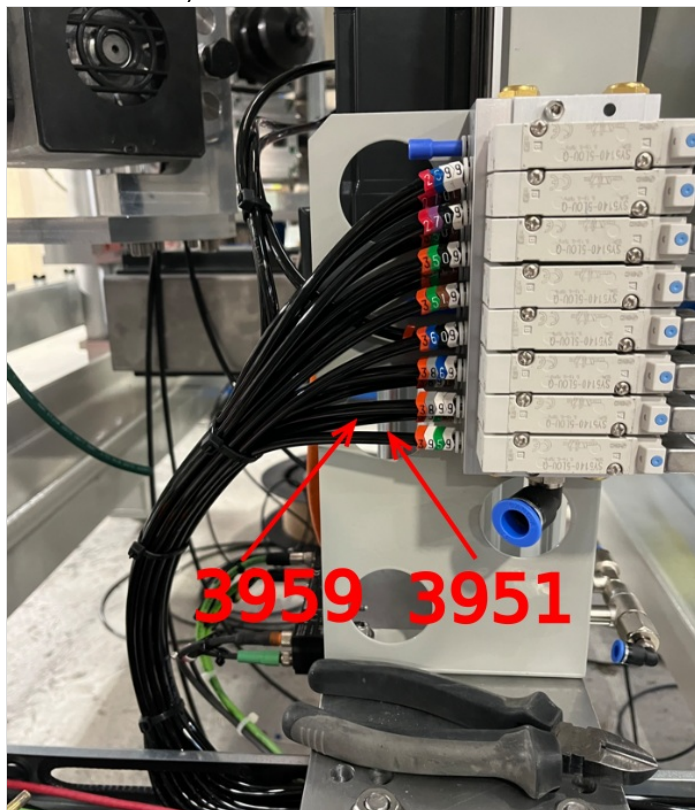





## Step 12 - 12mm blue connections Ring feed

Connection for 12mm ring main as follows

Retrieve 6mm blue pipe from point B, and route down trunking to point A

At point A, connect 6mm blue pipe to fittings as shown

Use

P0001107 12mm Y x 1

P0000161 8-6mm reducer x 1

P0001106 12-8mm reducer x 1

Route 2 off 12 mm blue pipes from fittings as shown to points C and D

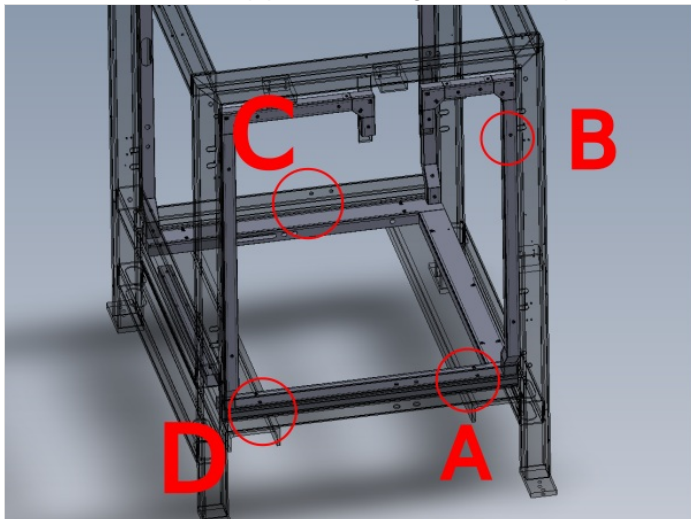

## Step 13 - 12mm blue connections Valve bank supply

Add 12mm Y fitting as shown, and connect additional 12mm pipe and exit as shown to provide valve bank air supply

Use

P0001107 12mm

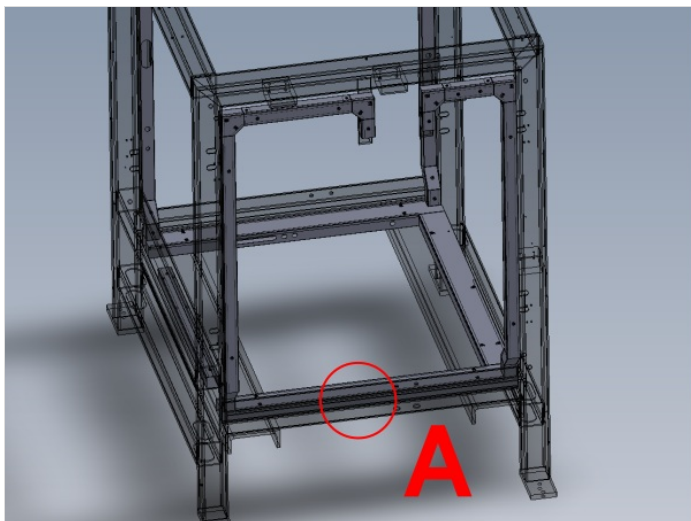

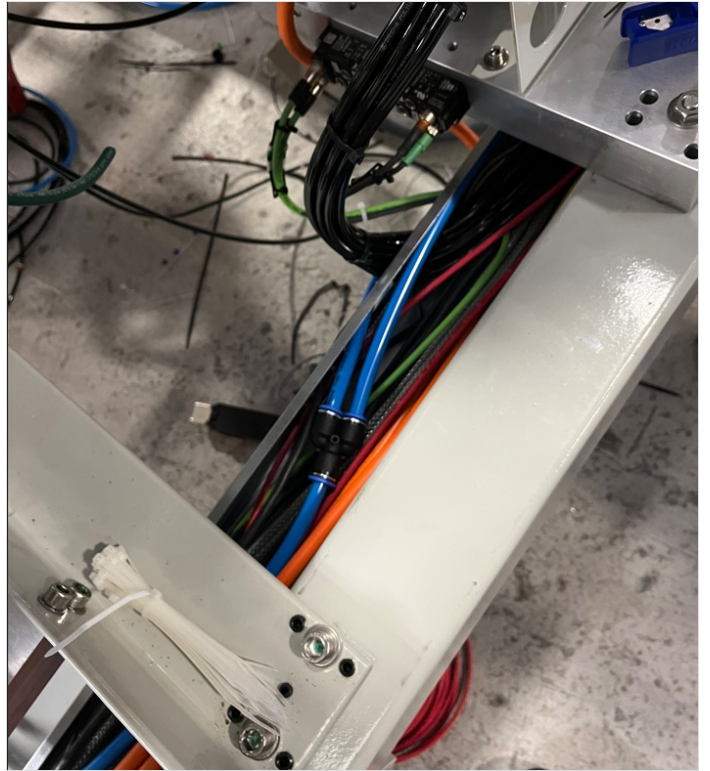

## Step 14 - 12mm blue connection V cut valve

Connect previous 12mm Y connector to new 12mm Y connector at point A or B

(please note this position will change depending on handing . Position will be determined by the location of the exit point for step 9 , Y389)

Use 12mm to 8mm reducer and connect 8mm blue air pipe , feed out of grommit along with previous fitted 2 off pipes 3891 and 3899

Use

P0001107 12mm y connector

P0001106 12-8mm reducer

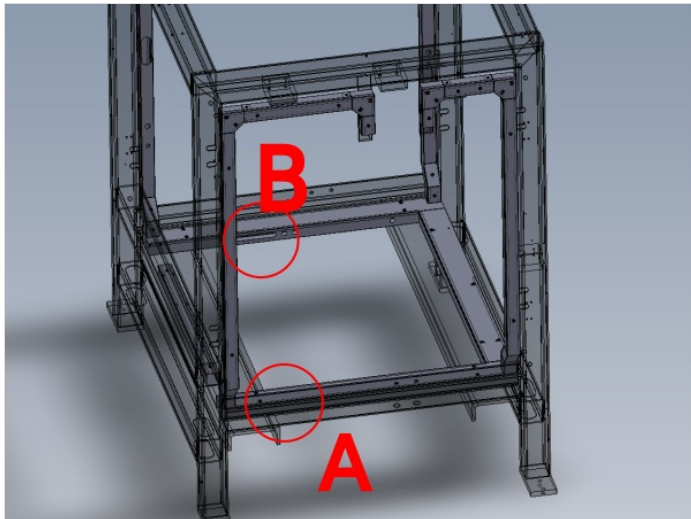

---

## Step 15 - Rear pipe exit handing

Rear pipe exits change depending on handing of machine

As viewed from rear

R-L pipes exit on the left

L-R pipes exit on the right (shown in picture)

💡 ...Pipes always exit opposite side to cables at rear of machine

Add 12mm y connector to split current 12mm blue pipe to provide supply pipe to exit rear of machine

Use

P0001107 12mm Y connector

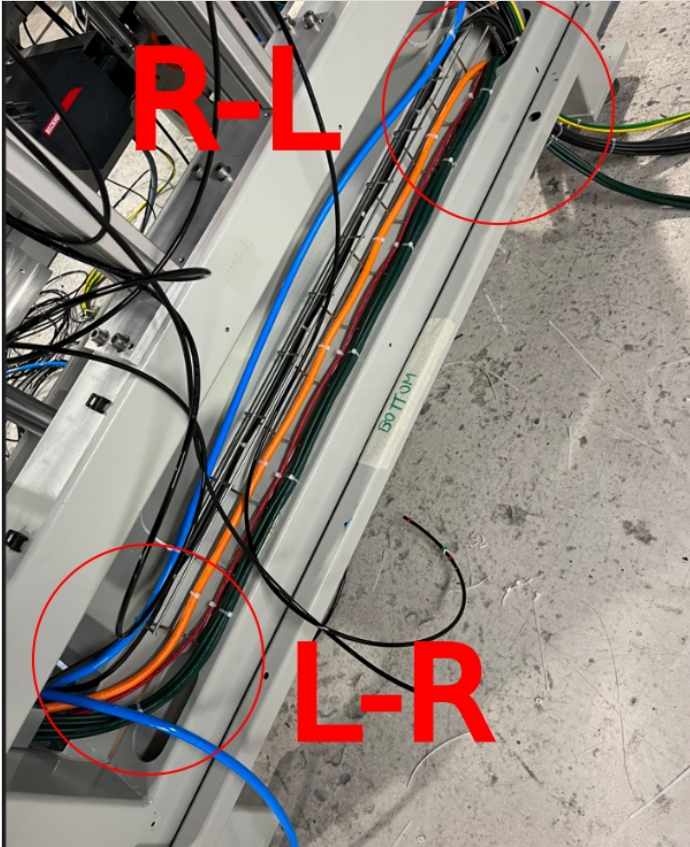

## Step 16 - Finalise Blue 12mm ring main

Bring both 12mm blue pipes to point shown and use 12mm Tee connector to join.

Run 12mm blue feed pipe to front exit of machine ( same exit as 6mm black pipes from valve bank)

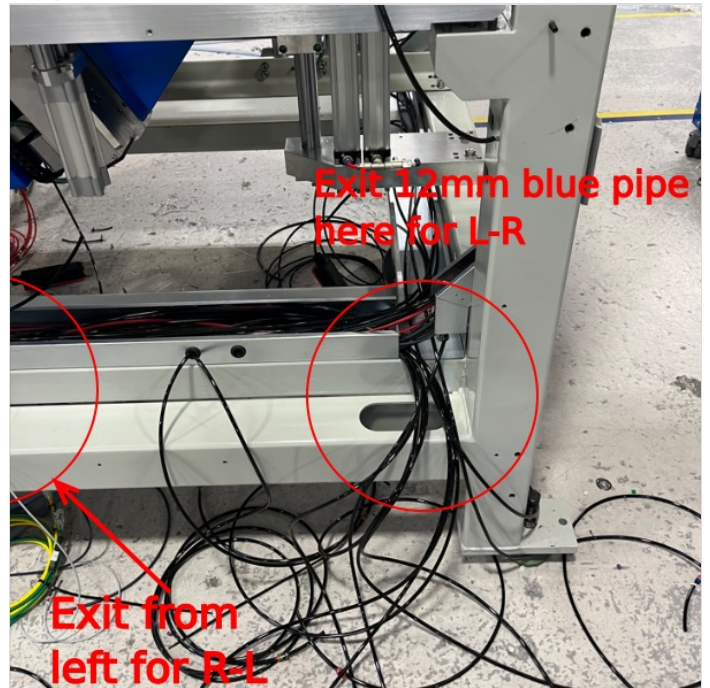
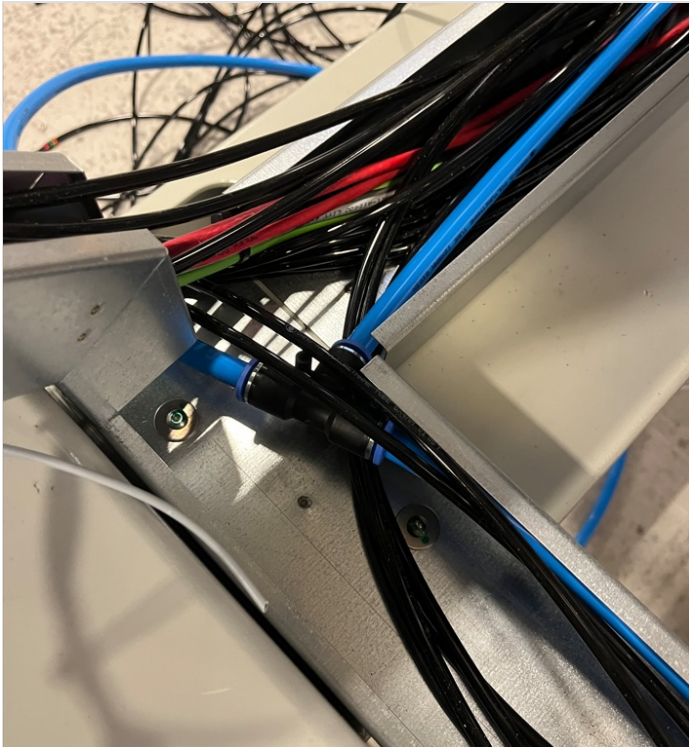

---

## Step 17 - Ring Spindle anti drop valve installation

Identify 6mm blue line from rotary head energy chain .

Add P0000513 Q valve as shown

Add P0000401 non return valve as shown

Add P0000046 as shown

Add additional 6mm blue pipe as shown and end 4 sections into energy chain

