

R0000712E Rotary Trunking

Installation of rotary energy chain and back plates

 Difficulty **Medium**

 Duration **2 hour(s)**

Contents

Introduction

Step 1 - Adhesive

Step 2 - Prepare 1st guide Section

Step 3 - Fit Energy chain mounting bracket

Step 4 - Prepare second section

Step 5 - Prepare 3rd section

Step 6 - Orientation

Step 7 - Fit D0007817

Step 8 - Fit D0003930

Step 9 - Fit D0003985

Step 10 - Fit locking screw to energy chain

Step 11 - Modify plug and mount echain bracket

Step 12 - Mount bracket

Step 13 - Finalise energy chain cables

Step 14 - Fit Access panel

Step 15 - Add air ring main

Comments

Introduction

Tools Required

Standard set Hex keys

Standard socket set

Countersink bit and drill

Copper/hide hammer

Standard hss drill set

Parts Required

D0006210 pre assembled energy chain

D0003929 Access panel

D0003930 Circular guide

D0003985 Upper circular guard

D0007817 Circular guard

D0001171 plug bracket

P0001023 6mm y adapter x 9

P0000401 non return valve

Step 1 - Adhesive

All bolts must have Loctite 243 adhesive applied unless otherwise stated.

All bolts must be marked with pen once completed to indicate adhesive and correct tension has been applied



Step 2 - Prepare 1st guide Section

D0003985 needs preparing before fitting

1 All back plates for the rotary trunking need to be checked for correct countersink depth. Any protrusion from main face will cause energy chain failure

Check and if proud, use a countersink to increase depth



Step 3 - Fit Energy chain mounting bracket

Mounting bracket D0006240 needs fitting to D0003985

1 Measure position of bracket onto circular guard (291mm)

2 Use a pointed m5 grub screw screwed into bracket hole indicated, hold in position on guard, and use hide hammer to transfer position mark

3 Drill to 6mm and fix bracket with m5x 16 cap head and large m5 washer

4 Drill 6mm through indicated hole

5 Fix with M5 x 16 countersink, large m5 washer and nyloc nut

6 This countersink bolt head must be flush to block. If proud, use a countersink bit to increase depth

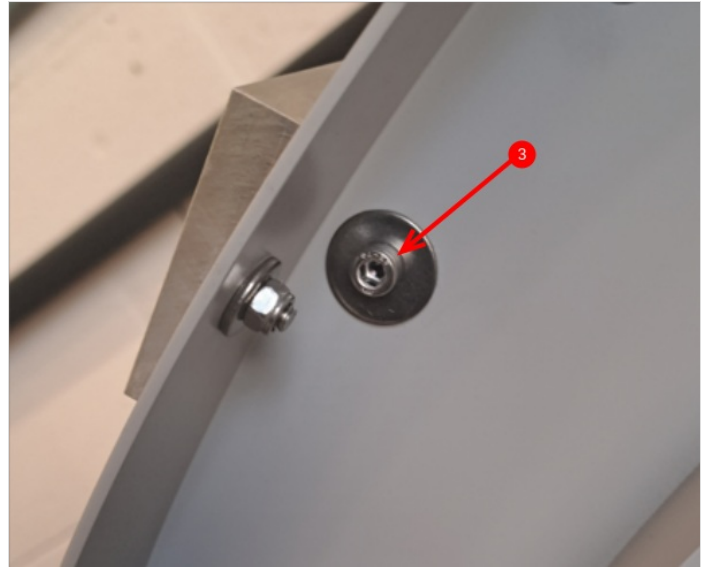
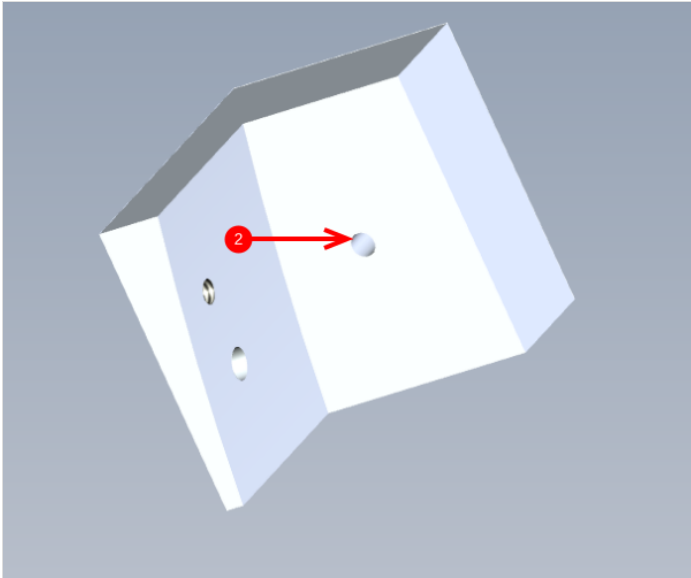
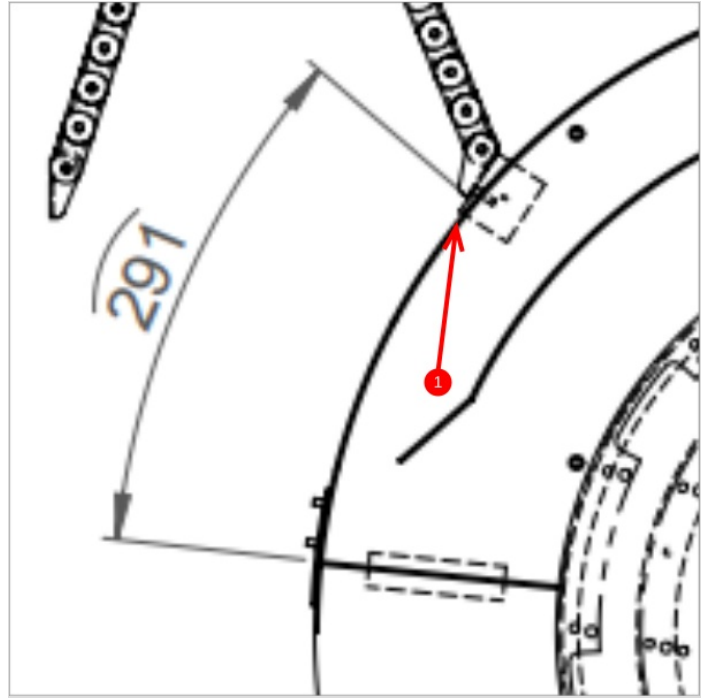
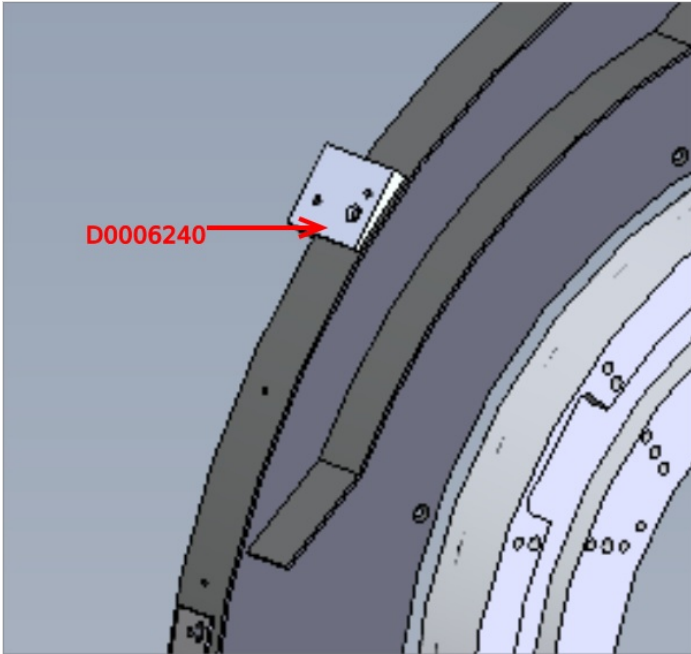

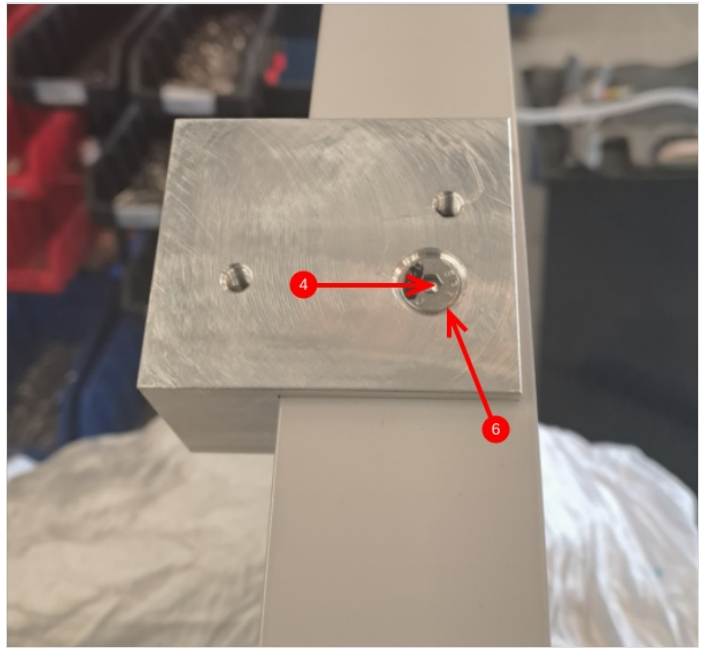

Step 4 - Prepare second section

Check countersink holes in D0003930 are to the correct depth.
Rework with countersink if fasteners sit proud.

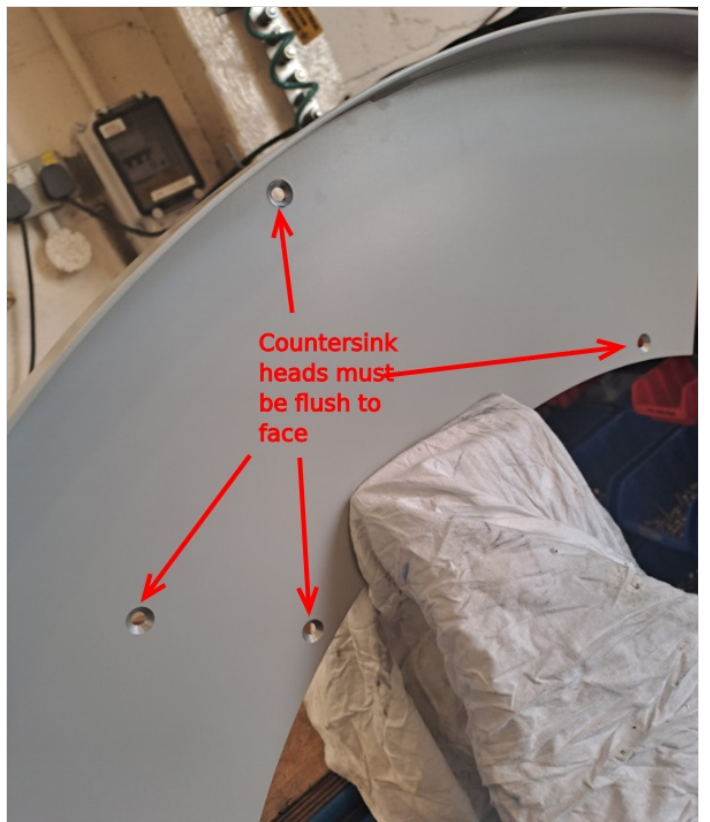

Step 5 - Prepare 3rd section

Check countersink holes in D0007817 are to the correct depth.
Rework with countersink if fasteners sit proud.



Step 6 - Orientation

It is vital to achieve correct orientation of above parts

Use M8 holes indicated as reference point for fitting

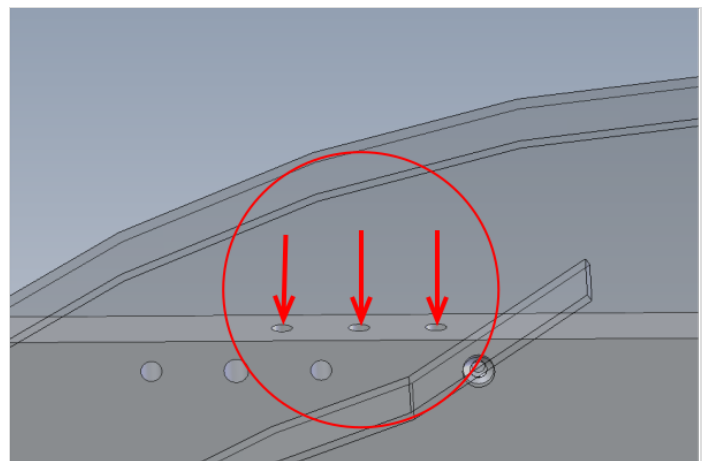
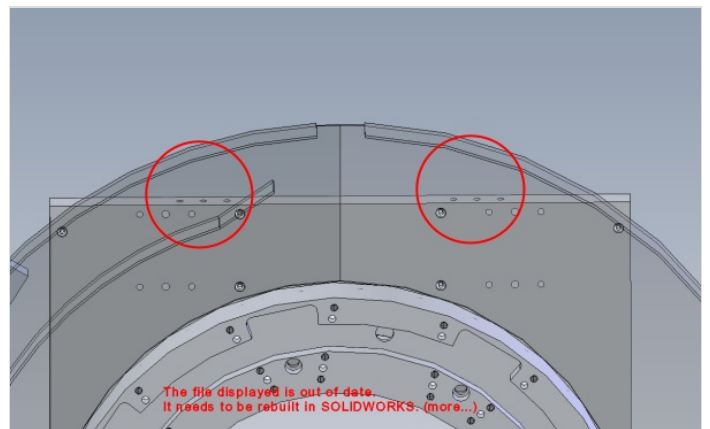
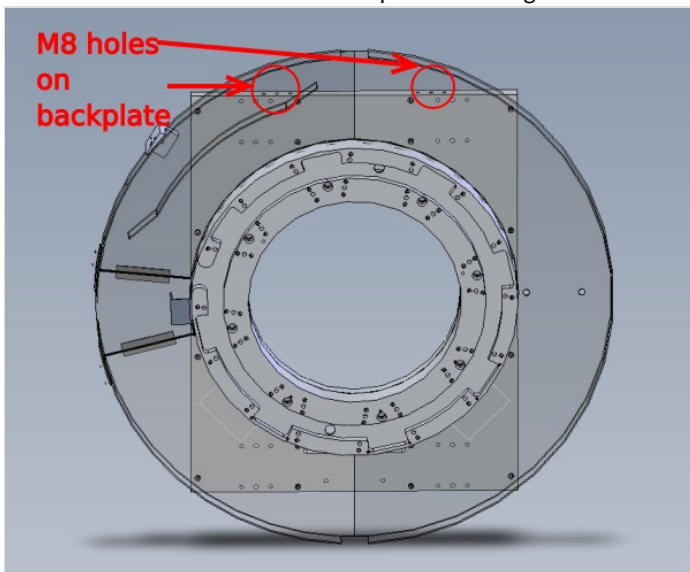

Step 7 - Fit D0007817

Mount D0007817 to main rotary base and fix with m5 x 10 countersink bolts

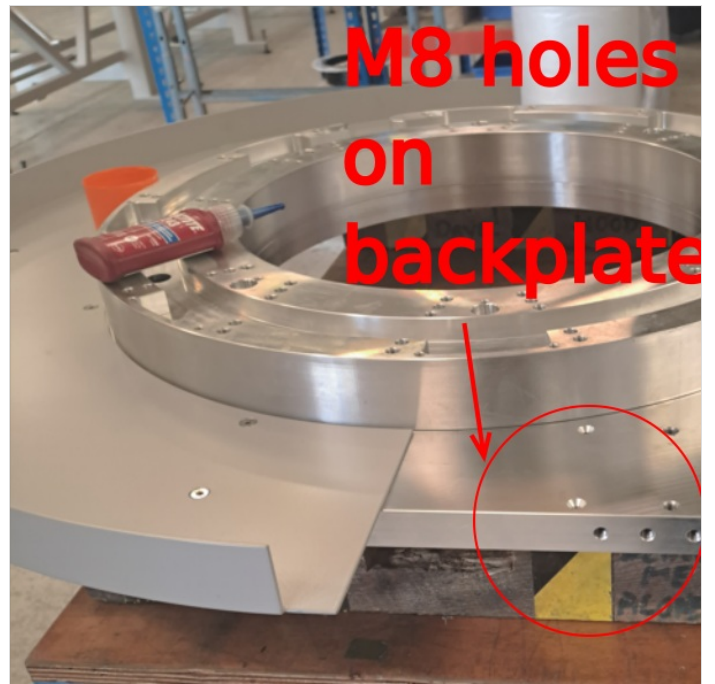

Step 8 - Fit D0003930

Mount D0003930 to main rotary base and fix with m5 x 10 countersink bolts

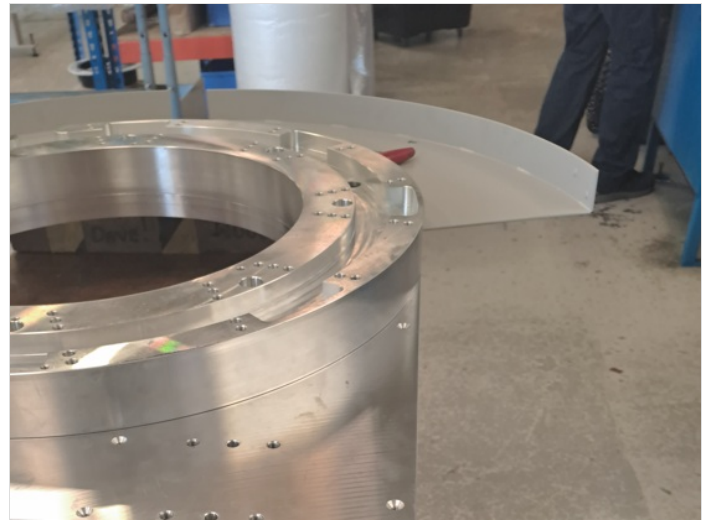

Step 9 - Fit D0003985

Mount D0003985 to main rotary base and fix with m5 x 10 countersink bolts

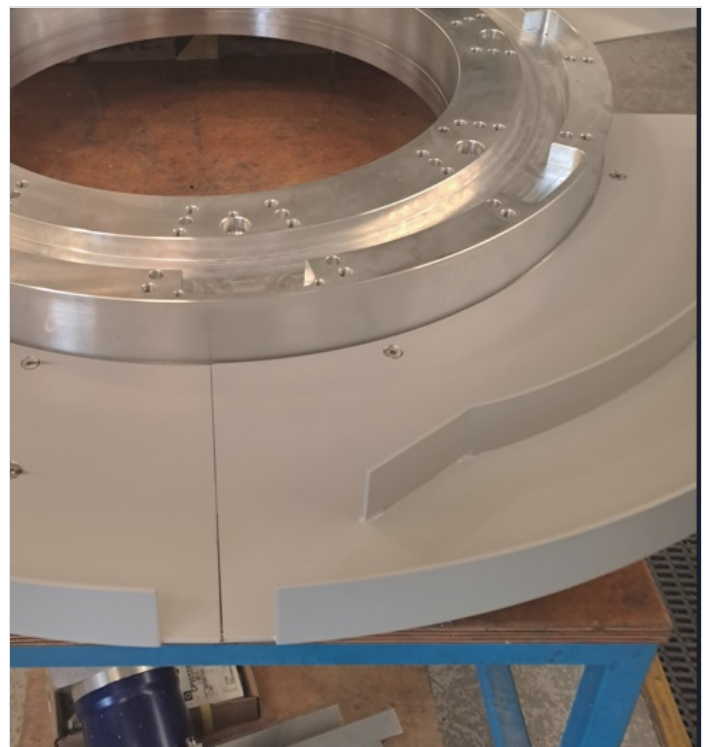

Step 10 - Fit locking screw to energy chain

Drill and tap m3 to plugged end ONLY of energy chain assembly
Use m3 x 6 pan head bolt to secure

⚠ ...Caution damage to cables is possible Use a shield over cables to protect

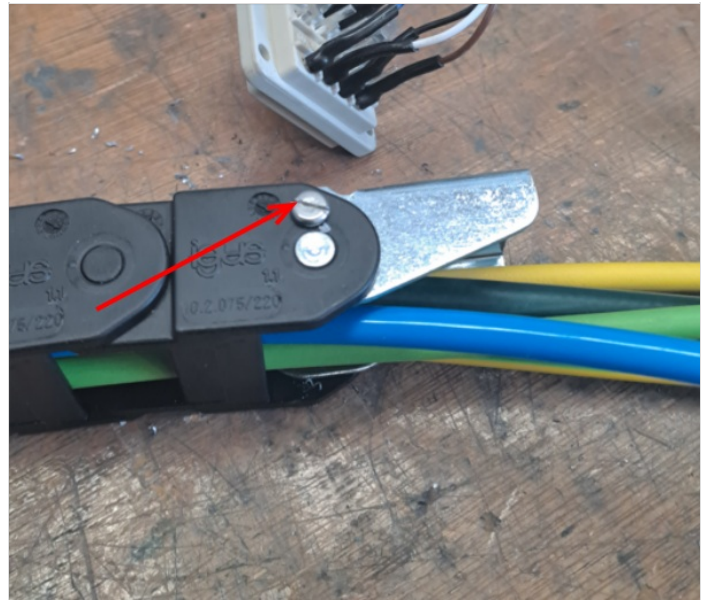

Step 11 - Modify plug and mount echain bracket

1 Modify plug to allow cable and pipe clearance as shown

2 Modification is required to give access as indicated

3 Attach chain bracket plug on end of cables at this end, with 2 off m5 x 10 button head and washers

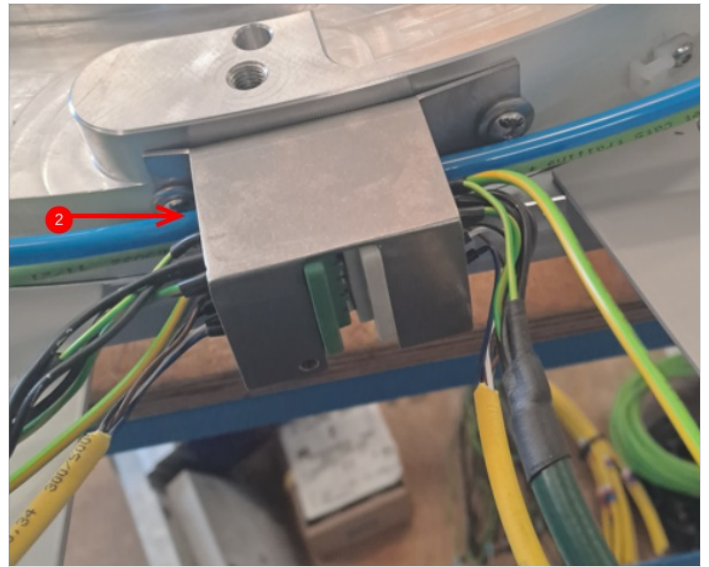
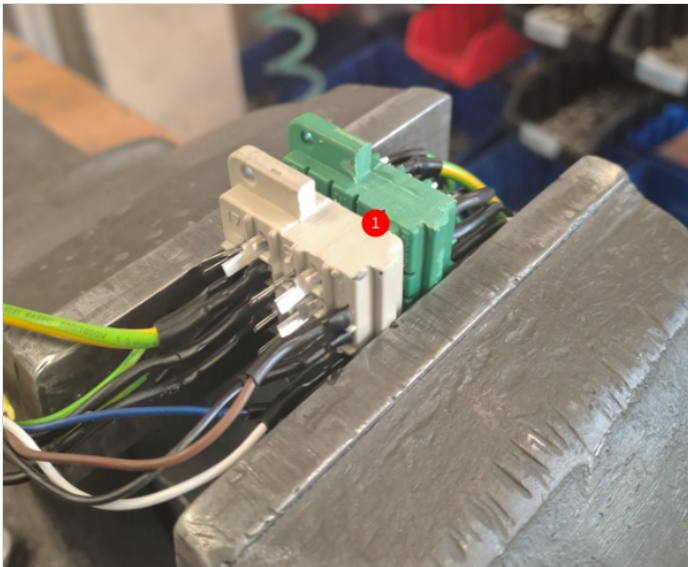

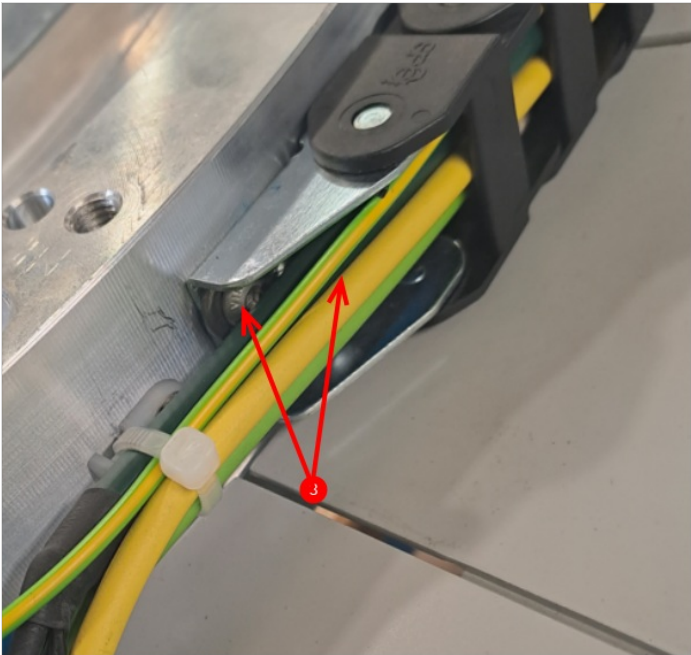

Step 12 - Mount bracket

1 Mount bracket D0001171 using 2 off m5 x 10 button heads and heavy washers

2 Captivate plug with m4 x 12 socket cap

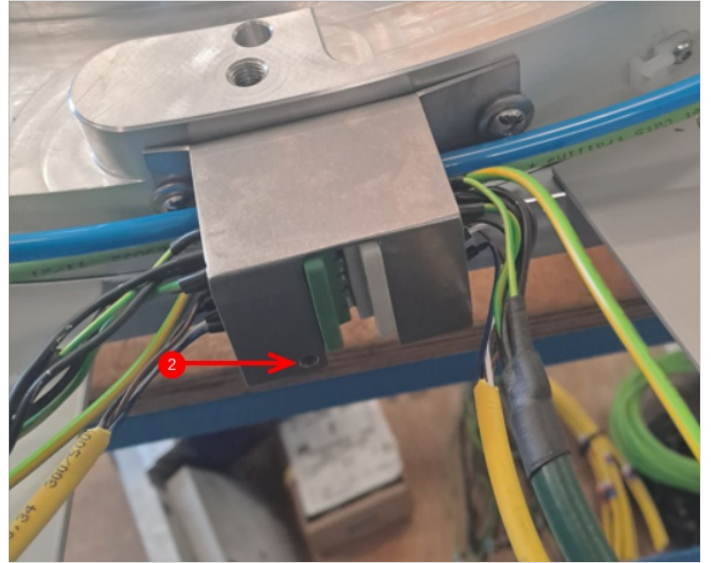
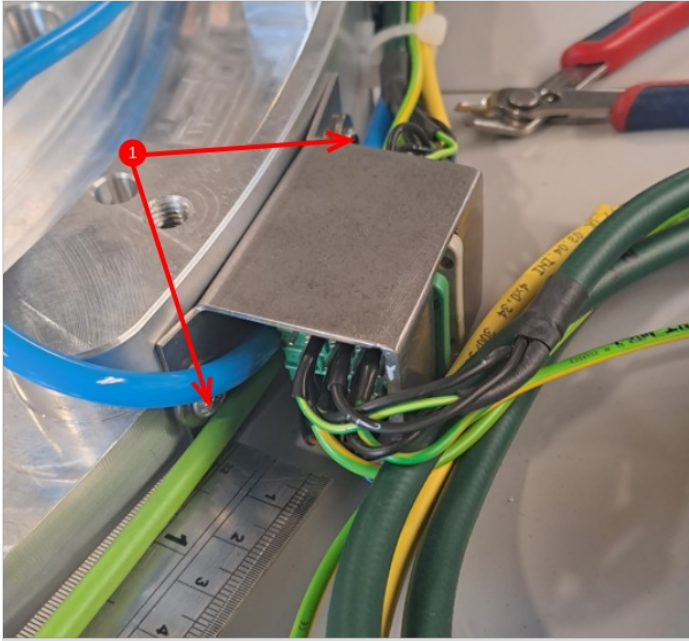

Step 13 - Finalise energy chain cables

1 ensure 600mm of green ethernet cable is set

2 ensure 6mm blue pipe is set to position

3 Ensure cable restraint is used once cable and pipe length are set (M4 may need drilling)

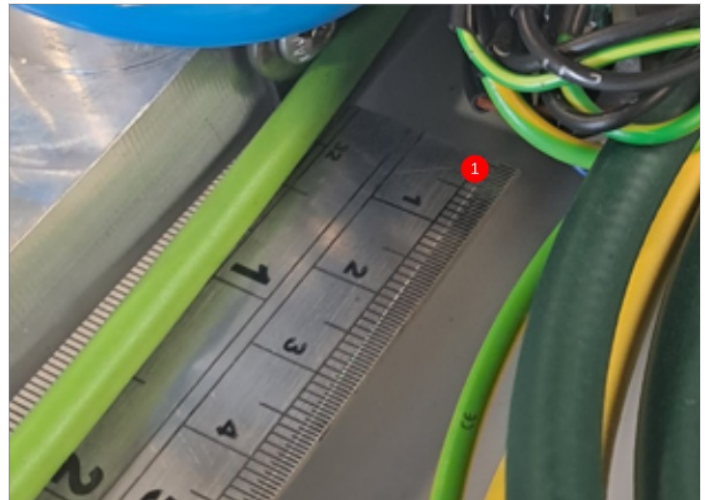

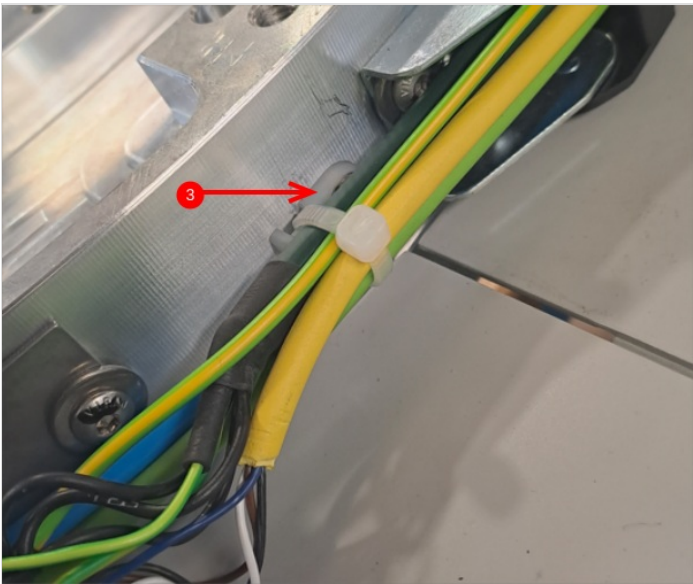

Step 14 - Fit Access panel

- 1 slide access panel into position
- 2 Fix energy chain to panel with m5 x 16 button heads, washers and nyloc nuts

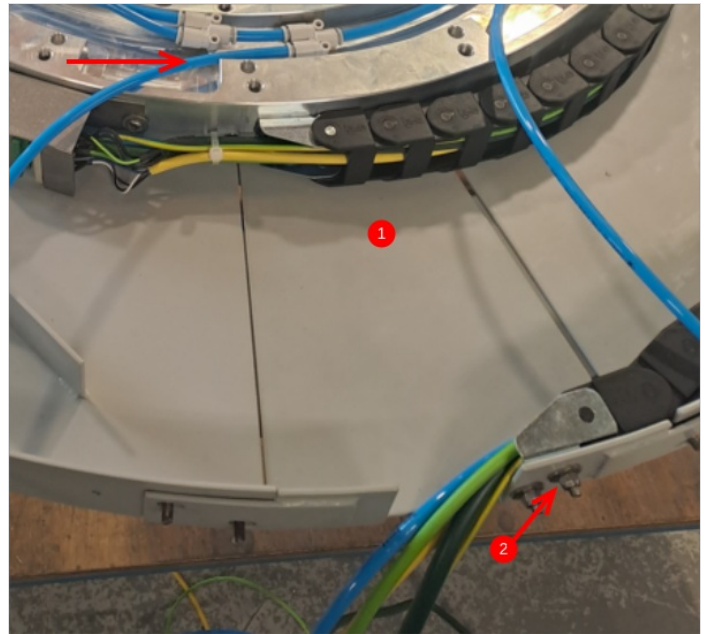

Step 15 - Add air ring main

- 1 Connect ring main as shown. Ensure fittings P0001023 are placed in the same locations as shown in picture
- 2 Cap off 8 off ends of air pipe as shown
- 3 Add P0000401 to end of trailing 6mm blue pipe. Note orientation of non return valve
- 4 Purge system with air to perform pneumatic leak test. Once purged, system should hold pressure for minimum 1 hour

