

# R0000570B Bench Assemble 1st stage Ejector

Bench assembly details for ejector components

 Difficulty **Medium**

 Duration **0.5 hour(s)**

## Contents

Introduction

Step 1 - Unless otherwise stated

Step 2 - Assemble slider blocks

Step 3 - Assemble Rod end plate

Step 4 - Extension blocks

Comments

## Introduction

### Tools Required

Standard hex key set

### Parts Required

B0000033 Linear Bearing: Ø20 x 30 Compact (Metal Case Only) x 6

D0004015 Front Slider (5301) x 1

D0004016 Rear Slider x 1

D0004329 Rod End Plate (5304) x 1

D0004420 Extension Linear Block x 2

H0004630 Shaft 20mm: 345 Ejector Crossx 1

## Step 1 - Unless otherwise stated

All bolts to have Loctite 243 adhesive applied unless otherwise stated

All Threaded Pneumatic connections to have Loctite 570 applied

All bolts to be pen marked once adhesive applied and correct tension added



## Step 2 - Assemble slider blocks

D0004015 Front Slider

D0004016 Rear Slider

1 Add M6 x 6 grubscrews to indicated holes, 4 off in total. Use Loctite 572 to seal grubscrews to blocks. Ensure grubscrews sit flush with face of block when fitted. Tap hole deeper with M6 tap to allow grubscrew to sit further in if not possible to achieve flush fitment.



...Always use an airline to remove internal swarf from blocks if tapping is required

2 Fit 4 off B0000033 Linear Bearing as shown. Ensure yellow face of bearing is fitted on the indicated faces. Ensure when fitted that no ball chamber is visible on bearings

3 Fit 4 off M6 straight grease nipples to indicated points (2 per slider) Use loctite 572 to seal

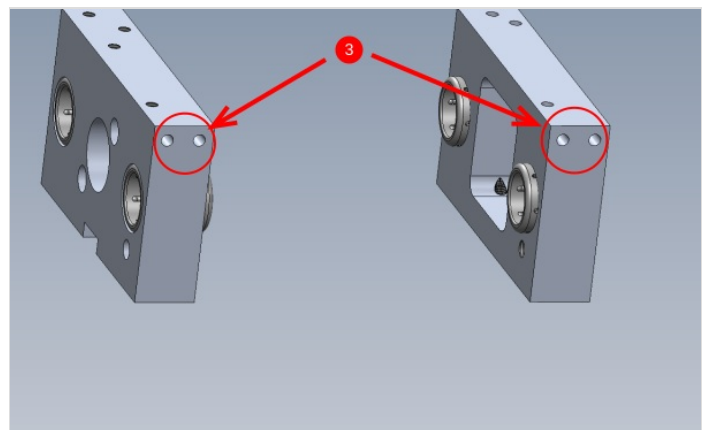
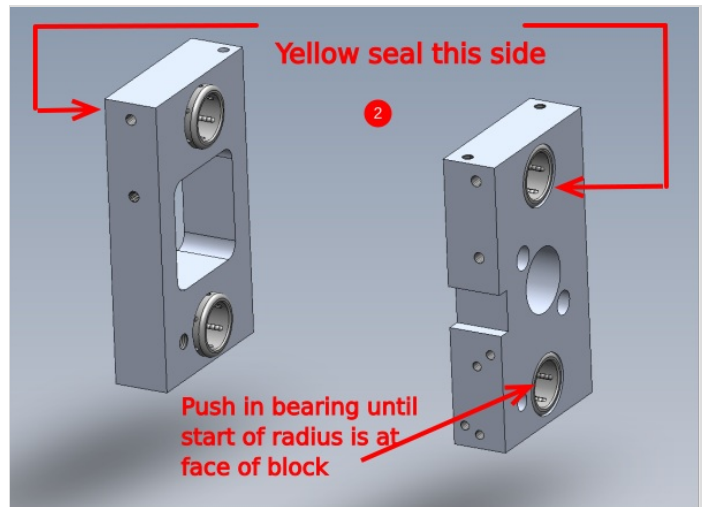
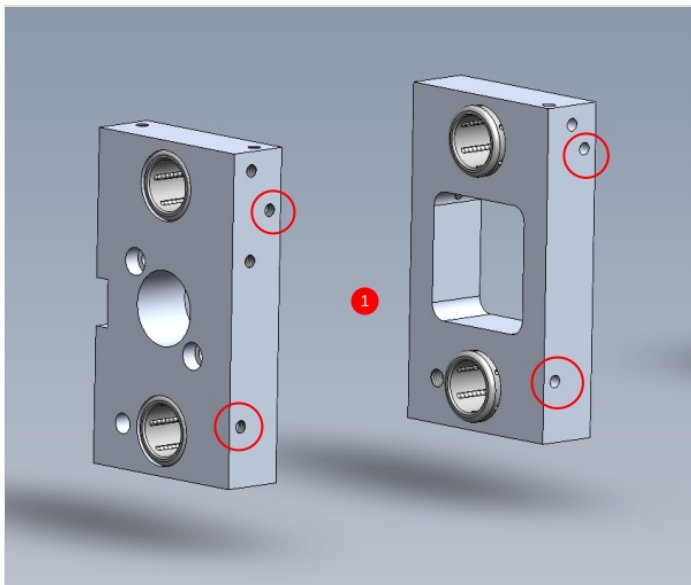

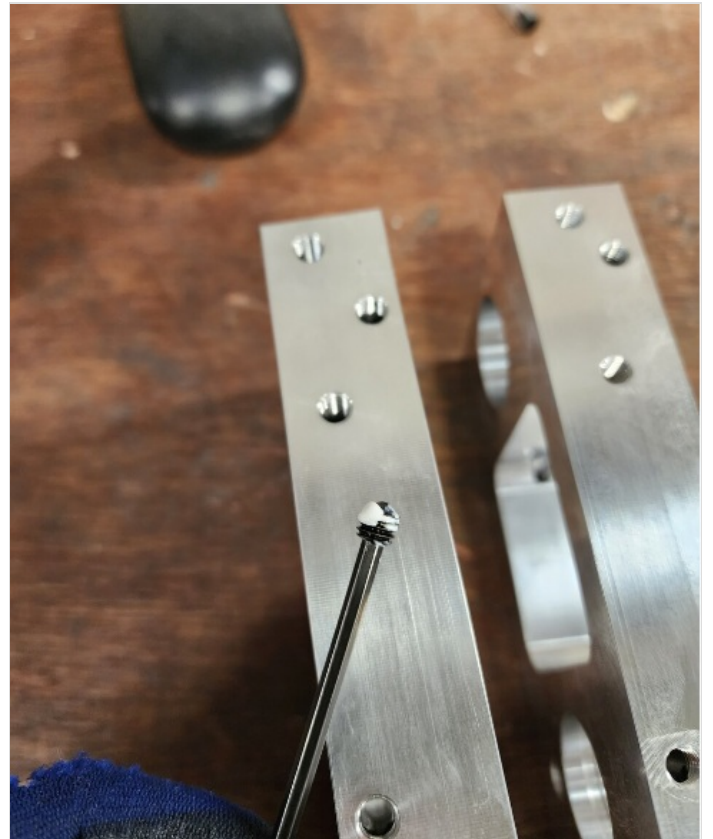

---

### Step 3 - Assemble Rod end plate

Insert H0004630 Shaft 20mm: 345 Ejector Cross x 1 into D0004329 Rod End Plate (5304) as shown

Dimple in shaft is offset, when correctly fitted, shaft is equally protruding either end of block

Secure with M8 x 20 kcp grubscrew, ensuring dimple is entered by the grubscrew

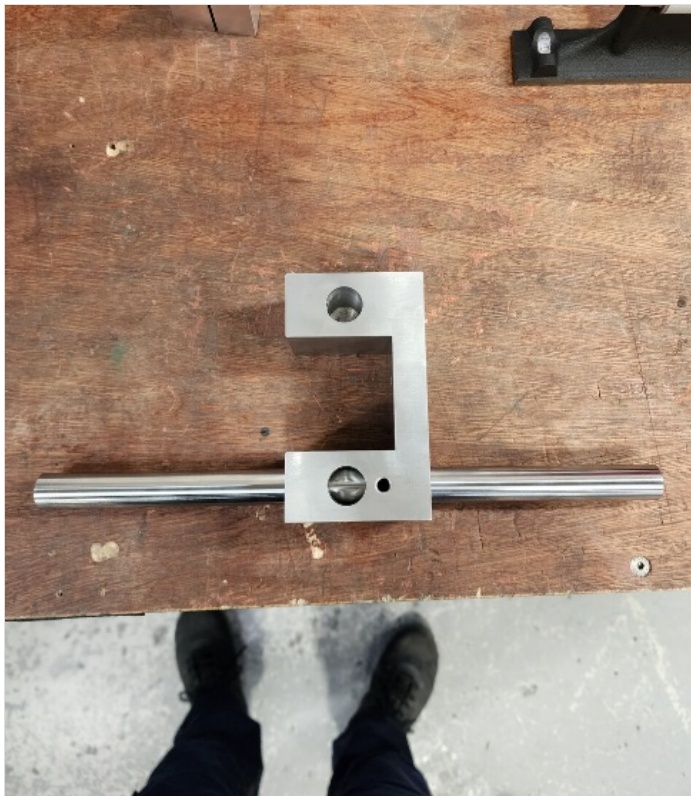
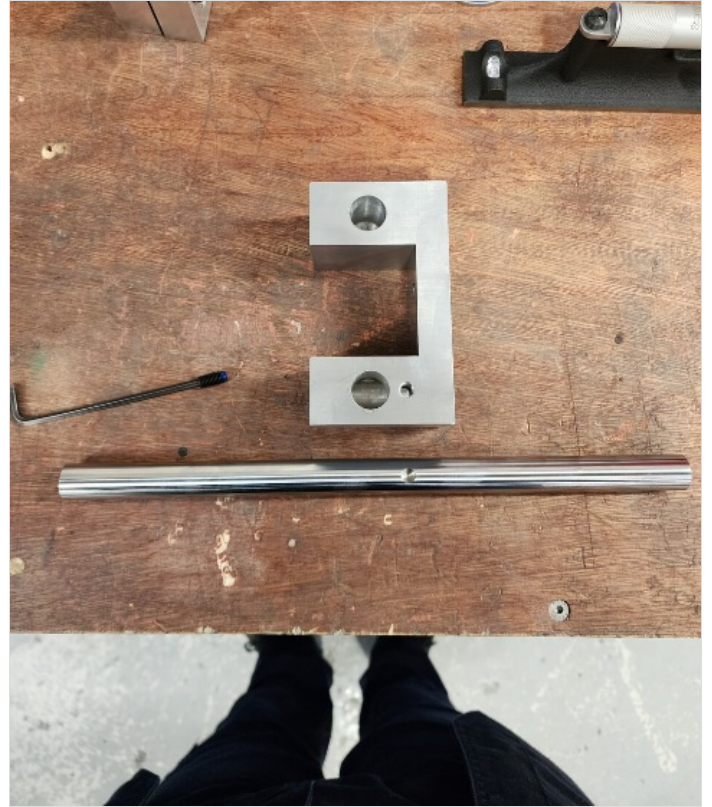
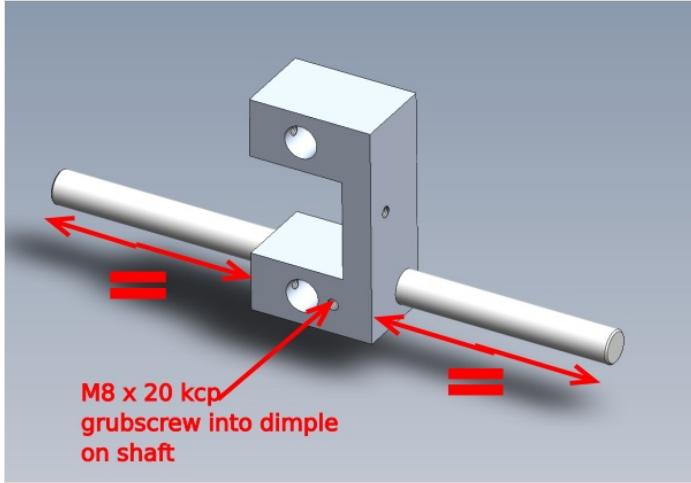

## Step 4 - Extension blocks

Degrease blocks before fitting bearings

Fit 2 of B0000033 Linear Bearing to 2 off D0004420 Extension Linear Block

Ensure yellow seals are facing the shown direction

Apply liberal grease to these bearings

