

# Flowline Turret Upgrade - Somatec

Flowline Turret Upgrade

 Difficulty Easy

 Duration 120 minute(s)

## Contents

Step 1 - Remove existing turret and associated parts

Step 2 - Fit Somatec mount

Step 3 - Fit Somatec turret

Step 4 - Fit the new strike plate

Step 5 - Fit new bolts into rotating head of turret

Step 6 - Test rotation and feedback from IO screen

Step 7 - Label the turret bolts and capstan positions

Comments

## Step 1 - Remove existing turret and associated parts

Remove all parts from the existing turret, to leave just the mounting plate and the cylinder and fittings etc, as shown

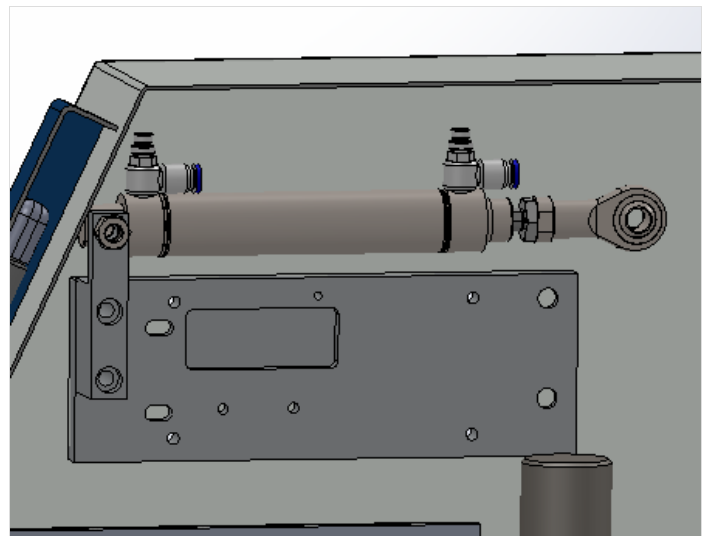

## Step 2 - Fit Sometec mount

Fit the Sometec mount block (D0015715) with M8 bolts (you will need to remove the mounting plate from the hood to bolt in from behind).

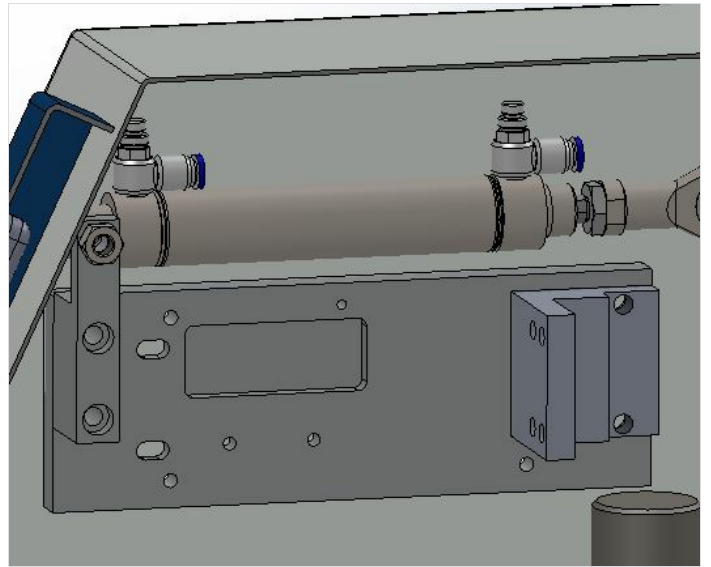

## Step 3 - Fit Sometec turret

Fit Sometec turret with 3 off M6 bolts.

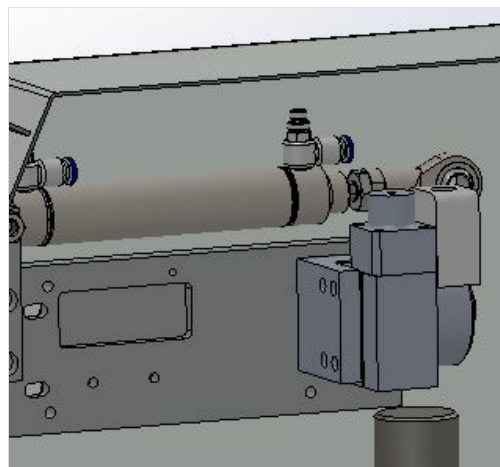

## Step 4 - Fit the new strike plate

Fit new strike plate. It has the same mounting points etc as existing one, so all fittings can be reused

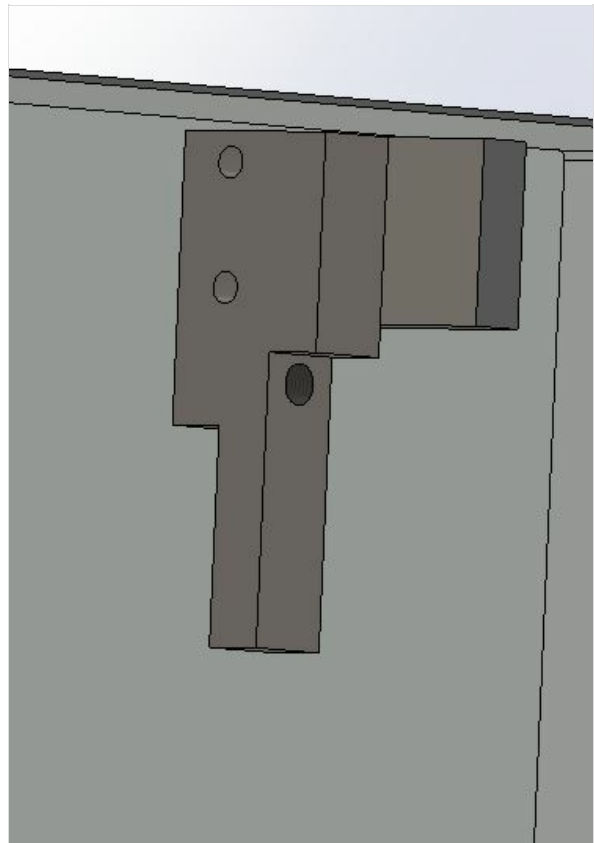

## Step 5 - Fit new bolts into rotating head of turret

Install bolts into the turret head, according to required length. Ensure that they strike on the strike plate.

---

## Step 6 - Test rotation and feedback from IO screen

The feedback should count up in binary for the position selected

Pos	ixA	ixB	ixC
1	1	0	0
2	0	1	0
3	1	1	0
4	0	0	1
5	1	0	1
6	0	1	1

---

## Step 7 - Label the turret bolts and capstan positions

Using the IO screen, rotate to position 1.

1. Using a pneumatic pipe marker, Label the "active" bolt with the number relating to the feedback position
2. Using a permanent marker, label the capstan where it is clearly visible

Repeat for all 6 positions

---