

# R0015270 Bench assemble Shafts, bearings and sprockets

instructions to check parts and prepare for fitting

 Difficulty **Medium**

 Duration **2 hour(s)**

## Contents

Introduction

Step 1 - Unless otherwise stated

Step 2 - Prepare shafts

Step 3 - Prepare bearings

Step 4 - Prepare Drive sprockets

Step 5 - Check fit of bearings on shafts

Step 6 - Check fit of sprockets on shafts

Step 7 - Grease bearings

Step 8 - Store prepared parts

Comments

## Introduction

### Tools Required

Emery tape 180 grit  
FE10 solvent  
Compressed air line  
Cleaning cloth  
Grease application gun

### Parts Required

D0015459B x 1  
D0015458B x 1  
B0001150 x 9  
B0001145 x 9

## Step 1 - Unless otherwise stated

Use loctite 243 on all fasteners

Use Loctite 572 on all threaded pneumatic connections

Pen mark all bolts to show finalised



## Step 2 - Prepare shafts

Check for any burrs or damage . If present remove with emery tape

Clean shafts D0015459B and D0015458B with fe10 solvent and compressed air to remove any debris or contamination

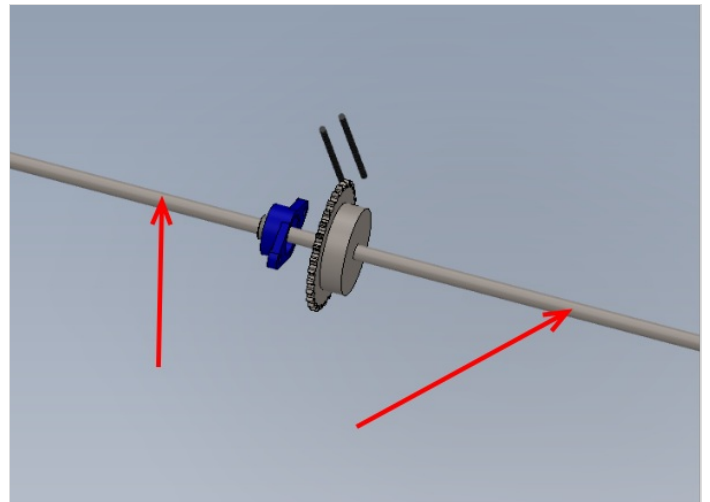

## Step 3 - Prepare bearings

Check for any internal burrs around tapped holes . If present remove with emery tape

Clean 9 off bearings B0001150 with fe10 solvent and compressed air to remove any debris or contamination

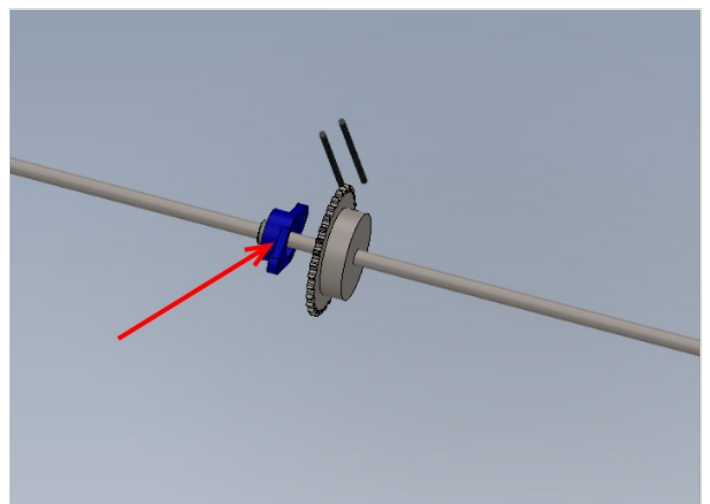

## Step 4 - Prepare Drive sprockets

Check for any internal burrs around tapped holes . If present remove with emery tape

Clean 9 off sprockets B0001145 with fe10 solvent and compressed air to remove any debris or contamination

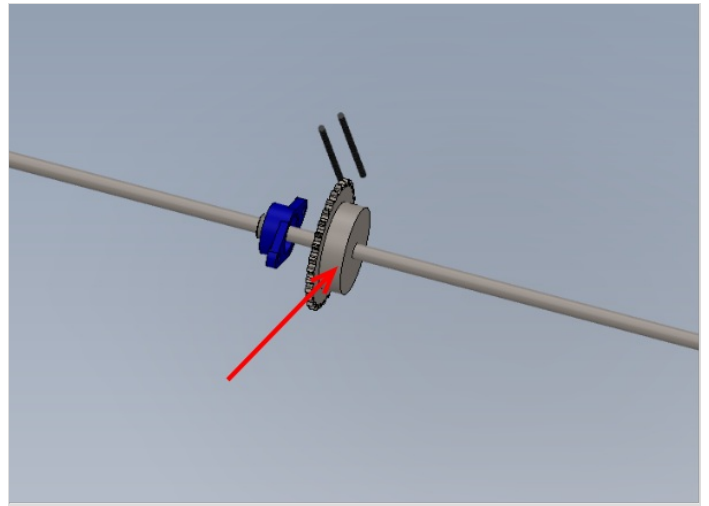

---

## Step 5 - Check fit of bearings on shafts

Check that all bearings slide easily along the entire length of both shafts .

Any tight spots should be dressed down with emery tape, cleaned and retried.

Repeat until all bearings pass freely along both shafts

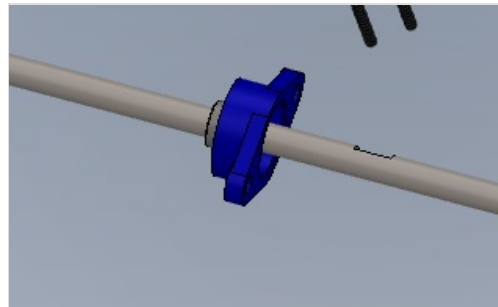

---

## Step 6 - Check fit of sprockets on shafts

Check that all sprockets slide easily along the entire length of both shafts .

Any tight spots should be dressed down with emery tape, cleaned and retried.

Repeat until all sprockets pass freely along both shafts

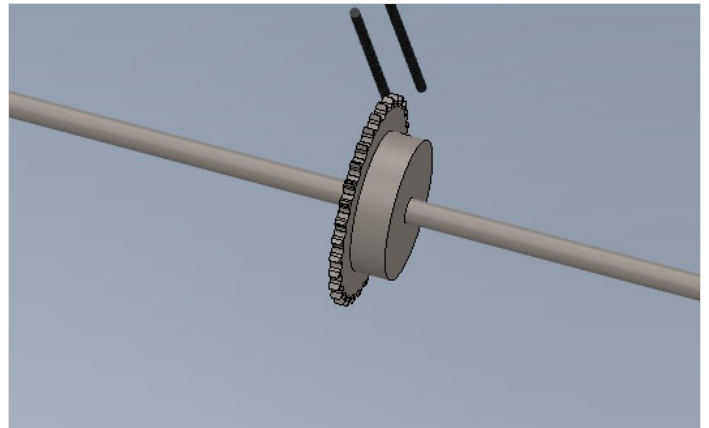

---

## Step 7 - Grease bearings

Spherical bearings should be greased with grease gun prior to fitting to ease spherical movement and aid installation

---

## Step 8 - Store prepared parts

Store prepared shafts, sprockets and bearings ready for next stage

---