

ITEM NO.	PART NUMBER	DESCRIPTION	QTY.
1	B0000184	Journal Cap Seal 34	4
2	B0000185	Double Row Long Stud Journal Eccentric	2
3	B0000186	Double Row Long Stud Journal Concentric	2
4	B0001102	Double Edge Spacer Slide with Beam 7600mm Long	1
5	C0001001	Gearbox LP+070 5:1 to suit AM3032 Motor	1
6	C0001122	Servo Motor: Beckhoff AM8032 2.1Nm 6000rpm	1
7	D0008301	Driver Gear	1
8	D0015072	Carriage Plate	1
9	D0015073B	Motor Adaptor Plate	1
10	D0015138	Energy Chain Tray Bracket Short	4
11	D0015139	Energy Chain Tray Bracket Long	4
12	D0015290	Beam End Stop	2
13	D0015492	Vertical Beam Adjustment Plate	5
14	D0015493	Lateral Beam Adjustment Plate	5
15	D0015598	Datum Flag: Saw Infeed	1
16	D0015717	Energy Chain Angle Bracket Lower	5
17	D0015718	Energy Chain Angle Bracket Upper	5
18	D0015720	Carriage Bracket	1
19	D0015721	Energy Chain Tray Deep Long	1
20	D0015723	Energy Chain Tray Shallow	1
21	D0015724	Energy Chain Tray Deep	1
22	D0015725	Energy Chain Tray Shallow Medium	1
23	E0000336	8mm Threaded Proximity Sensor	1
24	M0001077	Rubber Bump Stop M6	2
26	P0000238	Elbow Mini 1/8" - 6mm	2

ITEM NO.	PART NUMBER	DESCRIPTION	QTY.
27	P0001008	Regulator c/w pressure gauge 0 - 8.5 Bar	1
28	P0001022	Regulator Bracket: to suit P0001008	1

Note:
147 links of Energy Chain to be used

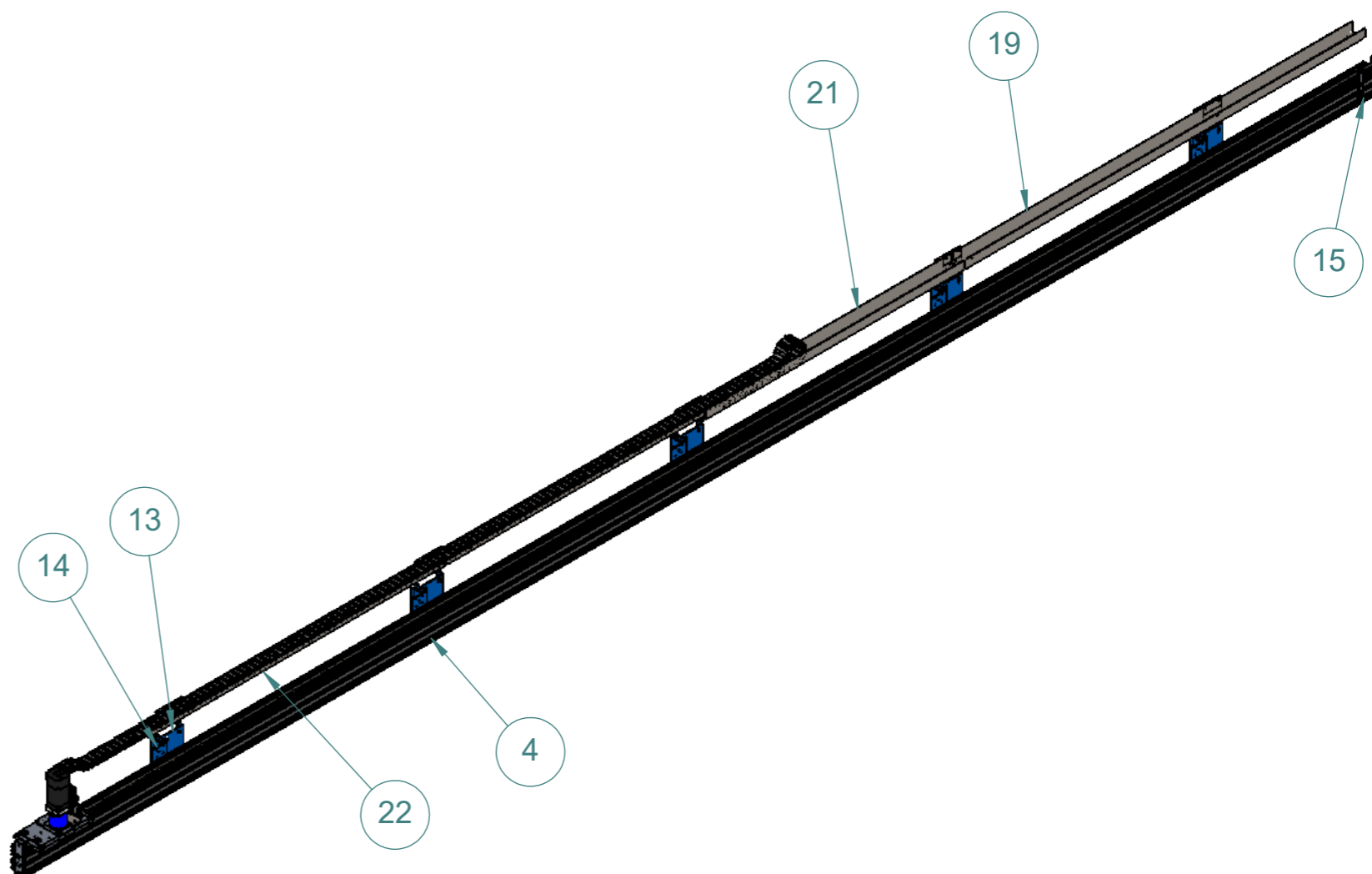

2	17/07/2020	MH	Additional note about Energy Chain length added	
1	16/06/2020			
Issue	Date	Drawn	Description of Change	ECR

Assembly Notes:

Stuga[®]

MACHINERY LTD

Stuga Machinery Ltd
4 Brinell Way
Harfreys Industrial Estate
Great Yarmouth,
NR31 0LU
Tel: 01493 742348
Web: www.stuga.co.uk

Drawing Title
**Saw Infeed X-Axis
Assembly ZX5 (2020)**

Scale
Unless
otherwise
stated

1:50

Drawn Date Chk'd Date
15/06/2020

Sheet
1 of 2



This drawing and the information there on is the property of Stuga Machinery Ltd. Drawings may not be sold, lent or copied without the prior consent of Stuga Machinery Ltd and must be returned on demand

Weight
92.51 kg

First Angle Projection
Dimensions in millimeters
unless otherwise stated
Do not scale, if in doubt ask

Drawing No.
R0015029C

Is
2

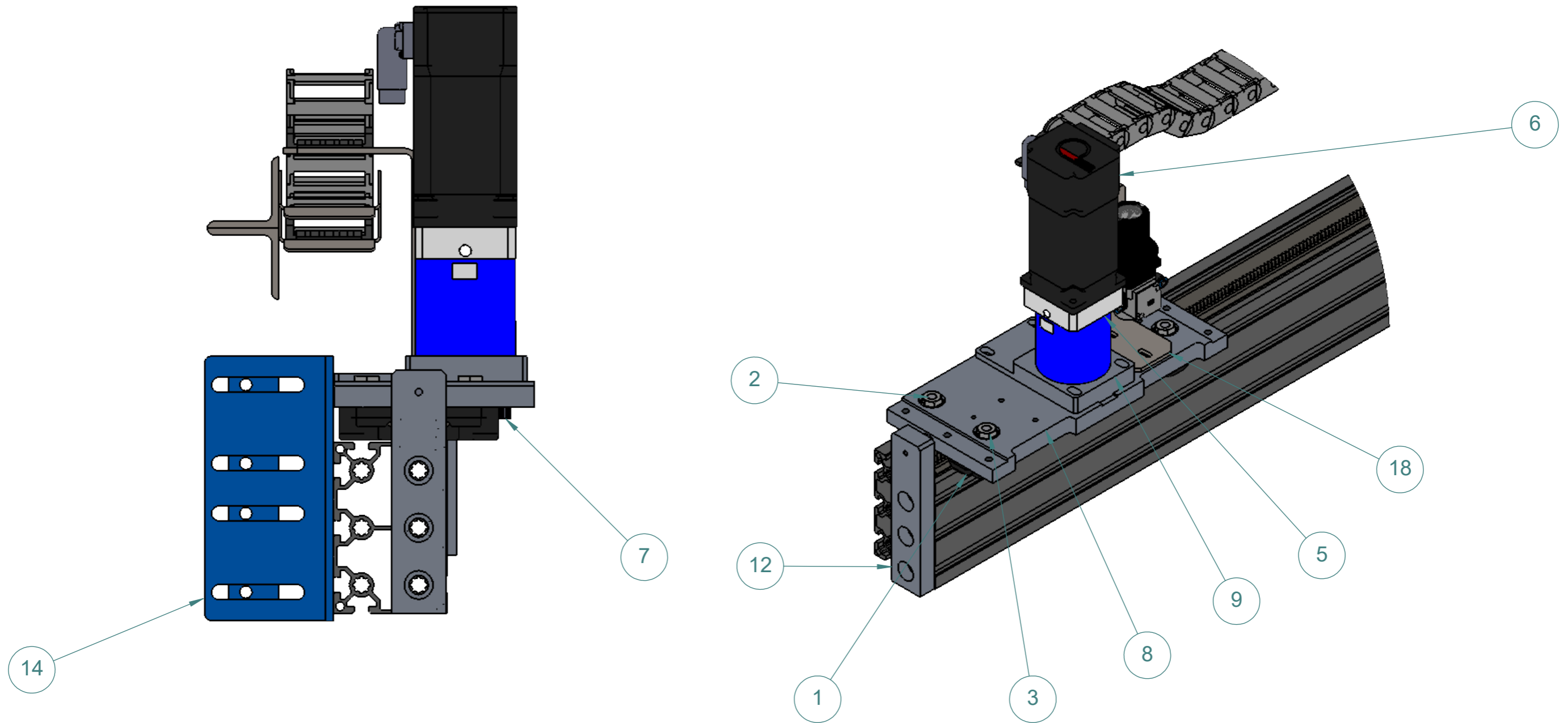

Assembly Notes:

Stuga[®]
MACHINERY LTD

Stuga Machinery Ltd
4 Brinell Way
Harfreys Industrial Estate
Great Yarmouth,
NR31 0LU
Tel: 01493 742348
Web: www.stuga.co.uk

Drawing Title				Scale Unless otherwise stated
Saw Infeed X-Axis Assembly ZX5 (2020)				1:50
Drawn	Date	Chk'd	Date	Sheet
	15/06/2020			2 of 2
Drawing No.			Iss	
R0015029C			2	

© This drawing and the information there on is the property of Stuga Machinery Ltd. Drawings may not be sold, lent or copied without the prior consent of Stuga Machinery Ltd and must be returned on demand

Weight
92.51 kg

First Angle Projection
Dimensions in millimeters
unless otherwise stated
Do not scale, if in doubt ask

A3